



ProtoLaser U4

User manual

Publisher LPKF Laser & Electronics AG
Osteriede 7
30827 Garbsen
Germany
Phone: +49 5131-7095-0
Fax: +49 5131-7095-90
Email: info@lpkf.com

Date of issue 2016-05-30

Copyright © 2016 LPKF AG

This document and its contents in whole and in parts are subject to copyright. The reproduction, translation or duplication of the contents as photocopy or any digital form requires written permission of LPKF Laser & Electronics AG.

Translation of the German original document

General information

This document contains all information for the intended use of the system/product delivered. This document is intended for persons with basic knowledge of installation and operation of software-controlled systems. General knowledge of operational safety as well as basic knowledge of using PCs running Microsoft Windows® are required.

- ▶ Read this document and possibly associated safety data sheets carefully before first start-up and usage of the components.
- ▶ Observe the safety regulations as well as the regulations on operational health and safety and protection of the environment.
- ▶ Use the system/product only in a technically perfect condition.
- ▶ Observe all labels and safety signs on the system/product.
- ▶ Never remove the safety signs and replace or clean them if not readable anymore.
- ▶ Persons who install, operate, uninstall, or maintain our systems/products must not be under the influence of alcohol, other drugs, or medication that impairs the ability to react.
- ▶ Use only approved spare parts and accessories in order to prevent injuries due to unsuitable spare parts and accessories.
- ▶ Observe the technical data and ambient conditions specified in this document.

Validity

This document is part of the system/product and corresponds to the technical state at the time of publication. This document has always to be present at the system/product and has to be available to the operating personnel without restrictions, in a complete and legible form and at all times. If the operator changes, this document has to be handed over together with the system/product. The operator has to ensure that all safety measures specified in this document are observed.

The operating personnel must have read and understood this document before performing any task. A basic requirement for safe work is observance of all safety notes and steps. This document contains important information about the system/product that have to be observed when installing, first starting up, or maintaining the system/product. Its structure allows trained personnel to perform all tasks.


LPKF Laser & Electronics AG (abbreviated to **LPKF** in the following) reserves the right to make changes in respect to the content of this document. The figures in this document serve as basic understanding and can differ from the actual state of the system.

Structure of warning messages and safety notes

The safety notes and warning messages in this document identify hazards and risks and they are created in accordance with ANSI Z535.6-2011 and the standards series ISO 3864.

The warning messages are structured as follows:


- Warning sign (only for injuries)
- Signal word indicating the hazard class
- Type and source of the hazard
- Consequences of non-observance
- Measures to avoid the hazard


 + SIGNAL WORD
<p>Type and source of the hazard! Consequences of non-observance.</p> <ul style="list-style-type: none"> ▶ Measures to avoid the hazard. ▶ Further measure(s) to avoid the hazard.

Warning messages can also be embedded in the format of the surrounding text in order to avoid a *visual disruption* in a sequence. In this case, they are distinguished as follows:

- Type and source of the hazard!**
- ▶ **Measure(s) to avoid the hazard.**

Warning messages are classified in hazard classes represented by the signal word. In the following, the warning messages are described in accordance to their hazard classes:

 DANGER
<p>Type and source of the hazard! This warning message indicates a hazard of high risk that causes death or serious injury if not avoided.</p> <ul style="list-style-type: none"> ▶ Measure to avoid the hazard.

 WARNING
<p>Type and source of the hazard! This warning message indicates a hazard of medium risk that can cause death or serious injury if not avoided.</p> <ul style="list-style-type: none"> ▶ Measure to avoid the hazard.

CAUTION

Type and source of the hazard!

This warning message indicates a hazard of low risk that can cause minor or moderate injury if not avoided.

- ▶ Measure to avoid the hazard.

NOTICE

Type and source of the hazard!

This warning message indicates a hazard that can lead to possible property damage.

- ▶ Measure to avoid the hazard.

Text styles

Various text attributes, notations, and text structures facilitate reading the document. The text attributes (highlightings) inside this document are defined as follows:

Attribute	Function
<i>italic</i>	highlights elements of the user interface and of control elements of the system
bold	highlights important information and keyboard input
Courier New	highlights file paths
[]	highlights elements of buttons on software user interfaces
key	highlights keys of the keyboard

Tasks or procedures that are described in steps are compiled to sequences in this document. A sequence consists of at least three components: objective, step, and result.

Component	Description
■	Indication of an objective. The sequence starts here.
1. 2. 3.	Indication of a sorted list of steps. The specified order must be observed.
□	Indication of an intermediate result that is followed by further steps or the result.
☑	Indication of the result. The sequence is finished.
▶	Indication of a single step.

Additional information

The following symbols are used to indicate additional information:



This note indicates especially useful information.

**Advanced information**

This advanced information indicates special knowledge.

Registered Trademarks

Product and brand names are trademarks of LPKF Laser & Electronics AG, registered among others at the US Patent and Trademark Office: LPKF[®] and the company logo, # 2,385,062 and # 2,374,780; Solarquipment[®], # 3,494,986; ProConduct[®], # 3,219,251; Allegro[®], # 3,514,950.

Microsoft[®] and Windows[®] are brand names or registered trademarks of Microsoft Corporation in the USA and/or other countries. All other trademarks belong to the respective owner.

Limited liability

All data, notes and instructions in this document have been prepared with consideration to the statutory standards and regulations, the present state of technology, as well as our many years of knowledge and experience.

LPKF accepts no liability for damage due to:

- non-observance of this document
- improper use of the system/product
- employment of personnel that is not sufficiently qualified
- unauthorized modification
- technical changes
- unauthorized manipulation of the safety devices
- use of spare parts that are not approved by LPKF

The actual scope of delivery can deviate from the explanations and presentations given here, due to custom designs, the utilization of additional order options, or due to the most recent technical changes.

The responsibilities agreed in the delivery contract, the General Terms and Conditions as well as the delivery conditions of the manufacturer and the statutory regulations valid at the time of the conclusion of the contract are effective.

Warranty

Please note that the warranty is subject to the current regulations in combination with the current General Terms and Conditions.

All information and instructions in this document have been compiled in observance of current regulations and the current state of the art. Before working with the system/product, this document has to be read carefully. The manufacturer assumes no liability for damage and faults due to non-observance of this document.

LPKF Laser & Electronics AG provides a 12-months warranty if the following conditions are met:

- The warranty starts on delivery.
- The warranty covers defects in material or manufacture. During the warranty period, such defects are remedied without cost by replacement or rework of the defective parts. This service is provided by the LPKF Service.

For further information on wear parts refer to the chapter scope of delivery.

Customer service

For technical information contact our LPKF Service:

Address LPKF Laser & Electronics AG
Service & Support Rapid Prototyping
Osteriede 7
30827 Garbsen
Germany

Phone + 49 5131 7095-1333

Fax + 49 5131 7095-90

Email support.rp@lpkf.com

Internet www.lpkf.com

In our continuous effort to improve our documentation we are asking you to give us your feedback if you notice any discrepancy when working with the system/product, or if you have any comments or suggestions for improvement.

At the moment of packaging, the system/product has been equipped with the latest software version and with the software and hardware documentation currently valid. By now, new versions of the documentation as well as new software versions might be available.

For all the latest news and updates visit the support area of our homepage:
<http://www.lpkf.com/support>.

Contents

1	Safety	11
1.1	Intended use	11
1.2	Residual risks.....	11
1.3	Basic hazards	12
1.4	Laser safety instructions	14
1.4.1	Laser radiation hazards.....	14
1.4.2	Laser classes	16
1.4.3	Protective measures	17
1.4.4	Actions in case of an injury	19
1.4.5	Laser Safety Instructions.....	19
1.5	Responsibility of the operator	20
1.6	Personnel requirements.....	21
1.7	Personal protective equipment	22
1.8	Safety signs	23
1.9	Safety devices.....	25
1.10	Securing against restart	28
1.11	Actions in case of an emergency.....	29
1.12	Environmental protection	29
2	Technical data	30
3	Structure and function	32
3.1	Brief description	32
3.2	Scope of delivery	32
3.3	Type label	34
3.4	System components	35
3.4.1	Total view	35
3.4.2	Laser source	36
3.4.3	x/y table.....	39
3.4.4	Extraction hood	39
3.5	Optional modules, accessories, extras	40
3.6	Connections	43
3.6.1	Connections of the extraction hood	44
3.6.2	Power meter connector	45
3.6.3	Pin assignment.....	45
3.7	Displays and control elements	46
3.8	Software.....	51
3.9	Modes of operation	53
4	Transport and storage	54
4.1	Transport inspection	54
4.2	Packaging	54
4.2.1	Symbols on the packaging	55
4.2.2	Unpacking the system.....	55
4.3	Transporting the system	60
4.3.1	Moving the system over short distances	60
4.3.2	Leveling the system	62
4.4	Storage.....	63
5	First startup	64
5.1	Safety	64
5.2	Requirements of the place of installation	64
5.2.1	Climatic conditions	65
5.2.2	Minimum required space.....	65

5.2.3	Workplace of the operating personnel	66
5.2.4	Floor	66
5.2.5	The system's center of gravity	67
5.2.6	Connections provided by the customer	67
5.3	Preparations	68
5.3.1	Removing the transport locks	69
5.3.2	Filling the coolant	73
5.3.3	Checking the local mains voltage of the chiller	75
5.4	Connecting the system	77
5.4.1	Connecting the stack light	77
5.4.2	Connecting the extraction system	79
5.4.3	Connecting the compressed-air supply	81
5.4.4	Connecting to the network	82
5.4.5	Connecting the screen, keyboard, and mouse	83
5.4.6	Connecting the system to the mains power supply	86
5.4.7	Switching on the system with the main switch	87
6	Operating the system	88
6.1	Safety	88
6.1.1	Switching off the system in an emergency	88
6.1.2	Restarting the system after an emergency stop	89
6.2	Preparations for use	89
6.3	Typical production process	90
6.4	Special tasks	102
7	Maintenance	103
7.1	Safety	103
7.2	Maintenance schedules	104
7.2.1	Maintenance schedule for the maintenance personnel of the operator	104
7.2.2	Maintenance schedule for the LPKF Service	105
7.3	Maintenance tasks for the maintenance personnel of the operator	105
8	Troubleshooting	122
8.1	Fault display	122
8.2	Actions in case of an error	123
8.3	Fault table	123
8.4	Processing quality	126
9	Disassembly and disposal	127
9.1	Safety	127
9.2	Preparations	127
9.3	Disposing of the system	127
10	Appendix	128
10.1	List of figures	128
10.2	List of tables	130
10.3	Index	131
10.4	EC Declaration of conformity	132

1 Safety

This chapter provides an overview of all important safety aspects for protecting persons as well as for a safe and fault-free operation of the system/product. There are further warning messages in the sections of the individual lifecycle stages.

1.1 Intended use

The system is especially developed for micro material processing and approved for the following processing procedures and materials

Processing procedures

- Structuring laminated substrates
- Separating rigid, flex-rigid, and flexible materials
- Drilling and separating ceramics
- Structuring TCO/ITO
- Cutting LTCC



In case of doubt contact the LPKF sales department or your local representative to receive more information on alternative materials or processing procedures.

Only control the system with the system software that is included in the scope of delivery.

The system may only be operated with an extraction system that is sufficiently dimensioned.



Contact the LPKF sales department or your local representative if you plan to use another extraction system.

Only use qualified and approved extraction systems.

Any other kind of use is considered as not intended. The manufacturer is not liable for any damage resulting from this, the operator alone bears the risk. Part of the intended use is also to follow the instructions for safety in this user manual with regard to operation and maintenance of the system.

Improper use

Do not use the system for processing easily flammable materials (e.g. paper, wood, etc.).

Using the system without the standard cover and covering parts is not allowed. The system must not be used with a different or modified system software.

1.2 Residual risks

No residual risks have currently been identified, if the intended use as well as all safety regulations are observed. Any identified residual risks and their avoidance are listed in the form of safety instructions starting in chapter 1.3. Non-observance can cause personal injuries and property damage.

1.3 Basic hazards

Always comply with the warning messages listed here and in the individual sections of this documentation to reduce the risks of injuries and property damage and to avoid dangerous situations.

Mechanical hazards

WARNING

Risk of injury by moving components!

Moving components can cause serious injuries e.g. crushing injuries or cuts.

- ▶ Never grasp moving components when the system is operating.
- ▶ Never open any covers when the system is operating.
- ▶ Observe the follow-up time. Before opening the cover, ensure that no component is still moving.

WARNING

Risk of injury by loss of stability!

Loss of stability due to an improper floor or missing locks can cause uncontrollable movement or tilting of the system. This can cause serious injuries.

- ▶ Ensure that the floor is even and has a sufficient load-bearing capacity.
- ▶ Secure the system properly so that it cannot roll away unintentionally.

WARNING

Risk of injuries by pressurized components!

Pressurized components (e.g. compressed-air supply) can move uncontrollably in case of improper handling or in case of a defect and can cause serious injuries.

- ▶ Depressurize the components before working on them. De-energize the residual energies.
- ▶ Always ensure that there is no unintended escape of compressed air.
- ▶ Defective components that are under pressure when operating the system have to be replaced immediately by sufficiently qualified personnel.

Electrical hazards **DANGER****Danger to life by electrical shock!**

Touching energized parts causes a direct danger to life by electrical shock. Damage to the insulation or damaged individual parts can be dangerous to life.

- ▶ All work on energized components of the system must be performed by a qualified electrician.
- ▶ If the insulation is damaged, switch off the power supply immediately and initiate the repair.
- ▶ De-energize all energized components of the system or equipment, before working with them. Ensure that the system or equipment is de-energized for the whole time of the task.
- ▶ Never bridge or deactivate fuses.
- ▶ Always keep moisture away from energized parts because it can cause a short circuit.

Hazards by materials or substances **WARNING****Health hazard by faulty extraction!**

When processing materials, gases or dusts hazardous to health can be produced.

- ▶ Ensure that the extraction system is switched on and is working properly.
- ▶ Observe the maintenance intervals of the extraction system.
- ▶ Check the connection to the system regularly.

1.4 Laser safety instructions

This chapter contains basic information on protection against the hazards of laser radiation. Every user of this laser system must read and understand this chapter before he/she is authorized to work with the system. An annual laser safety instruction delivered by the laser protection officer of the company is required.

1.4.1 Laser radiation hazards

The laser light is very orderly and regular in terms of propagation direction and wavelength. Laser light has a high energy and can travel over wide distances with an almost parallel propagation. The laser power is not dependent on the distance to the target.

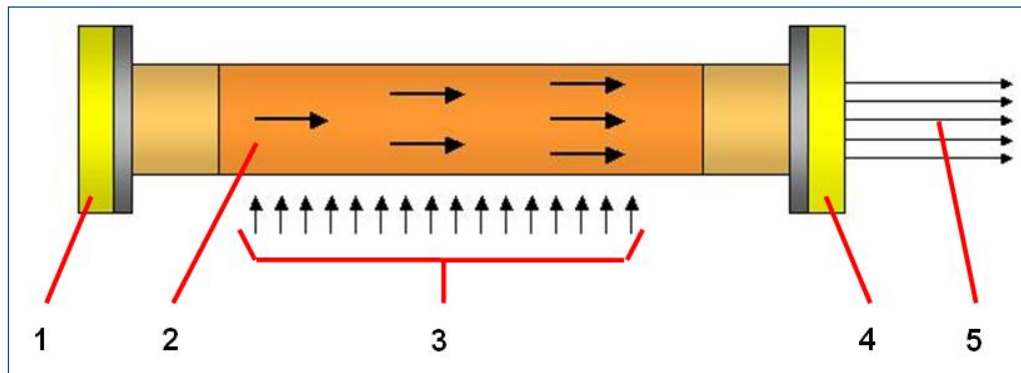


Fig. 1: Functional principle of a laser

- | | |
|-----------------------------|----------------------------|
| 1 Mirror (fully reflective) | 4 Mirror (semitransparent) |
| 2 Laser medium | 5 Laser beam |
| 3 Pump energy | |

Effects on the human eye

In addition to the high energy and the power density, the high focusability of the coherent laser beam is another danger to the human eye. A laser pulse hitting the visual nerve of the eye can cause blindness.

Effects on the human skin

The extent of damage to the human skin is highly related to the wavelength of the laser beam so that the damage can vary between light sunburn, heavy blistering and carbonization of the skin. The impact also depends on the laser power and the duration of irradiation.

Thermal damage

Thermal tissue damage can be classified into reversible and irreversible physical injuries. Reversible tissue injuries are caused by temperatures below 45 °C. Tissue dies off (protein coagulation) due to thermal damage at temperatures between 45 °C and 80 °C. The water inside the tissue is vaporized at temperatures above 100 °C. At temperatures above 150 °C the tissue is carbonized. At temperatures above 300 °C the tissue is evaporated.

Damage depending on laser beam wavelength

Wavelength (nm)		Spectral range	Eye	Skin
From	To			
180	280	UV-C	Keratitis	Sunburn
280	315	UV-B	Keratitis	Increased pigmentary abnormality
315	400	UV-A	Cataract	Tanning
400	780	Daylight	Retina damage	Burns
780	1400	IR-A	Retina damage, blindness	Burns
1400	3000	IR-B	Cataract or burns of the cornea	Burns
3000	106	IR-C	Burns of the cornea or corneal abrasion	Burns

Table 1: Effects of laser radiation**Other laser radiation hazards**

A laser system poses primary and secondary hazards. The primary hazards are due to the laser beam itself. The secondary hazards arise from the laser system or the processing procedure .

Source of danger	Description
Optics	If the laser system optics are broken, overheated or destroyed by other effects, the materials or the coatings can release hazardous particles and gases.
Pilot laser	The pilot laser is a compact laser diode or a class 2 HeNe laser. Do not expose your eyes to radiation unnecessarily. The laser radiation is harmless for the skin.
Laser gas	In excimer laser systems, the toxic and corrosive chemical substances such as chlorine and fluorine are a great health hazard. Thus, the workplace must be well ventilated at all times. Ensure that the gas cylinders are stored upright.
UV radiation	Metal vapor plasma is generated during the processing procedure of metals. This plasma is inducing UV light radiation. This UV radiation is hazardous to human eye and skin. This health hazard is particularly high during the welding processes.

Table 2: Sources of danger

1.4.2 Laser classes

The hazard levels of laser systems are based on the accessible emission limits (AEL) and listed in European Standard EN 60825-1 and the American National Standards ANSI Z136.1 for the Safe Use of Lasers.

Class	Concept	Safety measures
1	The radiation emitted by this laser system is not dangerous.	No specific protective equipment is required.
1M	The radiation emitted by the laser system is eye safe when used without optical instruments. The emitted radiation is not safe when optical instruments are used.	No specific protective equipment is required if the laser system is used without optical instruments.
1C	These laser systems are used for medical purposes only. The radiation emitted by the laser system is not subject to any limitations.	The protection is ensured by technical measures so that the laser can only emit a beam while having contact to skin or tissue. For this, the radiation is reduced to class 1.
2	The laser system is eye safe as a result of normal human aversion responses including the blink reflex.	No specific protective equipment is required.
2M	The light that can penetrate the eye pupil has the value of a class 2 laser. Depending on a divergent or widened beam, it may not be safe when optical instruments are used.	No specific protective equipment is required if the laser system is used without optical instruments.
3R	Exceeds the maximum permissible exposure values. The radiation is max. 5 times higher than the AELs of class 1 or of class 2. The risk is slightly lower than the risk of class 3B.	Dangerous to the human eye, laser protective glasses are recommended.
3B	Looking into the laser beam is dangerous to the eyes. Diffuse reflections are not considered as dangerous. (former class 3 B without class 3 R)	Dangerous to the human eye, laser protective glasses are obligatory.
4	Even diffuse reflections are dangerous to the human eye. There is also a danger of fire and danger to the human skin.	Personal protective equipment is absolutely necessary (laser protective glasses and protective screens)!

Table 3: Laser classes

1.4.3 Protective measures

The operator of a laser system is obliged to take structural and organizational protective measures.

Personal protective measures

The operating personnel must comply with certain protective measures when working on a laser system.

Protective measures	1	1M	1C	2	2M	3R	3B	4
Never look directly into the laser beam neither with nor without laser protective glasses.	x	x	x	x	x	x	x	x
Wear laser protective glasses						x	x	x
Attend a laser safety instruction course once a year							x	x

Table 4: Personal protective measures

Structural protective measures

Depending on the laser class, special protective measures must be taken or be existent.

Protective measures	1	1M	1C	2	2M	3R	3B	4
Walls, ceilings and floors must be built solid and fire proofed. The wall areas must be matte, bright and diffusely reflecting.							x	x
Non-metallic (non-reflecting) installations							x	x
Ambient light must be amply dimensioned and adjustable							x	x
Adequate number of emergency stop buttons, room and door contact switches							x	x
Shielding: high absorption, hardly inflammable							x	x
Specular reflection: avoid any unintended reflections						x	x	x
The laser beam must be limited at the end of its useful path		x	x	x	x	x	x	x
Label the laser area (Warning laser beam) inside the working and traffic area				x	x			
Restrict access to the laser area and label the borders (Warning laser beam)						x	x	x
Operation mode displays and warning lights on all entrance doors of the laser area								x

Table 5: Structural protective measures

Organizational protective measures

Depending on the laser class, special protective measures must be taken.

Protective measures	1	1M	2	2M	3R	3B	4
Inform the Employer's Liability Insurance Association and the industry control office.					x	x	x
A laser safety officer must be appointed in written form.					x	x	x
The borders of the laser area must be defined if the laser area is inside working or traffic areas.			x	x			
The borders of the laser area must be defined.					x	x	x
A remote-controllable locking device must be connected to the room or door electric system.						x	x
The laser system must be equipped with a key switch to securely switch-off the system (key removed).						x	x
The operating personnel must wear laser protective glasses acc. to EN 207.					x	x	x
The operating personnel must wear laser adjustment glasses compliant to EN 208 during adjustment tasks.					x	x	x
The operating personnel must wear protective clothes if necessary (for example protective gloves).					x	x	x
The operating personnel of the laser system must attend a laser safety instruction course.		x	x	x	x	x	x
All insured persons inside the laser area must attend a laser safety instruction course.					x	x	x
Adolescents under 16 years of age are not allowed to enter the laser area. Adolescents between 16 and 18 years of age are only admitted to the laser area if it is instrumental to achieving the educational objective.					x	x	x
Immediate medical care in case of any suspected eye injury.	x	x	x	x	x	x	x

Table 6: Organizational protective measures

1.4.4 Actions in case of an injury

In case of injury or only suspected injury, proceed as follows:

- ▶ The injured person has to consult a dermatologist or eye specialist immediately. Always have the eye fundus examined.
- ▶ Switch off the laser system and secure it against restart.
- ▶ Describe the accident details in a report.
- ▶ Inform the laser protection officer.
- ▶ Inform the supervisor.

1.4.5 Laser Safety Instructions

Observe strictly the following safety instructions for working with laser systems:

- ▶ Only the persons whose presence is required should be present in the laser area.
- ▶ The laser radiation of systems of laser classes 1C, 2, 2M, 3A, 3B and 4 should reach only as far as required for the specific application.
- ▶ Avoid any random reflections when using lasers of class 3 or 4. Keep away, remove or cover any reflecting/glossy objects or surfaces near the laser beam.
- ▶ Any person present in the laser area must be informed immediately when a laser system of class 3 or 4 will be switched on.
- ▶ A laser system is only safe, when no uncontrolled reflected radiation is emitted and access to the laser beam is prevented during operation.
- ▶ Looking directly into the laser beam is forbidden. Even proper laser protective glasses provide only limited protection against direct, specularly reflected or diffusely scattered laser radiation.
- ▶ Use only laser protective glasses that are approved for the specific laser system and are able to absorb the wavelength used.
- ▶ Check the laser protective glasses before every usage. Only undamaged and approved protective glasses (for wavelength and laser class) must be used.
- ▶ Inform the laser protection officer immediately about any damage of the laser system like changes on the protection filter, for example glass cracks, change in color, change in transparency and defects of the carrier.
- ▶ Do not wear any jewelry or other glossy or reflecting objects when operating a laser system.
- ▶ A laser system that is completely shielded with a protective housing is equivalent to laser class 1. If the protective housing is removed, the laser class is increased.

1.5 Responsibility of the operator

Operator

The operator is the person/company who operates the system/product themselves for industrial or commercial purposes, or makes it available to a third party for use and has the product responsibility for the safety of the system operator/user, the personnel in general, and other persons present.

Operator's obligations

The system/product is used in the industrial sector. The operator of the system/product is thus subject to the statutory obligations for occupational health and safety.

In addition to the safety instructions in this document, the safety, accident prevention, and environmental protection regulations must also be observed at the system's/product's place of operation.

The following applies in particular:

- The operator must inform himself about the effective industrial safety regulations and determine additional hazards in a risk assessment that result from the special working conditions at the system's/product's place of operation. The operator has to implement these in the form of operating procedures for the operation of the system/product.
- During the total operating life of the system/product, the operator has to check and ensure that the established operating procedures comply with the current state of the rules and standards and adapt them, if necessary.
- The operator has to define clear-cut responsibilities for installation, operation, trouble-shooting, maintenance, and cleaning.
- The operator has to make sure that all persons who are working with the system/product have read and understood this document. Furthermore, the personnel has to be trained and informed about the dangers on a regular basis.
- The operator has to provide the required personal protective equipment and instruct the personnel to wear it.
- The operator has to instruct the personnel to maintain a clean and tidy workplace. Eating and drinking at the workplace and especially while operating the system/product must not be permitted.

The operator is also responsible to keep the system/product in good working order. Thus, the following applies:

- The operator has to ensure that the maintenance intervals stated in this document are observed.
- The operator has to check all safety devices for proper function and completeness on a regular basis.

1.6 Personnel requirements

WARNING

Accident hazard due to insufficiently qualified personnel!

Insufficiently qualified personnel cannot assess the risks of using the system/product and put themselves and others in danger.

- ▶ Allow only qualified personnel to use the system/product.
- ▶ Keep insufficiently qualified personnel out of the working area.

The different tasks described in this document require different qualifications of the persons who are to perform these tasks.

If no personnel qualifications are listed in the individual chapters of this document, the operating personnel is intended to perform the tasks.

Only persons who can be expected to perform the tasks reliably are authorized to perform the tasks. Persons whose ability to react is impaired e.g. by drugs, alcohol, or medicine, are not authorized.

This document uses the following qualifications for persons for the different tasks.

Qualified electrician

A qualified electrician is able to perform work on electrical systems and to detect and avoid possible dangers on his/her own based on his/her professional training, know-how and experience as well as knowledge of the applicable standards and regulations.

The qualified electrician has been trained for the special field where he/she works and knows the relevant standards and regulations.

Maintenance personnel of the operator

Maintenance personnel are those persons who are designated by the operator to perform simple maintenance tasks (e.g. cleaning the system/product, removing parts from the system/product). The operator has to ensure that the personnel is suited for performing the work.

The maintenance personnel is able to perform his/her work and to detect and avoid possible dangers on his/her own based on his/her professional training, know-how and experience as well as knowledge of the applicable standards and regulations.

The maintenance personnel has been trained for the special field where he/she works and knows the relevant standards and regulations.

Service personnel

Service personnel are persons who are authorized by the manufacturer LPKF for servicing the system/product. These tasks may only be performed by the LPKF Service.

Operating personnel

Operating personnel trained by the operator is able to perform his/her work and to detect and avoid possible dangers on his/her own based on the training performed by the operator, his/her professional training, and his/her know-how and experience.

The operating personnel has been trained by the operator for the special field where he/she works and knows the relevant standards and regulations.

1.7 Personal protective equipment

Personal protective equipment protects against health or safety risks when working with the system.

The individual sections of this manual each point out the personal protective equipment (PPE) that has to be worn during the different tasks of working on the system.

This system is classified as laser class 1 if the cover is closed and it is not necessary to wear laser safety specific PPE during normal operation. If the cover is open (service mode), the system is classified as laser class 4.

Protective equipment for startup and maintenance tasks

- Laser safety glasses with a rating of LB3 for 355 nm
- Respirator half mask according to EN 141/143; protection level P3
- Safety shoes protection class 1
- Protective gloves
- Protective goggles
- Latex lab gloves

Personal protective equipment for working with hazardous substances and chemicals

- Respirator mask with gas filter for organic gases/vapors (boiling point > 65 °C, e.g. EN 14387 type A)
- Safety glasses with side shields (e.g. EN166)
- Chemical-resistant gloves, protection index 6 nitrile rubber (NBR) - 0.4 mm thickness

► Always read the safety data sheets before working with hazardous substances and chemicals and always observe the instructions given therein.

Description of the personal protective equipment



Laser protective glasses

Laser protective glasses protect the eyes against laser radiation for the specified wavelength(s) in the ultraviolet, visible, and infrared spectral range for at least 10 seconds or, in case of pulsed lasers, for at least 100 pulses.



Protective glasses with side shields

The protective glasses with side shields serve for eye protection in case of flying debris and liquid splashes.



Respirator mask

Respirator masks protect against hazards from harmful substances in gases, vapors, and particles.



Safety shoes

Safety shoes protect the feet against crushing injuries, falling objects and from slipping on slippery surfaces.



Protective gloves

Protective gloves protect the hands against friction, abrasions, puncture hazards and deep cuts as well as when touching hot surfaces.

1.8 Safety signs

This chapter lists the safety signs/pictograms that are applied to the system and describes their meaning.

WARNING	
<p>Risk of injury by nonobservance of safety signs!</p> <p>The safety signs on the system instruct you on safe usage of the system. Nonobservance of the safety signs can cause severe injuries.</p> <ul style="list-style-type: none"> ▶ Always observe the safety signs. ▶ Never remove the safety signs. ▶ Stick the safety signs in the language of your country on top of the corresponding safety signs applied on the system. ▶ Apply additional safety signs in the language used in your factory. ▶ If a safety sign is no longer legible, clean or replace the safety sign. 	

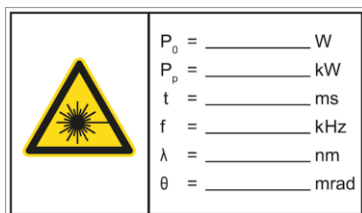


Classification of the laser system acc. to DIN EN 60825-1

This laser system is classified as class 1. The accessible laser radiation is not dangerous.

The label is applied at the following position(s):

- at the cover



Warning against artificial optical radiation!

Use your personal protective equipment to avoid damage to health.

The label is applied at the following position(s):

- on the system rear next to the main switch



Warning against visible and invisible radiation in case of bypassed safety devices in service mode!
 Use your personal protective equipment to avoid damage to health. The laser safety sign is marked with a **2** in the **lower right corner** for better identification.



The label is applied at the following position(s):

- at the cover



Warning against laser radiation from the laser output aperture!
 In order to avoid serious injuries to your skin or your eyes always comply with the safety instructions while operating the lasers.

The label is applied at the following position(s):

- on the front of the processing head

1.9 Safety devices

This chapter describes the safety devices of the system and how they work.

All system components are connected to the main earthing busbar in the system. The system is connected to the ground potential via the earth wire of the power supply cable.

DANGER

Danger to life by missing safety devices!

Missing or deactivated safety devices when working with the system cause serious or even fatal injuries.

- ▶ Always ensure that all safety devices are functioning properly and are switched on.
- ▶ Ensure that the safety devices are not bridged or manipulated in any other way.

WARNING

Danger to life by uncontrolled restart!

An uncontrolled restart of the system can cause serious injuries or even death.

- ▶ Before restarting the system, ensure that the reason for the emergency stop is eliminated and all safety devices are working properly.
- ▶ Only turn the main switch back to "I" or "ON" if there is no danger anymore.

CAUTION

Risk of injuries by external components!

If you use the main switch ("0" or "OFF") to switch off the system, only the electrical power supply of the system is disconnected. The supply of the external components (e.g. compressed air, extraction system) is still connected and can cause injuries.

- ▶ Disconnect the supply of all external components immediately.
- ▶ Before working with pressurized components, ensure that these are completely depressurized and de-energized.

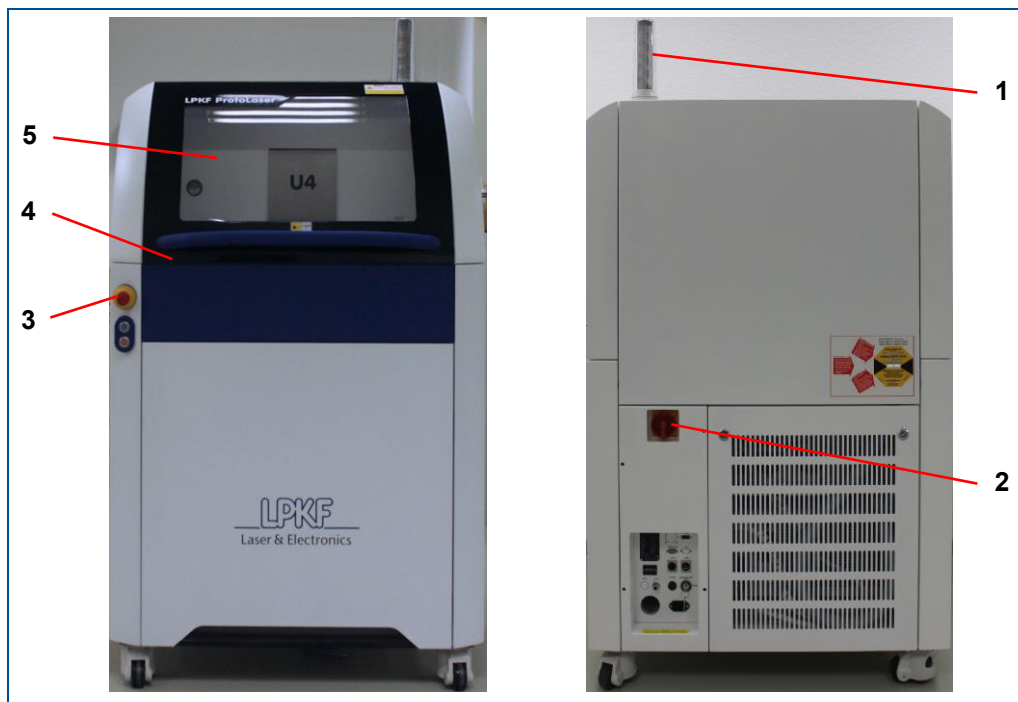


Fig. 2: System with safety devices

- 1 Stack light
- 2 Main switch
- 3 Emergency stop button
- 4 Magnet switch of the cover
- 5 Cover with laser protective pane



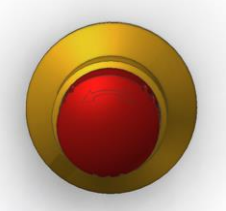
Figure	Description
	<p>The stack light (1) indicates the system's operating state. The following operating states are displayed with the stack light:</p> <p>Green: Ready for operation The system is ready for operation or already in operation. No fault is present.</p> <p>Orange: Service mode activated Laser class 4 is possible because safety devices have been shut off.</p> <p>Red: Fault Work cannot be continued until the fault is successfully reset by the user in the fault monitor.</p> <p>Blinking red The emergency stop button has been pushed.</p>
	<p>The main switch (2) at the rear of the system switches off or on the mains power supply. But it does not start the system yet. The main switch can be secured against restart with a padlock.</p>
	<p>The emergency stop button (3) is located at the front of the system. Pushing this button immediately switches off the laser and stops the motorized axis. This stop is only intended for an emergency.</p>



Figure	Description
	The magnet switch (4) protects against opening the cover while the system is in operation. If the cover is opened while the system is operating, the safety circuit is interrupted and the laser is disconnected from the power supply.
	The laser protective pane (5) protects against laser radiation.

Table 7: Safety devices

Maximum service life of safety-relevant components

Component	Service life in years
Safety relay cover monitoring	8
Laser safety shutter	5
Safety control unit (emergency stop button)	20
Magnet switch of cover	20

Table 8: Service life

1.10 Securing against restart

The system can be secured with a padlock at the main switch. The padlock is not included in the delivery.

WARNING

Danger to life by uncontrolled restart!

An uncontrolled restart of the system can cause serious injuries or even death.

- ▶ Before restarting the system, ensure that the reason for the emergency stop is eliminated and all safety devices are working properly.
- ▶ Only turn the main switch back to "I" or "ON" if there is no danger anymore.

■ Securing against restart

1. Turn the main switch to **0** or **OFF** to disconnect the system from the power supply.
2. Disconnect the supply of all external components.
3. Secure the main switch with a padlock.

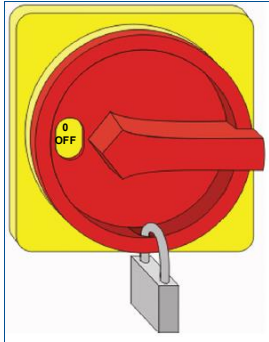


Fig. 3: Securing against restart

4. Keep the key safe.
- The system has been secured against restart.

1.11 Actions in case of an emergency

Preventive measures

- Always be prepared for fire and accidents!
- Keep first aid equipment (first aid kit, blankets etc.) and fire extinguishers in good working order and accessible at all times.
- Familiarize the personnel with accident reporting, first aid and rescue equipment.
- Keep access routes clear for rescue vehicles.

Actions in case of fire and accidents

- Use the emergency stop immediately to stop the system.
- Turn the main switch to 0 (OFF).
- Disconnect the supply of external components as soon as possible.
- If there is no risk for your own health rescue people from the danger zone.

Actions in case of a laser accident

- The injured person has to consult a dermatologist or eye specialist immediately. Always have the eye fundus examined.
- Switch off the laser system and secure the laser system against restart.
- Describe the accident details in a report.
- Inform the laser protection officer.
- Inform the supervisor.

1.12 Environmental protection

NOTICE

Environmental hazard by improper handling of substances!

Improper handling of environmentally hazardous substances, especially improper disposal, can cause considerable damage to the environment.

- ▶ Take appropriate measures immediately if environmentally hazardous substances are accidentally discharged into the environment. If you are in doubt, inform the appropriate local authorities about the damage and ask for appropriate measures that have to be taken.

The following environmentally hazardous substances are used:

Lubricants

Lubricants, such as greases and oils, contain toxic substances. They must not be released into the environment. They have to be disposed of by a waste management company.

Cleaning agents

Solvent-containing cleaning agents contain toxic substances. They must not be released into the environment. They have to be disposed of by a waste management company.

Coolant additive Glysantin

Has to be disposed of according to local regulations, e.g. at a suitable disposal site or a suitable incineration plant.

2 Technical data

General

Data	Value	Unit
IP Code (IEC 60529)	20	–
Service life	10	Years

Climatic conditions

Data	Value	Unit
Temperature range (operation)	22 ± 2	°C
Temperature range (storage, transport)	10 to 40, 0 to 50	°C
Max. humidity, non-condensing	< 60	%

Electrical data

Data	Value	Unit
Power supply	110/230	V
	50/60	Hz
Power rating	~1.4	kW
Leakage current	~2.15	mA

Mechanical data

Data	Value	Unit
Dimensions (width x height x depth)	910 x 1650 x 795 (35.8 x 65.0 x 31.3) (height with opened cover 1765 (69.5))	mm (in)
Weight (without packaging)	350	kg
Weight (with packaging)	390	kg

Load capacity

Data	Value	Unit
Min. distributed load	5.1	kN/m ²
Min. point load on an area of 0.00196 m ²	0.835	kN

Pneumatic data

Data	Value	Unit
Pressure	8	bar
Flow rate	450	NI/min

Compressed-air purity acc. to ISO 8573-1:2010-04

Data	Value	Unit
Solid particles	1	Class
Water	4	Class
Oil	1	Class

Laser data

Data	Value	Unit
Laser type	Nd:YVO4	–
Laser class (EN 60825-1:2008)	1 (production mode)	Class
	4 (service mode)	Class
Laser power	5.7 (50 kHz)	W
Laser wavelength	355	nm
Laser pulse frequency	25 to 300	kHz
Positioning accuracy	± 20	µm
Focused laser beam (diameter)	20 ± 2	µm
Repeatability	± 2	µm
Resolution	1.2	µm

Process data

Data	Value	Unit
Max. structuring area (x/y/z)	229 x 305 x 10 (9 x 12 x 0.4) 229 x 305 x 7 (9 x 12 x 0.28) (laminated substrates)	mm (in)
Max. material size (x/y/z)	239 x 315 x 7 (9.4 x 12.4 x 0.28)	mm (in)
Mark speed	5.5 (0.0085)	cm ² /min (sq in/min)
Base plate of the processing table (x/y)	268 x 344 (10.6 x 13.5)	mm (in)
z movement range of the processing table	11 (0.43)	mm (in)
Accuracy of laser scan area (calibrated)	± 10 (0.39)	µm (mil)

Emissions

Data	Value	Unit
Sound pressure level LpA (EN ISO 3744)	< 70	dB (A)
Sound power level LwA (EN ISO 3744)	< 70	dB (A)
EMC emission class	A	–

3 Structure and function

This chapter describes the technical structure and the functions of the system.

3.1 Brief description

The system structures and depanels various circuit board materials with the integrated laser source. The laser source produces ultraviolet radiation with a wavelength of 355 nm.

The system consists of five essential functional units:

- Laser source
- Chiller
- Beam deflection system with lens
- x/y table
- Camera system

3.2 Scope of delivery

This chapter provides an overview of the system's scope of delivery. For information on optional modules, accessories and extras refer to chapter Optional modules, accessories, extras starting on page 40.

ProtoLaser U4

- 2 x Control cabinet keys
- 1 x Screen with mains cable
- 1 x Keyboard
- 1 x Mouse
- 1 x Mains cable 230 V
- 1 x Mains cable 115 V
- 1 x Connection cable for extraction system
- 1 x DisplayPort cable
- 1 x USB cable
- 1 x Stack light
- 1 x Compressed-air tube
- 1 x Plastic container
- 1 x Coolant additive Glysantin
- 1 x Filter kit zero air filter
- 1 x Data medium Documentation
- 1 x Data medium CircuitPro PL
- 1 x Starter kit ProtoLaser
- 1 x Logbook

Data medium Documentation

The data medium contains the following:

- Brochure ProtoLaser U4
- User manual ProtoLaser U4
- Basic reference ProtoLaser U4
- Product catalog Rapid Prototyping

Data medium CircuitPro PL

The data medium contains the following:

- System software CircuitPro PL
- Product catalog Rapid Prototyping

Starter kit ProtoLaser (order code: SET-10-1128)

The starter kit contains the following:

Description	Quantity
Lens-cleaning tissue for lasers, 250 sheets stapled	1 pc
Sinter plate (315 mm x 239 mm x 1.5 mm; 12.4" x 9.4" x 0.06")	1 pc
Thin laminate 104 ML, 5/0 μm 305 (k) x 229 x 0.2 mm (9" x 12" x 0.008") with protective film	2 pcs
Cleaner, for removing oxide layers on copper surfaces	1 pc
Lubricant ISOFLEX TOPAS 5051	1 pc
Special ball-bearing grease Dynalub 510, 30 g (1.05 oz.)	1 pc
Protective gloves, light Nylon knit, lint-free, uncoated, size 9	1 pc
Base material FR4, pre-drilled with 2 register holes (229 mm x 305 mm x 1.5 mm (9" x 12" x 0.06"), copper 0/18 μm (0.7 mil))	2 pcs

Table 9: Starter kit ProtoLaser

Wear parts

The following wear parts are excluded from the warranty:

- Sinter plate
- Gas spring of the cover
- Felt of the extraction hood

3.3 Type label

The type label is located at the housing of the system. For information on identifying the system and the relevant equipment, specify the system model and the serial number on the type label when you contact the LPKF Service.

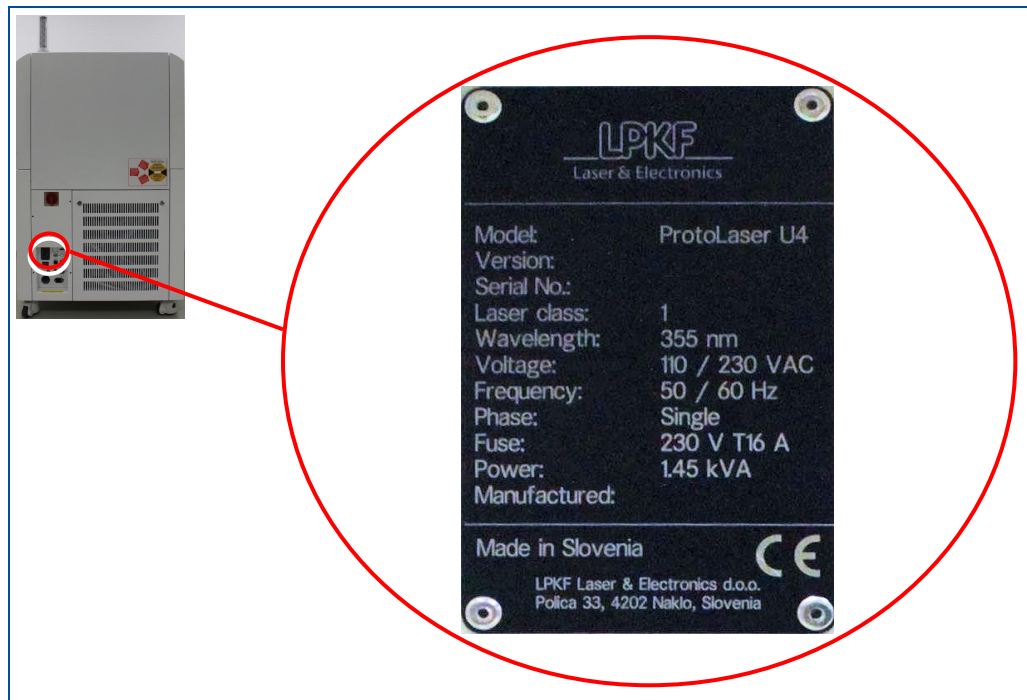


Fig. 4: Type label

Name	Description
Model	System type
Version	Version number
Serial No.	Serial number
Laser class	Laser class
Wavelength	Laser wavelength
Voltage	Operating voltage
Frequency	Line frequency
Phase	Number of phases
Fuse	Fuse protection
Power	Power consumption
Manufactured	Year of manufacture
Made in Slovenia	Country of Origin

Table 10: Type label

3.4 System components

This chapter describes the components of the system. First of all, make yourself familiar with the individual components of the system before starting the operation. Before operating the system, also inform yourself about the important software elements and the different operation modes.

3.4.1 Total view



Fig. 5: System overview with open cover

- | | | | |
|---|------------------|----|--------------------------------------|
| 1 | Cover | 6 | Button ACK |
| 2 | Processing unit | 7 | On/Off switch |
| 3 | x/y table | 8 | Emergency stop button |
| 4 | Maintenance door | 9 | Housing |
| 5 | Leveling foot | 10 | Maintenance cover in processing area |

3.4.2 Laser source

The laser source is a diode-pumped solid-state laser system that has been developed for emitting pulsed laser radiation. The laser radiation wavelength is 355 nm with a power of < 6 W. The laser has been developed for integration into an overall system. Significantly higher processing speed and very low operation costs are possible due to very high laser peak power of the system with repetition rates of up to 300 kHz. Additionally, the laser system has an excellent beam quality and pulse stability as well as precise power control.

Beam conditioner

The beam conditioner expands, deflects and focuses the laser beam.

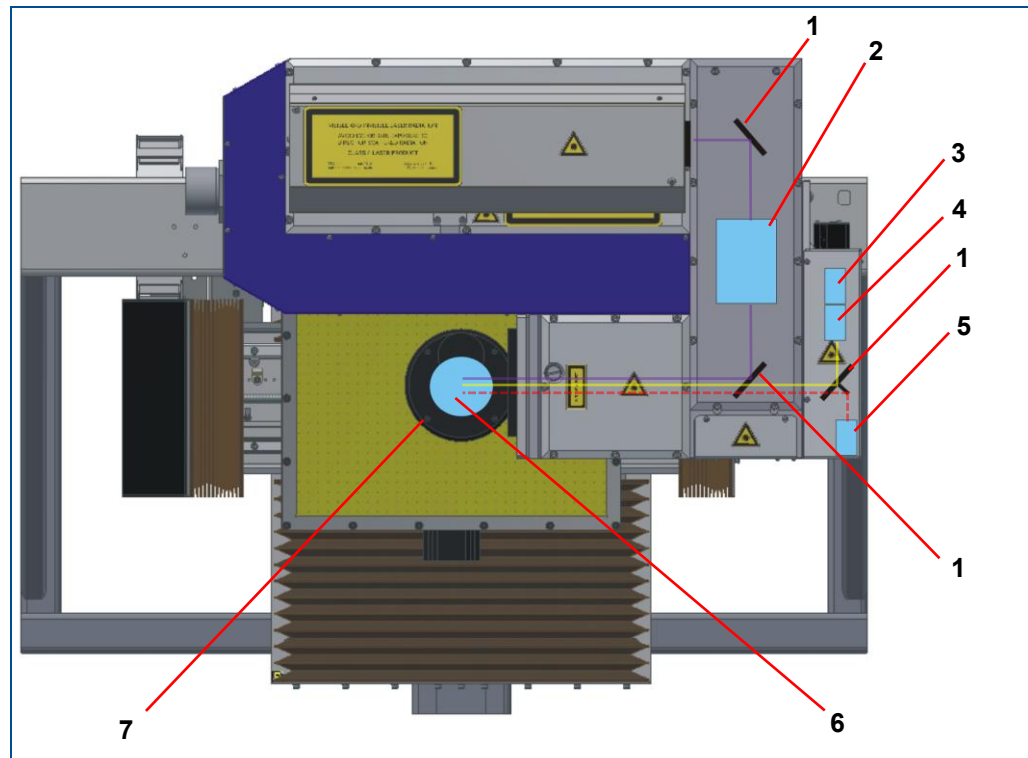


Fig. 6: Beam conditioner

- | | | | |
|---|-------------------|---|--------------|
| 1 | Mirror | 5 | Pilot laser |
| 2 | Laser safety lock | 6 | F-theta lens |
| 3 | Camera | 7 | Scanner unit |
| 4 | Camera lens | | |

Beam deflection with telecentric f-theta lens

The laser beam (3) reaches the lens (5) via two 45° deflection mirrors (2). In the scanner unit, the laser beam (3) is deflected in x and y direction (dynamic deflection) by two individually driven galvanometer scanners (1 + 6). This setup in conjunction with the telecentric f-theta lens (5) makes it possible to deflect the beam that is otherwise immobile. This produces a square image field that is called the scan field (4).

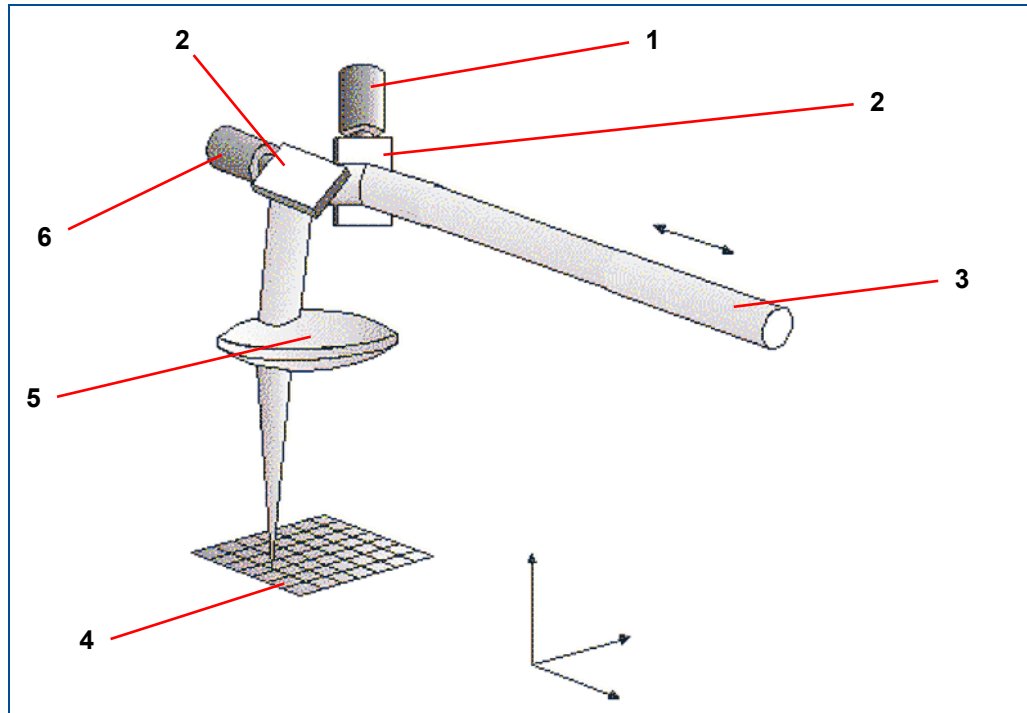


Fig. 7: Scan field creation

- | | |
|--------------------------|--------------------------|
| 1 y galvanometer scanner | 4 Scan field |
| 2 Deflection mirror | 5 Lens |
| 3 Laser beam | 6 x galvanometer scanner |

As a result of the rotation of the mirrors attached to the galvanometer scanners, the incident laser beam moves on the mirror surfaces. This causes a cushion or barrel distortion of the scan field (see following figure).

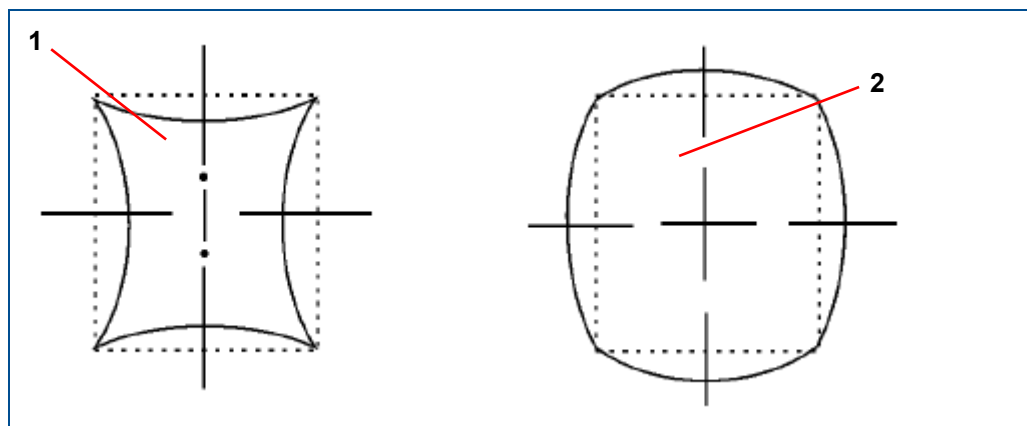


Fig. 8: Cushion and barrel distortion

- | | |
|----------------------|---------------------|
| 1 Cushion distortion | 2 Barrel distortion |
|----------------------|---------------------|

Due to the spatial distance between the two mirrors and additional effects of the lens, the real scan field is a combination of cushion distortion and barrel distortion (see following figure).

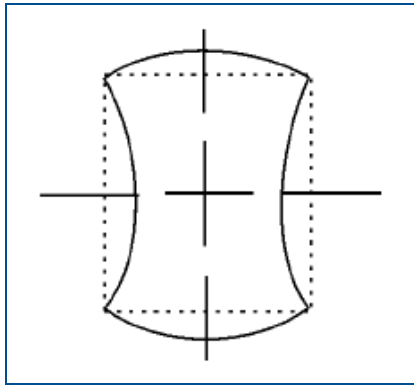


Fig. 9: Cushion-barrel distortion

To allow micro structuring without offsets, the scanner unit is calibrated so that a square scan field is achieved (see following figure).

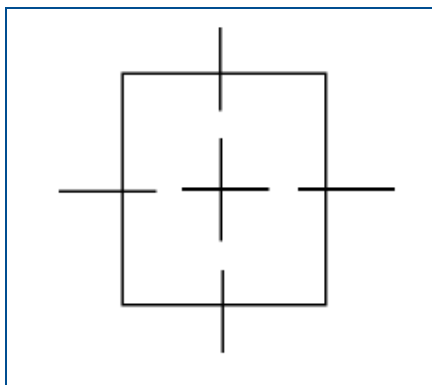


Fig. 10: Calibrated scan field

Any change of the laser focus height, e.g. by changes of the laser to camera offset, repairs or maintenance on the processing table or replacement of the sinter plate requires that the scan field is checked and calibrated anew if necessary.

The system has been calibrated ex works. However, if calibration errors should occur, contact the LPKF service. The contact details are in the first pages of this manual in the information on customer service.

3.4.3 x/y table

The x/y table moves the part precisely under the processing head. An integrated vacuum table fastens the material evenly onto the processing surface without the need for pins or clamps.

The mechanical z axis of the x/y table allows to process materials of various thicknesses. The mechanical z axis is driven by a combination of a stepper motor and a table-lifting mechanism.

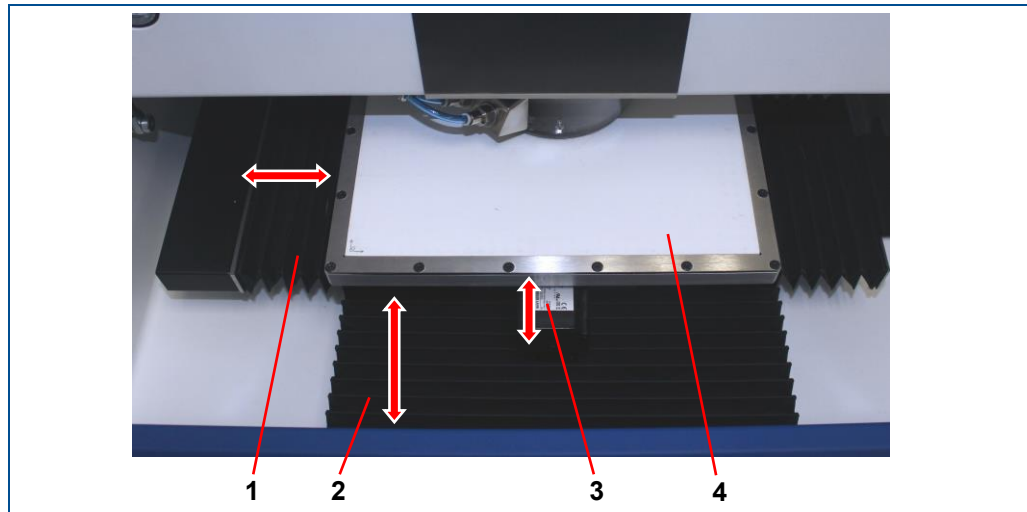


Fig. 11: x/y table

- | | |
|----------|----------------|
| 1 x axis | 3 z axis |
| 2 y axis | 4 Vacuum table |

3.4.4 Extraction hood

The extraction hood with integrated compressed-air nozzles extracts the detached copper during processing. The felt of the extraction hood rests on the material which creates a defined airflow.



Fig. 12: Extraction hood

- | | |
|---------------------------------|---|
| 1 Connector for extraction hose | 3 Compressed-air connector for compressed air nozzles |
| 2 Felt | |

3.5 Optional modules, accessories, extras

The system can be equipped with the following accessories:

- Extraction system LMD 508 with prefilter unit
- Compressor MONSUN Fast R



For more information contact the LPKF sales department or your local representative.

Extraction system

The extraction system TEKA LMD 508 is used as a standard accessory. For a detailed description of the extraction system refer to the supplied manufacturer's manual.

WARNING

Health hazard by gases or dusts!

Processing materials with laser beams can produce gases or dusts hazardous to health.

- ▶ Only process materials that are approved by LPKF.
- ▶ Always ensure that the extraction system is switched on and working properly.

CAUTION

Health hazard by insufficient filtration!

Filters cannot be cleaned or reused. If you are using saturated, defective or no filters at all, filtration of particles that can be harmful to health is not guaranteed.

- ▶ Only operate the system with installed and working filters.
- ▶ Observe the recommended maintenance intervals and replace the filters in time.
- ▶ Dispose of the saturated filters properly. Observe the local disposal regulations.

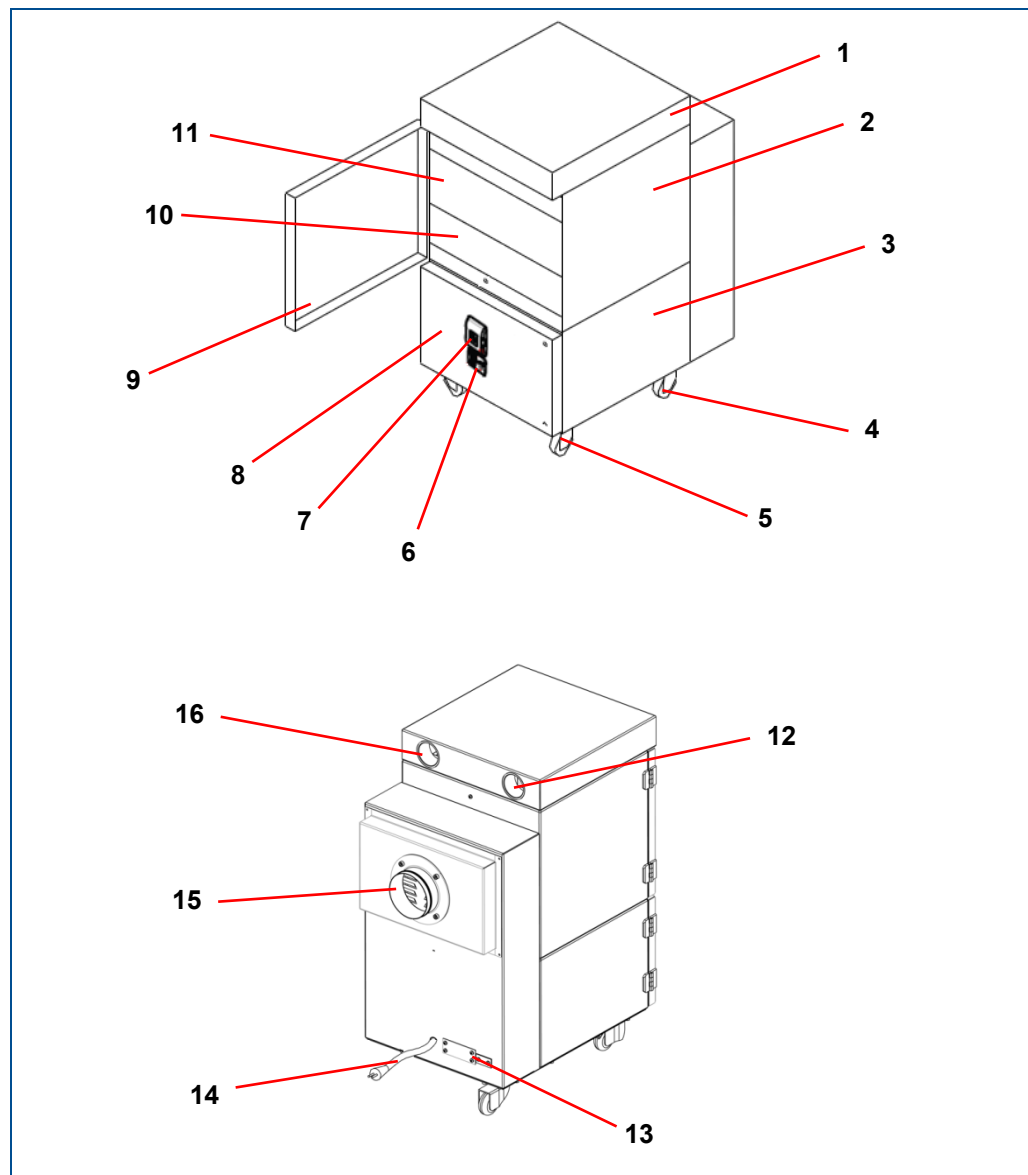


Fig. 13: Overview extraction system

- | | | | |
|---|------------------------------|----|---|
| 1 | Housing cover | 9 | Filter door |
| 2 | Filter housing | 10 | Activated carbon filter |
| 3 | Fan housing | 11 | Particle filter |
| 4 | Caster wheel | 12 | Intake fitting |
| 5 | Caster wheel with brake | 13 | Cover or Harting socket or 9-pin D-sub socket |
| 6 | Control panel | 14 | Mains cable with mains plug |
| 7 | Antenna of the ControlUnit 2 | 15 | Exhaust muffler with exhaust fitting |
| 8 | Fan door | 16 | Intake fitting |

Compressor

The compressor MONSUN Fast RL can be used for producing compressed air. For a detailed description of the compressor refer to the supplied manufacturer's manual.

WARNING

Risk of injuries by pressurized components!

Pressurized components (e.g. compressed-air supply) can move uncontrollably in case of improper handling or in case of a defect and can cause serious injuries.

- ▶ Depressurize the components before working on them. De-energize the residual energies.
- ▶ Always ensure that there is no unintended escape of compressed air.
- ▶ Defective components that are under pressure when operating the system have to be replaced immediately by sufficiently qualified personnel.



Fig. 14: Compressor



If you are using other accessories, refer to the manufacturer's manual for more information.

3.6 Connections

The connectors are located at the lower left rear of the system and are described in this chapter.

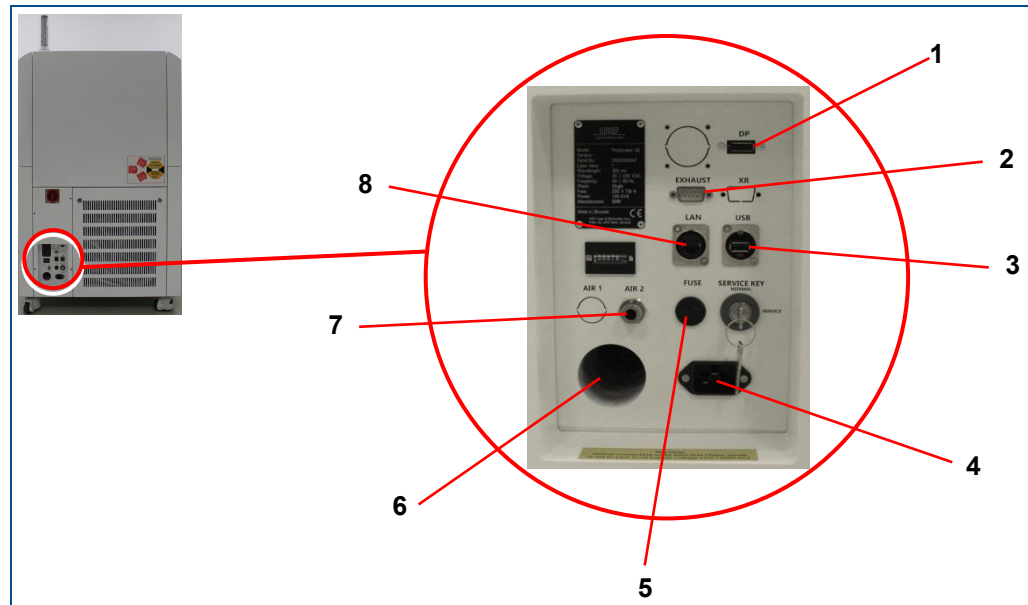


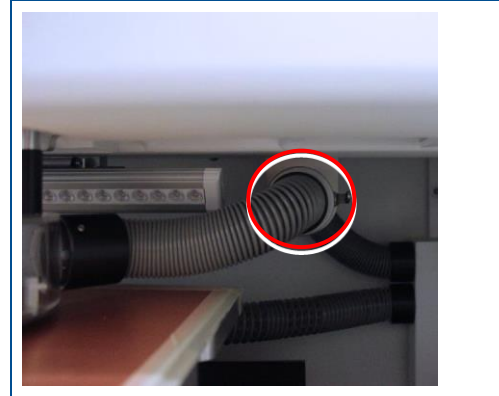
Fig. 15: Connectors

- | | | | |
|---|--|---|---|
| 1 | DisplayPort connector, for connecting the system to the screen | 5 | Fuse |
| 2 | 9-pin D-sub male connector, for connecting the extraction system | 6 | Extraction tube, for connecting to the extraction system |
| 3 | USB 2.0 socket, type B, for connecting the system to the PC | 7 | Compressed-air connector (coupling for 8 mm (0.315") outer tube diameter) for connecting to the compressed-air supply |
| 4 | Socket, for connecting the mains cable | 8 | Network connector |

3.6.1 Connections of the extraction hood



Fig. 16: Connections for compressed-air nozzles and extraction hood



Extraction manifold

The extraction manifold is at the right rear of the processing area. The control lever of the extraction manifold controls the vacuum in the extraction hood and on the x/y table.

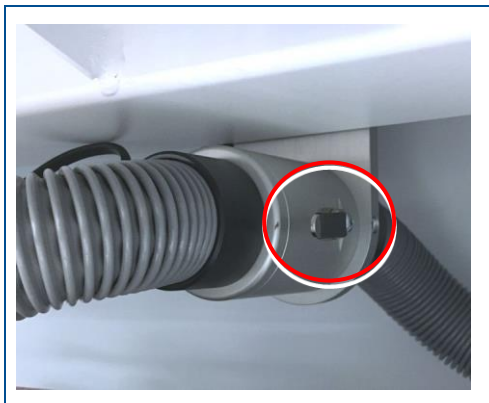


Fig. 17: Control lever in horizontal position

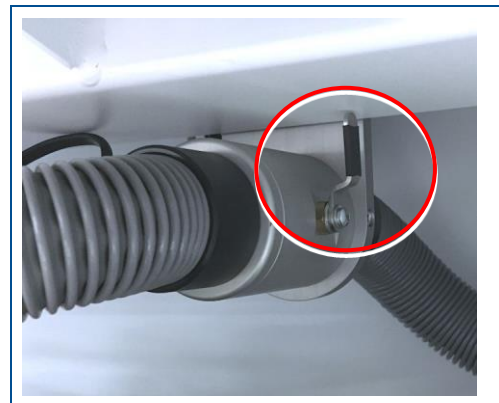


Fig. 18: Control lever in vertical position

The control lever is operated as follows:

- Turning the control lever towards the horizontal position The vacuum in the extraction hood is increased and on the x/y table it is reduced.
- Turning the control lever towards the vertical position The vacuum in the extraction hood is reduced and on the x/y table it is increased.

3.6.2 Power meter connector

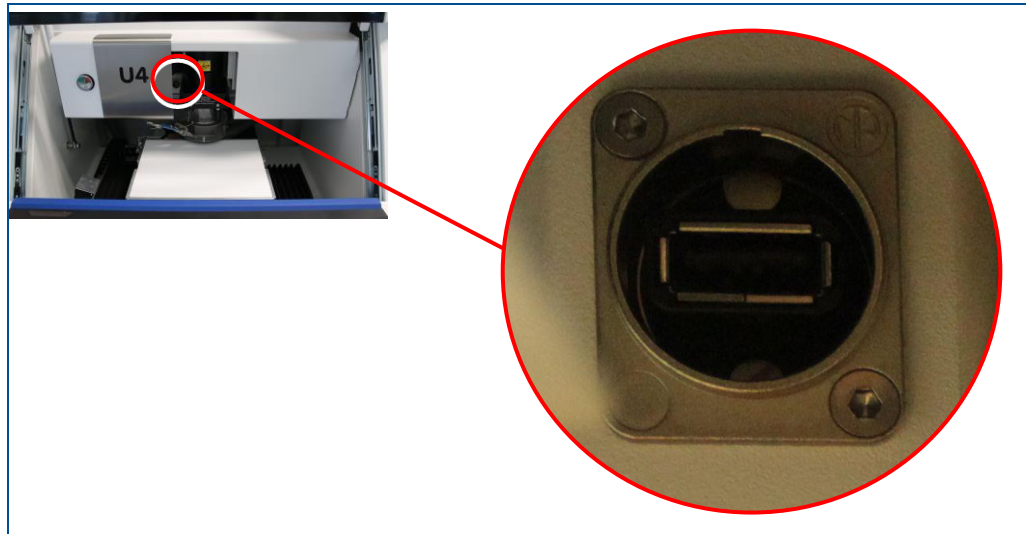


Fig. 19: USB port (power meter connector)

This port is used by the LPKF Service for connecting the power meter, if necessary.

3.6.3 Pin assignment

The system is equipped with a male 9-pole sub-D connector that provides remote control of the external extraction system. At this interface you have to connect the data cable for the extraction system to exchange control and status signals with the system.

NOTICE

Property damage by a different extraction system!

Extraction systems that are not approved by LPKF can cause system damage.

- ▶ Use extraction systems that are approved by LPKF in order to guarantee a safe use of the system and to avoid damage.
- ▶ Only use the delivered connection cable.
- ▶ If there is any doubt, contact the LPKF Service for checking compatibility of a different extraction system.

Pin	Type	Name	Description
1,2	Output	Start	Pin 1 and pin 2 not connected (max. 100 mA) Extraction system is started if pin 2 has 24 VDC.
3,4	Input	Filter full	Extraction filter full (contact closed if filter full)
5,6	Input	Extraction system is in process	Extraction system activated (contact closed if vacuum activated)
7	Output	Increase extraction power	Not connected
8	Output	Decrease extraction power	Not connected
9	Power supply	GND	Ground terminal for signal of pin 7 and pin 8 (24 V)

Table 11: Pin assignment

3.7 Displays and control elements

This chapter describes the displays and control elements of the system. First of all, make yourself familiar with the individual components of the system before starting the operation.

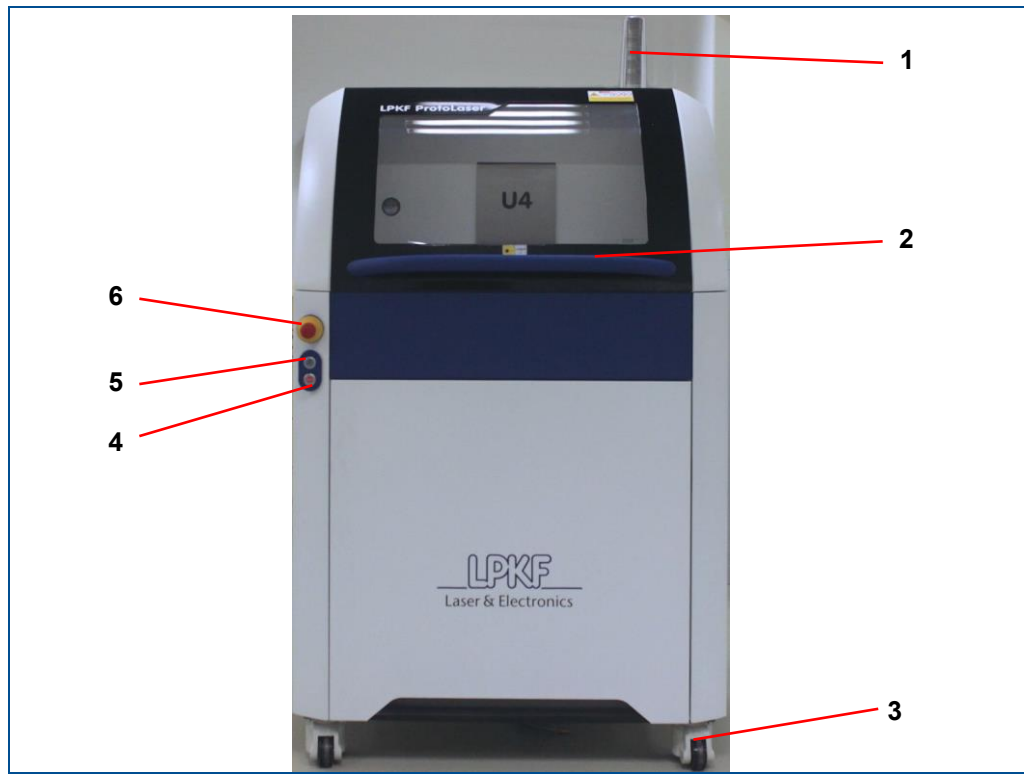


Fig. 20: Displays and control elements at the system front

- | | |
|---|-------------------------|
| 1 Stack light | 4 Button ACK |
| 2 Handle | 5 On/Off switch |
| 3 Adjustment lever of the leveling foot | 6 Emergency stop button |




Figure	Description
	<p>The stack light (1) indicates the system's operating state. The following operating states are displayed with the stack light:</p> <p>Green: Ready for operation The system is ready for operation or already in operation. No fault is present.</p> <p>Orange: Service mode activated Laser class 4 is possible because safety devices have been shut off.</p> <p>Red: Fault Work cannot be continued until the fault is successfully reset by the user in the fault monitor.</p> <p>Blinking red The emergency stop button has been pushed.</p>
	The handle (2) is used for opening and closing the cover.
	The adjustment lever (3) with toggle function is used for height adjustment of the leveling foot and locking it.



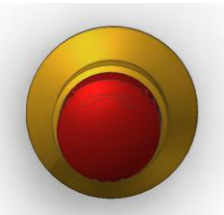
Figure	Description
	By pressing the button <i>ACK</i> , the operating personnel confirms that the system is in a fault-free state.
	After switching on the main switch, the button for starting the system has to be pressed additionally. In daily operation of the system, this button (5) can be used for switching the system on and off. If the system is switched on, this button is lit blue.
	Pushing the emergency stop button (6) immediately switches off the laser and stops the motorized axes. This stop is only intended for an emergency.

Table 12: Displays and control elements at the system front

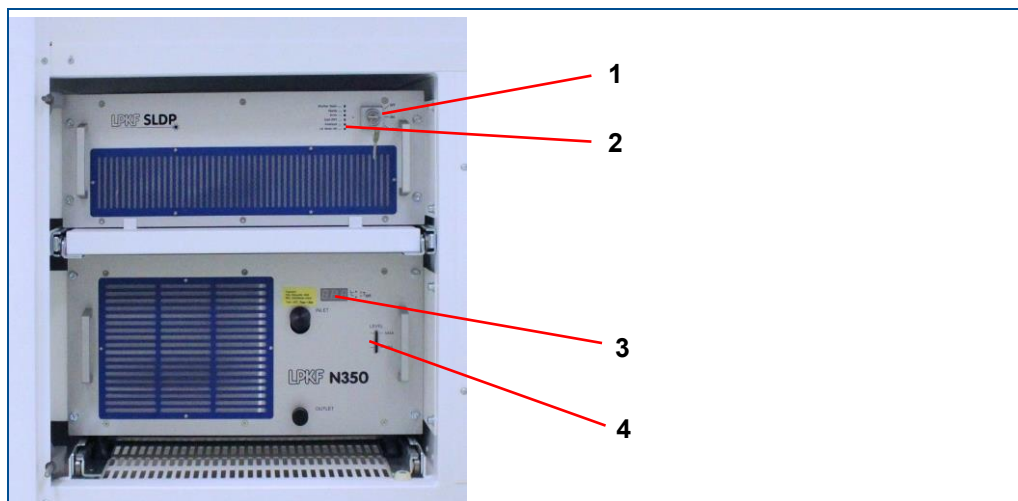


Fig. 21: Displays and control elements behind maintenance door

- 1 Key switch for laser control
- 2 Display of laser control
- 3 Temperature display of chiller
- 4 Fill level indicator of chiller

Figure	Description
	<p>The key switch of the laser control is only relevant for the LPKF Service.</p>
	<p>The display of the laser control indicates the different states of the laser.</p>
	<p>The temperature display of the chiller shows the current temperature of the coolant.</p>
	<p>The fill level indicator of the chiller shows the current fill level.</p>

Table 13: Displays and control elements behind maintenance door

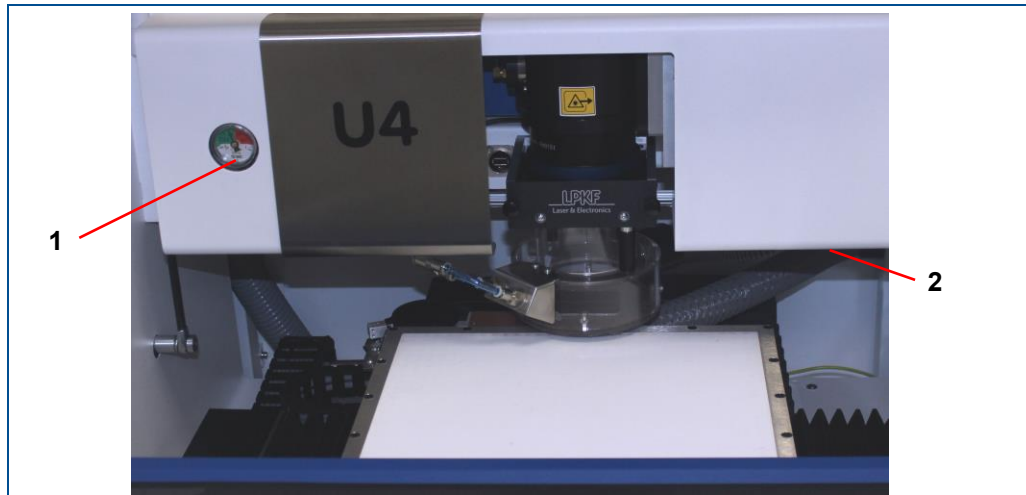


Fig. 22: Displays and control elements in processing area

- 1 Compressed-air filter regulator with pressure gauge (filter regulator not visible in figure)
- 2 Control lever of extraction manifold

Figure	Description
	<p>The filter regulator (1) filters the compressed air and reduces the input pressure. The filter regulator is preset to a maximum permitted output pressure of 4.0 bar (0.4 megapascal [MPa]).</p>
	<p>The control lever (2) of the extraction manifold controls the vacuum in the extraction hood and on the x/y table.</p>

Table 14: Displays and control elements in processing area

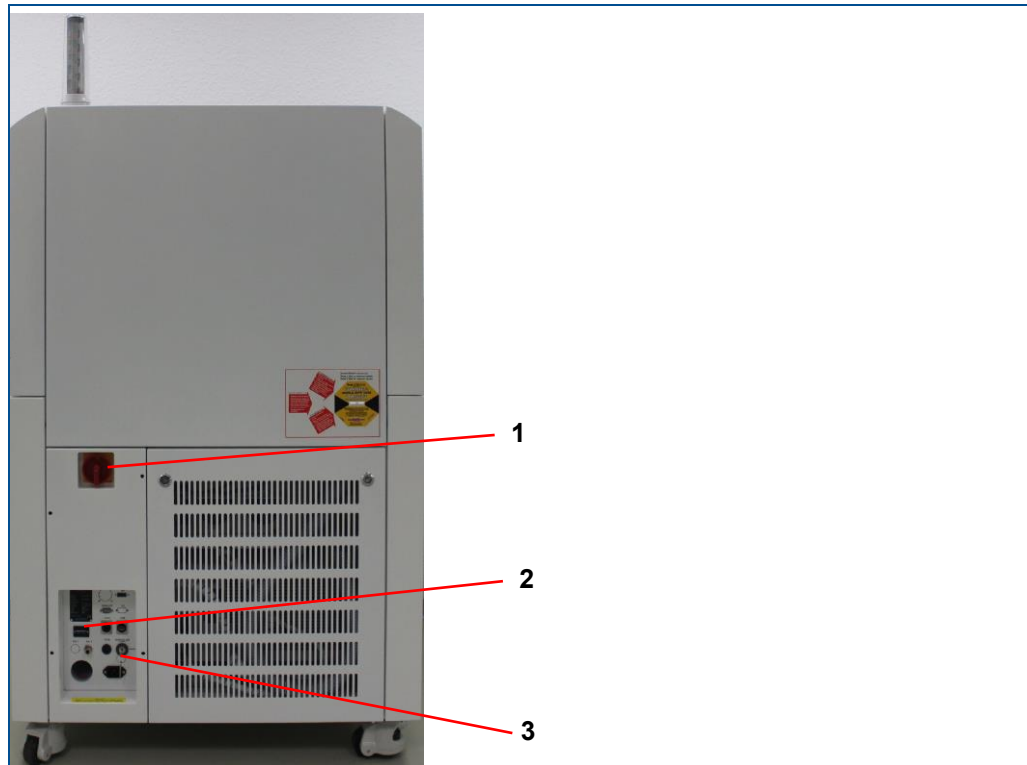


Fig. 23: Displays and control elements at the rear of the system

- 1 Main switch
- 2 Operating hours counter
- 3 Key switch *SERVICE KEY*




Figure	Description
	The main switch (1) switches on or off the mains power supply.
	The operating hours counter (2) displays the accumulated operating hours.
	The key switch <i>SERVICE KEY</i> (3) is located at the rear of the system and may only be used by authorized persons. The key switch <i>SERVICE KEY</i> switches the system into the service mode. The horizontal key position of the key switch <i>SERVICE KEY</i> switches on the service mode; the vertical key position of the key switch <i>SERVICE KEY</i> switches off the service mode.

Table 15: Displays and control elements at the rear of the system

3.8 Software

The system is operated with the preinstalled system software CircuitPro PL. The system software is used for preparing the layout data and for controlling the system.



For detailed information on operating the system software press **F1** to invoke the help function.

System requirements CircuitPro PL

The following table lists the recommended system configuration for working with CircuitPro PL:

Component	System configuration
CPU	Dual Core 2.6 GHz
RAM	8 GB
Memory requirements	2 GB
Graphics board	With 1 GB dedicated memory (non-shared memory) LPKF discourages the use of the following graphics boards because they cause problems: <ul style="list-style-type: none"> • Intel 82945G
Screen resolution	1680 x 1050 pixels
Operating system	Windows 7 (64bit)

Table 16: Recommended system configuration CircuitPro PL

The following table lists the minimum system configuration for working with CircuitPro PL:

Component	System configuration
CPU	2 GHz
RAM	4 GB
Memory requirements	2 GB
Graphics board	With 128 MB dedicated memory (non-shared memory) LPKF discourages the use of the following graphics boards because they cause problems: <ul style="list-style-type: none"> • Intel 82945G
Screen resolution	1280 x 768 pixels
Supported operating systems	Windows 7 (32bit/64bit) Windows 8.1 (64bit) Windows 10 (64bit)

Table 17: Minimum system configuration CircuitPro PL

■ **Starting the system software**

- ▶ Double-click on the following symbol to start the system software CircuitPro PL.



Fig. 24: Desktop icon CircuitPro PL

- CircuitPro PL is started and the following user interface is displayed:

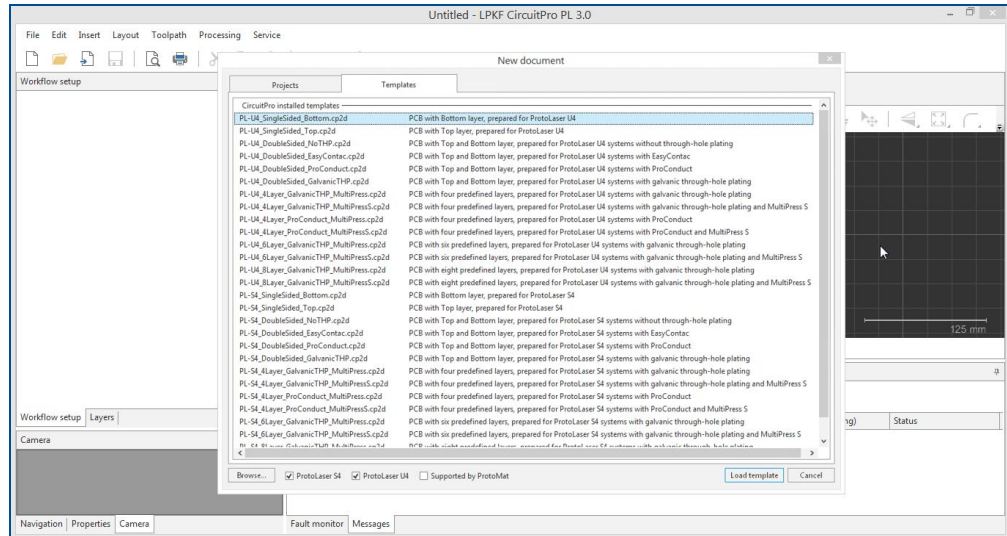


Fig. 25: User interface CircuitPro PL

- ☑ The system software has been started.

3.9 Modes of operation

The system can be operated in the following modes:

Production mode

The system is normally operated in the production mode. The stack light is lit **green**. In the production mode, the system can execute movements and emit laser radiation while the cover is closed.

Service mode

The service mode may only be activated by the LPKF Service because switching from laser class 1 to laser class 4 constitutes a hazard. The signal light is lit **orange**.

Switching between the modes of operation

Ensure that the following prerequisites are fulfilled before performing the described tasks:

Prerequisites

- Wear laser protective glasses

The key switch *SERVICE KEY* is located at the rear of the system and may only be used by authorized persons. The key switch switches the system into the service mode which deactivates the safety devices.

! WARNING

Risk of injury by laser radiation!

As soon as the system is switched to the service mode it is classified as laser class 4.

- ▶ Always wear your personal protective equipment.
- ▶ Never look directly into the laser beam.

The horizontal key position of the key switch *SERVICE KEY* switches on the service mode; the vertical key position of the key switch *SERVICE KEY* switches off the service mode.

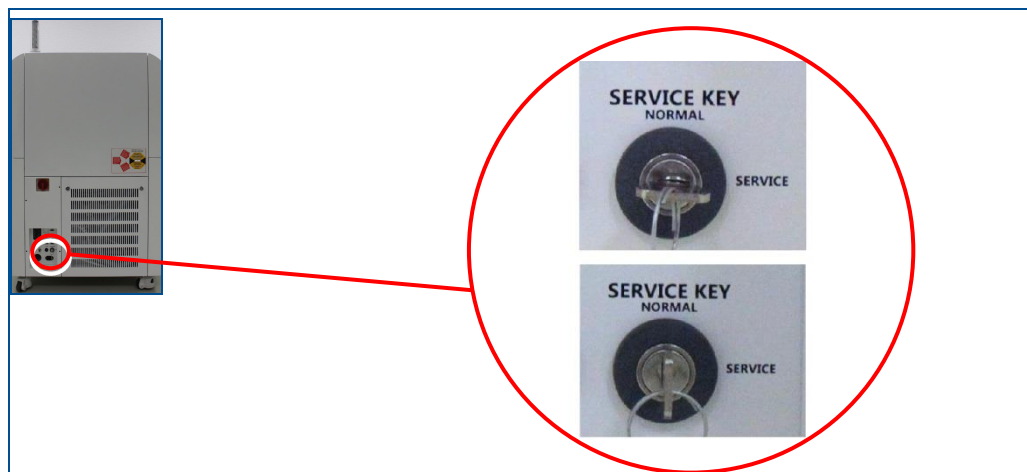


Fig. 26: Key switch *SERVICE KEY*

4 Transport and storage

This chapter contains important information on transport, packaging and storage of the system.

NOTICE

System damage by improper transport!

Improper transport can cause damage to the system.

- ▶ Transport the system cautiously to the place of installation.
- ▶ Observe the symbols on the packages.
- ▶ Remove the packaging only directly before system installation.

4.1 Transport inspection

Check the delivered goods immediately upon receipt for completeness and for transport damage.

If transport damage is evident or a ShockWatch® indicator or a TiltWatch® indicator has been activated, proceed as follows:

- ▶ Do not accept the delivery or only with reservations.
- ▶ Record the extent of damage on the transport documentation or on the delivery note of the transport company.
- ▶ Initiate a complaint.

4.2 Packaging

The packaging is chosen according to the transport conditions.

The packaging is to protect the system from transport damage, corrosion, and other kinds of damage until installation.

- ▶ Keep the packaging in its original form.
- ▶ Only remove the packaging just before installation.

Handling packaging material

- ▶ Dispose of the packaging material according to the current laws and local regulations.

NOTICE

Environmental hazard by wrong disposal of packaging!

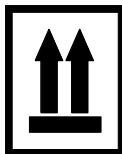
Wrong disposal of packaging material can cause environmental hazards.

- ▶ Dispose of the packaging material environmentally friendly.
- ▶ Observe the local disposal regulations and hire a specialized company for the disposal, if necessary.

The system may only be shipped in the original packaging of LPKF. Contact the LPKF Service if you need the packaging.

4.2.1 Symbols on the packaging

Observe the following symbols on the packaging when transporting the system:

**Top**

The arrowheads of the symbol indicate the top side of the package. These always have to point upwards, otherwise, the contents could be damaged.

**Keep dry**

Protect packages against moisture and keep them dry.

**Fragile**

Identifies packages with fragile or sensitive contents. Handle the package with care, do not drop, and do not subject it to shocks.

4.2.2 Unpacking the system

The following describes how to unpack the system. Observe also the unpacking instructions.

■ Unpacking the system

1. Remove the screws from the lid.
2. Lift off the lid.



Fig. 27: Lifting off the lid

3. Remove the edge protectors.
4. Remove the screws from the front of the packaging.

5. Remove the front.



Fig. 28: Packaging without front

6. Remove the screws from the side and rear panels.

7. Remove the side and rear panels.



Fig. 29: Packaging without panels

8. Cautiously remove the foils and the edge protectors.
The transport ramps are on the inside of the front panel.



9. Remove the screws of the transport ramps.



Fig. 30: Transport ramps

10. Put the transport ramps onto the front edge of the box floor.
11. Align the transport ramps with the centers of the caster wheels of the system.



Fig. 31: Placing the transport ramps

12. Screw the transport ramps onto the box floor.



Fig. 32: Fastening the transport ramps

13. Pull on the ring (3) to pull out the height adjustment lever (2) of the leveling foot.

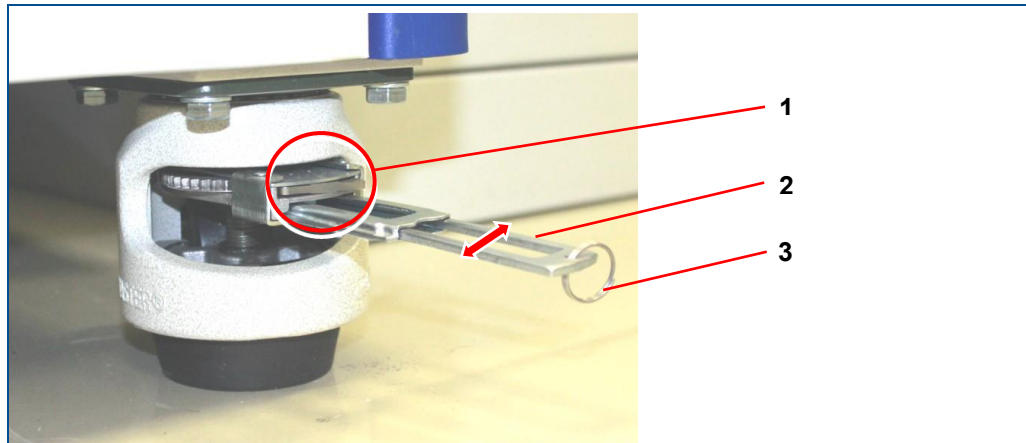


Fig. 33: Leveling foot

- | | |
|---|--|
| <ol style="list-style-type: none"> 1 Rocker switch for raising/lowering the leveling foot 2 Height adjustment lever | <ol style="list-style-type: none"> 3 Ring for pulling out the height adjustment lever |
|---|--|

14. Push all rocker switches (1) **to the right** to lower the leveling feet and thus lift the system.
15. Adjust all leveling feet using the adjustment levers (2) until the system is lifted off the transport supports.

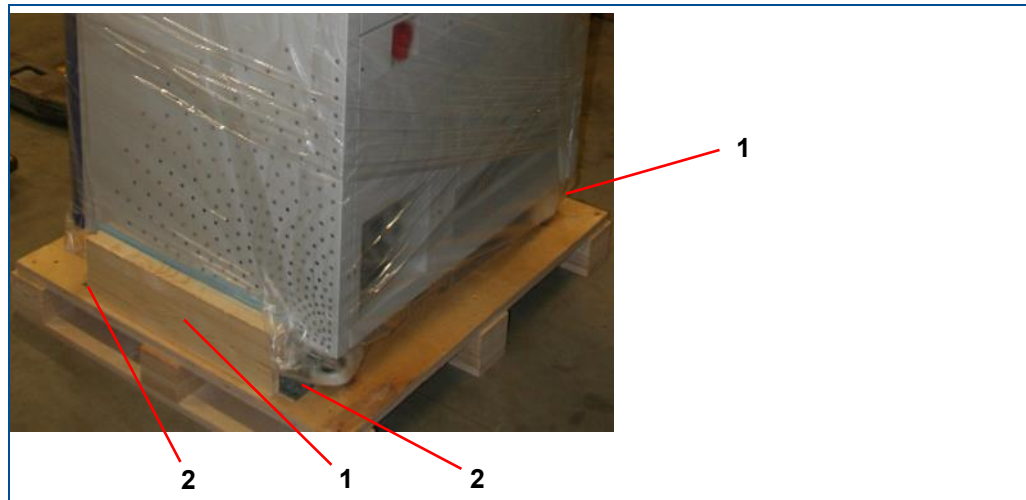


Fig. 34: Transport supports

1 Transport support

2 Fastening bracket

16. Remove the screws from the four fastening brackets (2) of the transport supports (1).
 17. Remove both transport supports (1).
 18. Push all rocker switches (1) (see figure 33) **to the left** to raise the leveling feet and thus unlock the leveling feet.
 19. Adjust all leveling feet using the adjustment levers (3) (see figure 33) until the system stands on all four wheels.
 20. Push the adjustment levers (2) (see figure 33) back into their resting positions.
 21. Cautiously roll the system from the box floor via the transport ramps.
- The system has been unpacked.

4.3 Transporting the system



Before transporting a system, the LPKF Service has to be contacted. The only exception is the transport over short distances (see the following chapter).

Ensure that the following prerequisites are fulfilled before performing the described tasks:

Prerequisites

- Wear safety shoes
- Wear protective gloves

Deactivate the system using the main switch at the rear of the system before transport (see chapter 1.9). The cover must remain closed to prevent dirt from entering.

4.3.1 Moving the system over short distances

CAUTION

Risk of injury by sharp edges!

When leveling the system (when adjusting the height of the leveling feet), sharp edges of the adjusting lever can cut your hands.

- ▶ Always wear protective gloves.

NOTICE

Property damage by missing transport lock!

Transporting the system without installed transport locks can cause property damage.

- ▶ Only transport the system with installed transport locks.

The system has four leveling feet with wheels and is thus easy to transport. The system can be transported over short distances (e.g. within a room or a building) using the four leveling feet. To be able to move the system, the locks of the leveling feet have to be loosened first.

Loosening the locks of the leveling feet

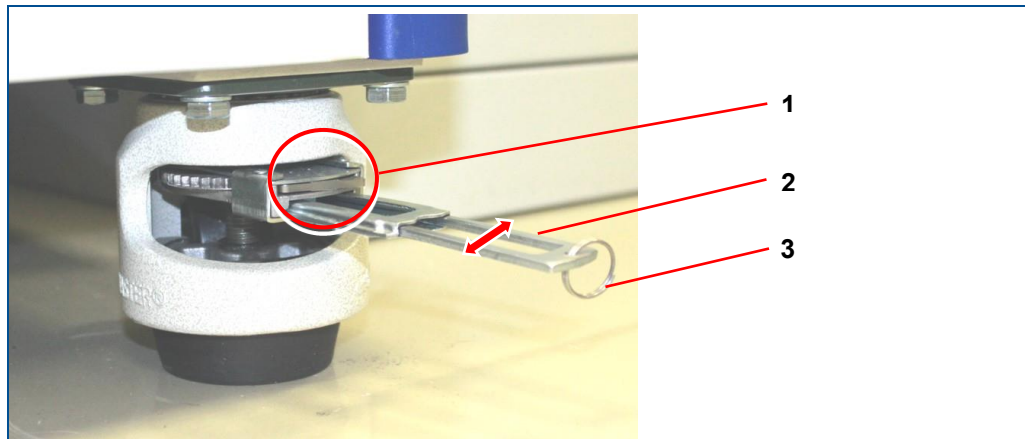


Fig. 35: Leveling foot

- | | |
|--|--|
| <p>1 Reversing lever for adjusting the leveling feet upwards or downwards</p> <p>2 Height adjustment lever</p> | <p>3 Ring for pulling out the adjusting lever.</p> |
|--|--|

1. Pull the ring (3) to pull out the height adjustment lever (2) of the leveling foot.
2. Adjust the reversing lever (1) to the **left** for turning the leveling feet upwards and for loosening their locks.
3. Repeat the steps 1 and 2 for the rest of the leveling feet until the locks are loosened.

- The locks of the leveling feet have been loosened.

Moving the system over short distances

1. Switch off the system and ensure that the locks of all leveling feet are disengaged.
2. Disconnect the following connections (see chapter 3.6):
 - Mains cable of the system
 - Mains cable of the extraction system
 - Control cable
 - Extraction hose
 - USB cable
 - Network cable
 - DisplayPort cable
 - Compressed-air supply
3. Move the system over a short distance to the desired place.



Carefully reconnect all connections mentioned above to the system before startup. Pay special attention to fastening the extraction hose.

4. Level the system (see chapter 4.3.2).
5. Secure the system at the place of destination with the locks of the leveling feet.

- The system has been moved over a short distance.

4.3.2 Leveling the system

After the final position for the system is determined, the system has to be leveled using the four leveling feet.

Ensure that the following prerequisites are fulfilled before performing the described tasks:

Prerequisites

- x/y table is at its center position.

Spare parts and auxiliaries

- Precision frame spirit level

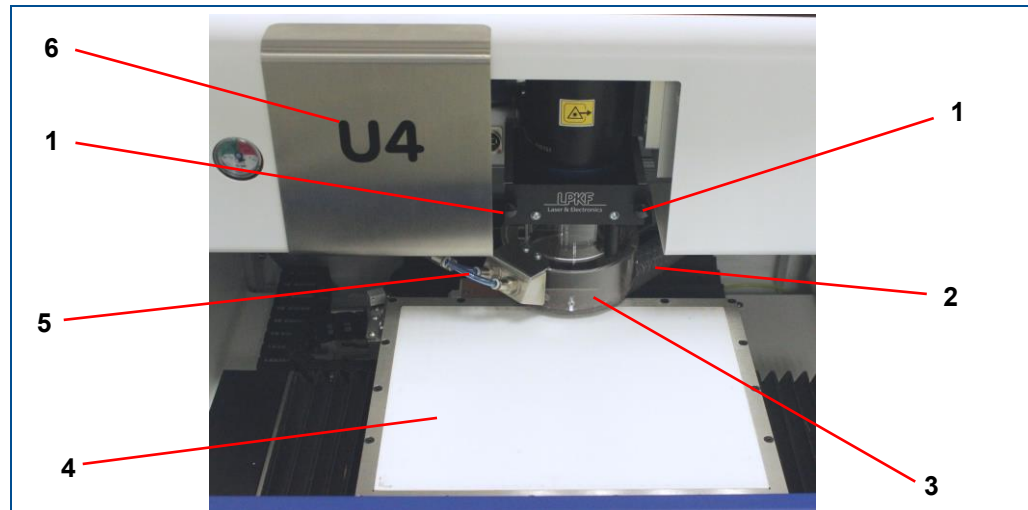


Fig. 36: System with open cover

- | | |
|-------------------------|--|
| 1 Screw extraction hood | 4 Sinter plate |
| 2 Extraction hose | 5 Compressed-air tube |
| 3 Extraction hood | 6 Maintenance cover in processing area |

■ Leveling the system

1. Open the cover.
2. Open the maintenance door in the processing area (6).
3. Disconnect the compressed-air tube (5) and the extraction hose (2) from the extraction hood (3).
4. Remove the screws (1) of the extraction hood.
5. Pull out the extraction hood towards you.
6. Remove the sinter plate (4) from the x/y table.



When opening the system for the first time, an acceptance sample and an information sheet are on the sinter plate.

7. Clean the x/y table, if necessary.
8. Pull on the ring (see chapter 4.3.2) to pull out the height adjustment lever of the leveling feet.
9. Perform one of the following steps:
 - Push the rocker switch **to the right** to **lower** the leveling foot.
 - Push the rocker switch **to the left** to **raise** the leveling foot.

- Level the system with load on all leveling feet in x and y direction using a precision frame spirit level.

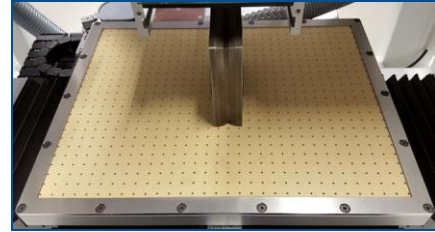
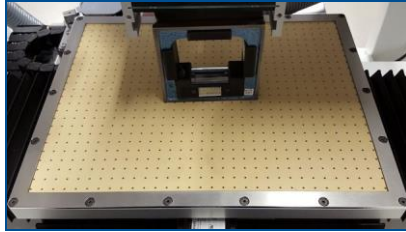


Fig. 37: Precision frame spirit level

- Push the adjustment levers of all leveling feet back into their resting positions.
 - Reinsert the sinter plate.
 - Reassemble the mentioned components in reverse order.
- The system is leveled.

4.4 Storage

- ▶ Store the system in its original packaging according to the symbols on the packaging.
- ▶ Store the packages under the following conditions:
 - Do not store outdoors.
 - Store dry and dust-free.
 - Do not expose to aggressive substances.
 - Protect against sunlight.
 - Storage temperature: 15 °C - 35 °C (59 °F - 95 °F)
 - Relative air humidity: 60 % max, non-condensing.
 - If storing for more than 3 months, check the general condition of all components and the packaging on a regular basis.

When putting the system out of operation and into storage over a longer period, ensure that the storage room is clean, almost dust-free, and has a sufficient loadbearing capacity.

5 First startup

This chapter contains important information on first startup of the system.

5.1 Safety

Observe the following safety instructions for the first startup of the system:



LPKF recommends to have the LPKF Service perform the first startup. For further information on an optional training contract or installation contract, contact the LPKF Service.

WARNING

Accident hazard due to insufficiently qualified personnel!

Insufficiently qualified personnel cannot assess the risks of using the system and put themselves and others in danger.

- ▶ Allow only qualified personnel to use the system.
- ▶ Keep insufficiently qualified personnel out of the working area.

CAUTION

Tripping hazard by hoses and cables!

Hoses and cables are routed to the system. If the hoses and cables are laid inappropriately they pose a tripping hazard for the operating personnel.

- ▶ Always ensure that the hoses and cables do not pose a tripping hazard.

NOTICE

Property damage by moisture during transport/storage!

When transporting or storing the system, moisture can cause damage to the system.

- ▶ Ensure that there is no moisture in the system.
- ▶ Before first startup of the system wait approx. 24 hours to allow the system to acclimatize.

5.2 Requirements of the place of installation

Check the system for transport damage before the installation is started. The system has to be transported to the desired place of installation. Transport the system in its packaging using a hand pallet truck. The total weight of the system has to be considered! Only when the system is at its place of installation it is leveled.

5.2.1 Climatic conditions

The following climate conditions have to be ensured for operating the system:

Climatic conditions

Data	Value	Unit
Temperature range (operation)	22 ± 2	°C
Temperature range (storage, transport)	10 to 40, 0 to 50	°C
Max. humidity, non-condensing	< 60	%

5.2.2 Minimum required space

System dimensions

- Width 910 mm (~35.8")
- Depth 795 mm (~31.3")
- Height 1650 mm (~65.0")

Minimum required space for operation and maintenance

- Width 2375 mm (~93.5")
- Depth 2000 mm (~78.7")
- Height 1765 mm (~69.5")

An additional space of 750 mm (~29.5") is required at the system front to open the maintenance door. Do not block this area because it is a working space for operation and maintenance.

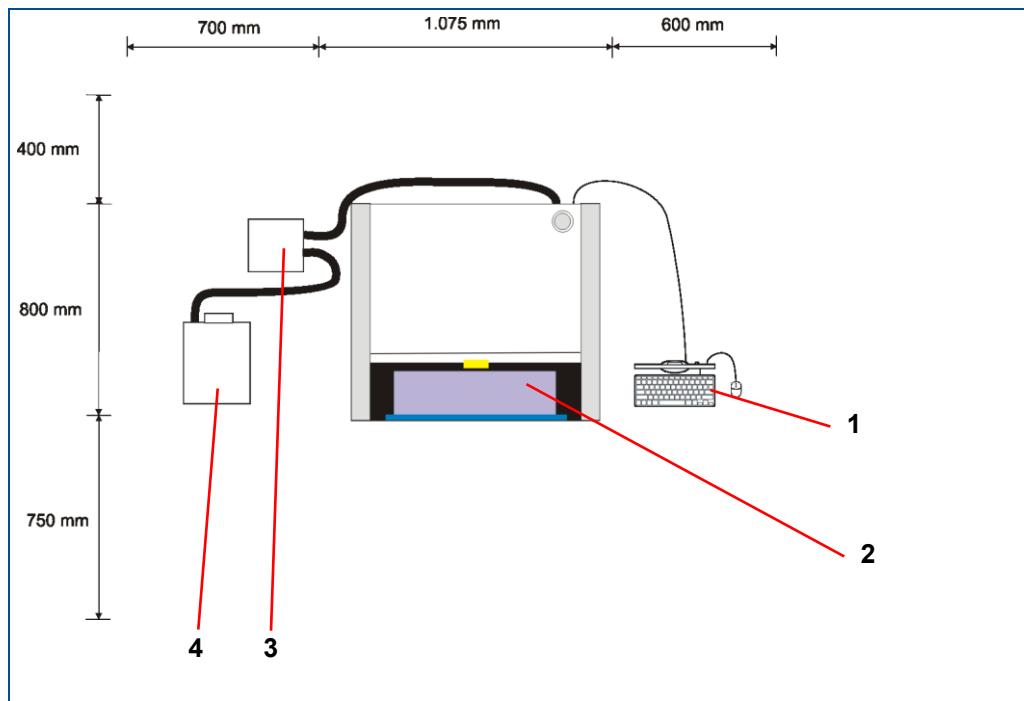


Fig. 38: Minimum required space

- | | |
|--|---------------------|
| 1 Screen, keyboard, and mouse (recommended position) | 3 Prefilter unit |
| 2 System | 4 Extraction system |

5.2.3 Workplace of the operating personnel

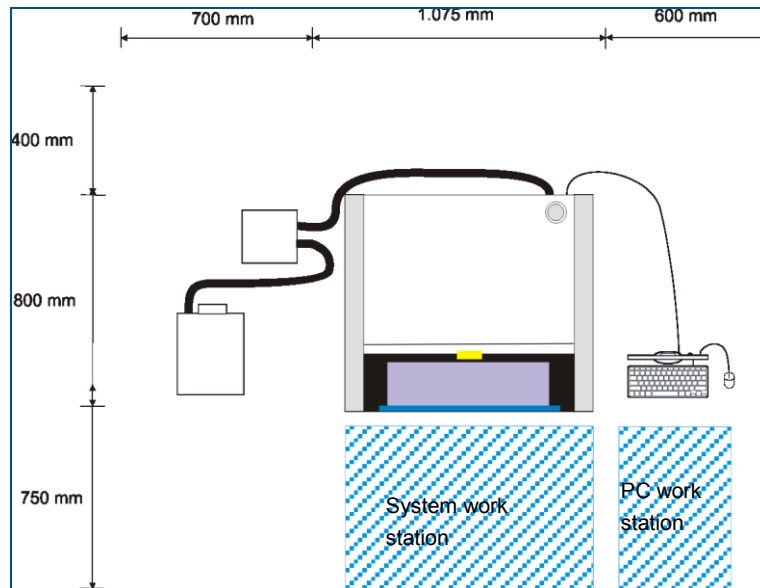


Fig. 39: Workplace of the operating personnel

The system may only be operated by one person. The system is operated according to its intended use at the following work stations:

- System work station
The system work station is used for loading and unloading the system.
- PC work station
The PC work station is used for monitoring the production and for controlling the system.

5.2.4 Floor

The floor has to be level and antistatic, and has to have a sufficient load-bearing capacity for the total weight of the system (**350 kg**).



LPKF recommends using flagstone for the flooring.

Load capacity

Data	Value	Unit
Min. distributed load	5.1	kN/m ²
Min. point load on an area of 0.00196 m ²	0.835	kN

► The system should be installed on a vibration-damped floor.

LPKF will gladly advise you on suitable damping measures such as active and passive vibration-dampers or vibration-damping mats. LPKF assumes no liability for inaccuracies and/or damage due to inadequate vibration damping.

5.2.5 The system's center of gravity

The following figure shows the center of gravity of the system:

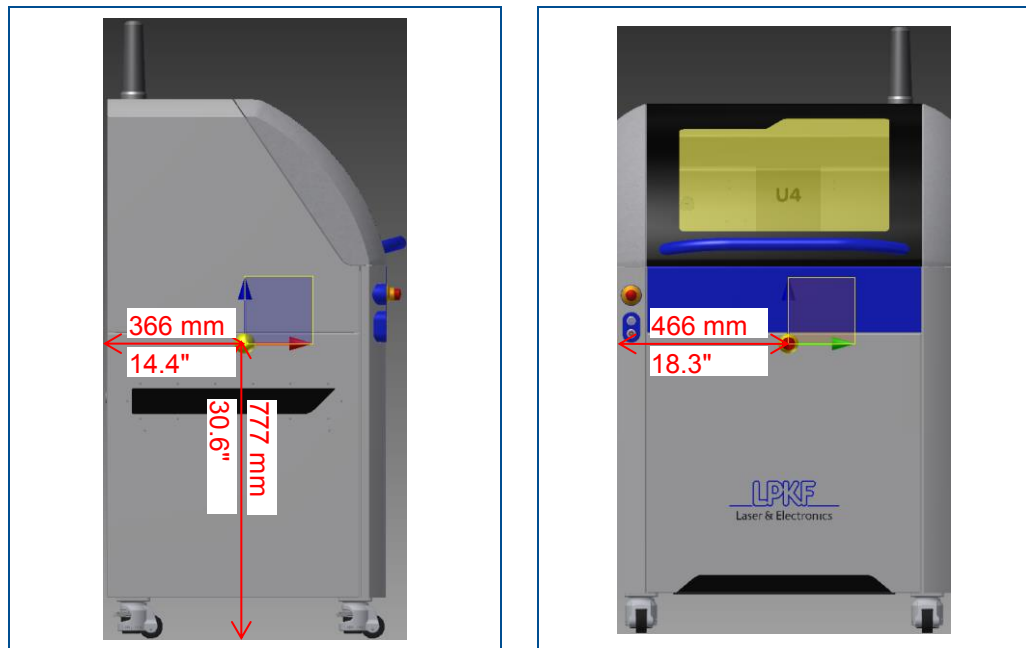


Fig. 40: Center of gravity of the system

5.2.6 Connections provided by the customer

The following connections have to be available for the first startup:

Electrical data

Data	Value	Unit
Power supply	110/230	V
	50/60	Hz
Power rating	~1.4	kW
Leakage current	~2.15	mA

Pneumatic data

Data	Value	Unit
Pressure	8	bar
Flow rate	450	NI/min

Compressed-air purity acc. to ISO 8573-1:2010-04

Data	Value	Unit
Solid particles	1	Class
Water	4	Class
Oil	1	Class

5.3 Preparations

Before the system is installed, you have to consider and ensure the following:

- A suitable extraction system has to be provided. LPKF recommends the use of the LMD 508 extraction system. This is optionally available at LPKF.
- Provide sufficient space at the place of installation.
- Ensure tidiness and cleanliness at the place of installation.
- Provide the connection materials (hoses, tubes, cables etc.).
- The room has to be clean and almost dust-free.
- Stick the corresponding safety signs in your national language on top of the safety signs that have been applied to the system. Apply the safety signs in the language that is used at the workplace additionally (see page 23).
- Ensure that the system is leveled (see page 62).
- Remove the transport locks of the system (see page 69).
- Fill the coolant into the chiller (see page 73).
- Check the local mains voltage setting of the chiller (see page 75).

5.3.1 Removing the transport locks

The transport locks have to be removed before the system can be put into operation. The chiller and the x/y table are secured with transport locks.

NOTICE

Property damage by missing transport lock!

Transporting the system without installed transport locks can cause property damage.

- ▶ Only transport the system with installed transport locks.

Chiller

The chiller is secured with two transport brackets. The transport brackets are behind the front cover.

Ensure that the following prerequisites are fulfilled before performing the described tasks:

Prerequisites

- Mains cable of the system is not connected.

Spare parts and auxiliaries

- Hex key 5 mm

■ Removing the transport locks of the chiller

1. Pull on the lower left edge of the maintenance door to open it.



Fig. 41: Opening the maintenance door

- Remove the screws (**3, 4, 7, 8**) that fasten the transport brackets (**2, 10**) to the base frame.



Put the **screw with rubber stopper (8)** aside, it will be used in one of the next steps.

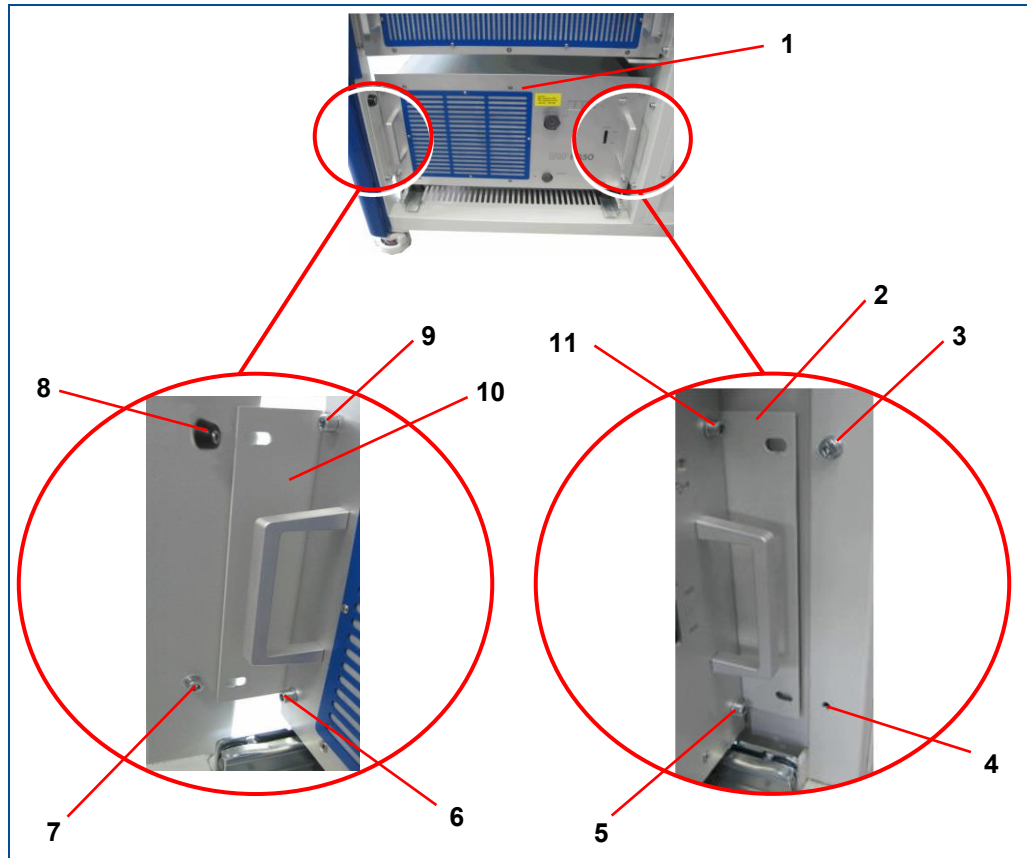


Fig. 42: Transport lock for chiller

- | | |
|---|---|
| 1 Chiller | 7 Screw (fastening transport bracket to base frame) |
| 2 Transport bracket | 8 Screw with rubber stopper (fastening transport bracket to base frame) |
| 3 Screw (fastening transport bracket to base frame) | 9 Screw (fastening transport bracket to chiller) |
| 4 Screw (fastening transport bracket to base frame) | 10 Transport bracket |
| 5 Screw (fastening transport bracket to chiller) | 11 Screw (fastening transport bracket to chiller) |
| 6 Screw (fastening transport bracket to chiller) | |

- Pull out the chiller until the transport brackets protrude from the base frame.
- Remove the screws (**5, 11, 6, 9**) that fasten the transport brackets to the chiller.
- Remove the transport brackets (**2, 10**).

6. Push the chiller into the base frame.



Pushing in the chiller is hampered by a detent at the full extent of the guiding rail.

The chiller can be moved freely.

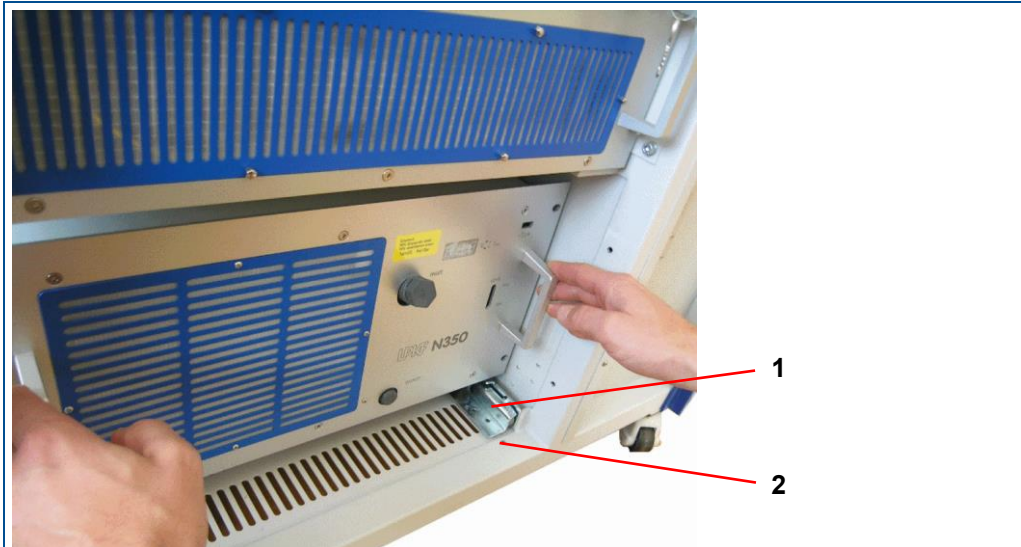


Fig. 43: Chiller

1 Guiding rail

2 Position of the screw with rubber stopper

7. Insert the screw with rubber stopper into the threaded hole in front of the guiding rail and fasten it to secure the chiller.

8. Close the maintenance door.

The transport locks of the chiller have been removed.



Store the transport brackets in a dry place in immediate vicinity of the system. Reinstall the transport brackets for securing the chiller every time the system has to be transported.

x/y table

The x/y table is secured with two bolts. The bolts are located beneath the bellows on the left and right side of the x axis.

Ensure that the following prerequisites are fulfilled before performing the described tasks:

Prerequisites

- The mains cable of the system is not connected.

■ Removing the transport locks of the x/y table

1. Open the cover.
2. Cautiously push the bellows of the x axis (1) to the side.

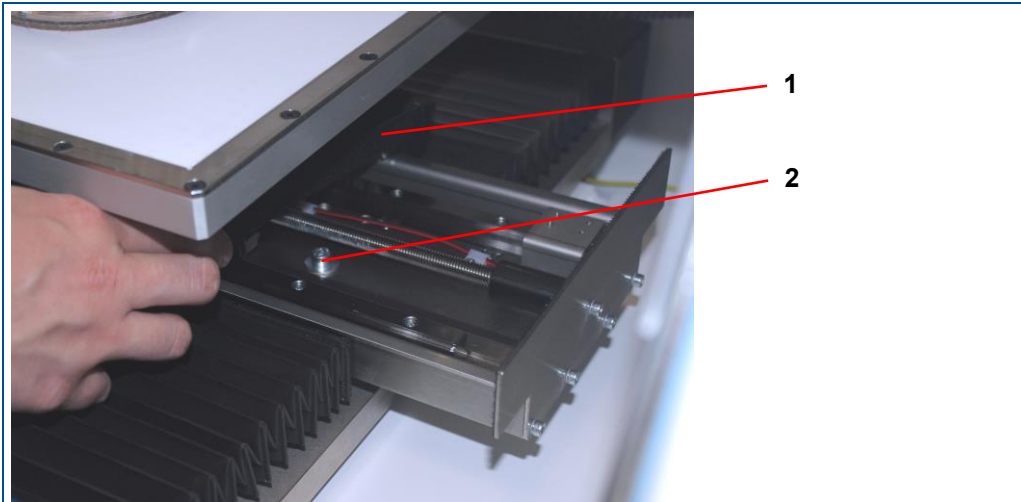


Fig. 44: x axis

1 Bellows of x axis, right side

2 Bolt

3. Pull out the bolt.



Fig. 45: Pulling out the bolt

4. Repeat steps 2 and 3 on the left side of the x axis.
 5. Cover the mounting hole with the bellows.
- The transport locks of the x/y table have been removed.



Store the transport brackets in a dry place in immediate vicinity of the system. Reinsert the bolts for securing the x/y table every time the system has to be transported.

5.3.2 Filling the coolant

The chiller is located behind the front cover.

The coolant additive (Glysantin) that has been delivered in a separate container has to be mixed with distilled water and filled into the chiller before the system is operated.

The mixing ratio is: 1:6 (Glysantin/distilled water).

Ensure that the following prerequisites are fulfilled before performing the described tasks:

Prerequisites

- Wear a respirator mask with gas filter for organic gases/vapors
- Wear safety glasses with side shields
- Wear chemical-resistant gloves

Spare parts and auxiliaries

- Control cabinet key
- Jerry can with spout
- Glysantin
- Distilled water

- ▶ Always read the safety data sheets before working with hazardous substances and chemicals and always observe the instructions given therein.

■ Pouring in the coolant

1. Pull on the lower left edge of the maintenance door to open it.



Fig. 46: Opening the maintenance door

2. Remove the cap of the filler neck (1).

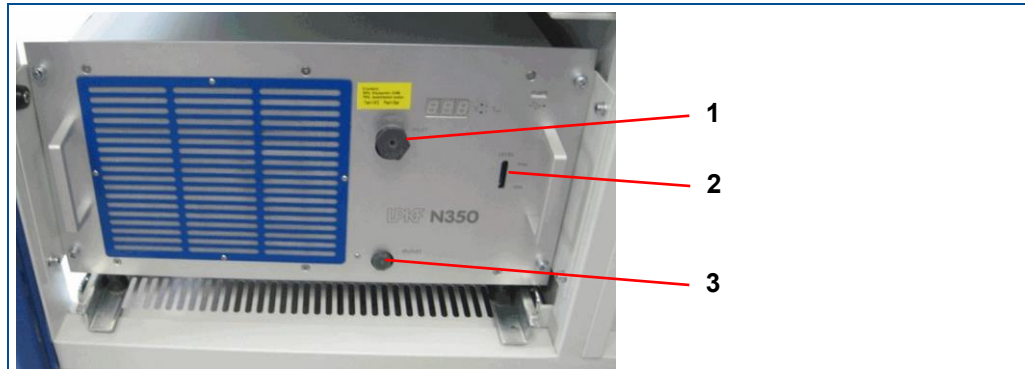


Fig. 47: Chiller

- | | | | |
|---|----------------------|---|-------------|
| 1 | Filler neck | 3 | Drain valve |
| 2 | Fill level indicator | | |

WARNING! Health hazard by contact with chemicals!

► **Wear safety glasses with side shields and chemical-resistant gloves.**

3. Fill the jerry can contained in the delivery with 0.7 l Glysantin and 4.3 l distilled water.
 4. Use the spout to fill the resulting coolant into the filler neck (1).
 5. Fill coolant into the chiller until the fill level indicator (2) displays a maximum fill level.
 6. Screw the cap back onto the filler neck.
 7. Close the maintenance door.
 8. Store unused coolant according to the information in the safety data sheet.
- The coolant has been poured in.

5.3.3 Checking the local mains voltage of the chiller

Ensure that the mains voltage of the chiller is set to the local mains voltage (110 V / 230 V) before connecting the system to the mains power supply.

The chiller is preset to a mains voltage of 230 V on delivery. If your local mains voltage is 110 V, change the local mains voltage setting of the chiller.

Ensure that the following prerequisites are fulfilled before performing the described tasks:

Prerequisites

- Mains cable of the system is not connected.

Spare parts and auxiliaries

- Control cabinet key
- Flat-bladed screwdriver

■ Changing the local mains voltage setting of the chiller

1. Insert the control cabinet key into the keyhole of the rear cover.
2. Turn the control cabinet key counter-clockwise by **180°**.

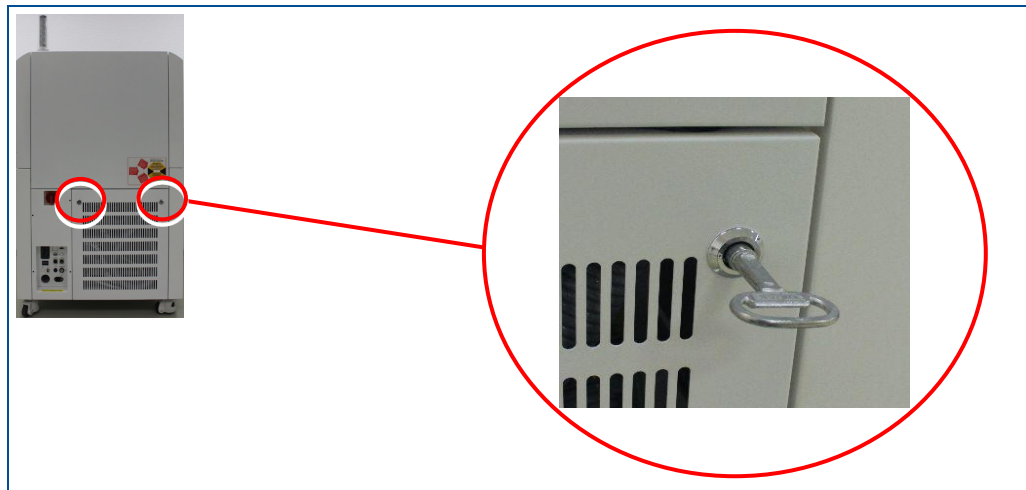


Fig. 48: Rear cover

3. Repeat steps 1 and 2 with the second keyhole of the rear cover.
4. Tilt the rear cover slightly forward and disconnect the grounding cable.



Fig. 49: Grounding cable

5. Lift the rear cover upwards.

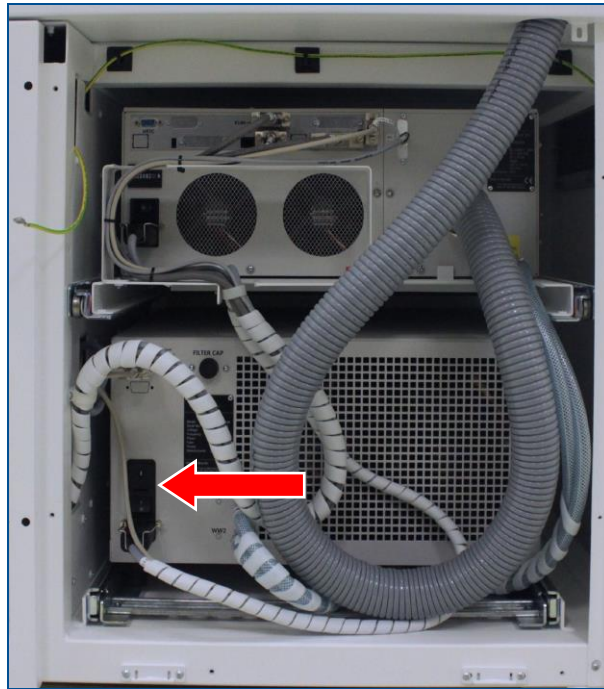


Fig. 50: Line filter of the chiller

6. Pry out the line filter using a flat-bladed screwdriver.
 7. Turn the line filter by **180°** and reinsert it.
 8. Reassemble the mentioned components in reverse order.
- The local mains voltage setting of the chiller has been changed.

5.4 Connecting the system

Once the preparations are concluded, the system is connected in the following order:

- Connecting the stack light
- Connecting the extraction system
- Connecting the compressed-air supply
- Connecting to the network
- Connecting the screen, keyboard, and mouse
- Connecting the system to the mains power supply

5.4.1 Connecting the stack light

Connect the stack light with the system and install it subsequently.

Material



■ Connecting the stack light

1. Connect the cable of the system with the connector of the stack light:

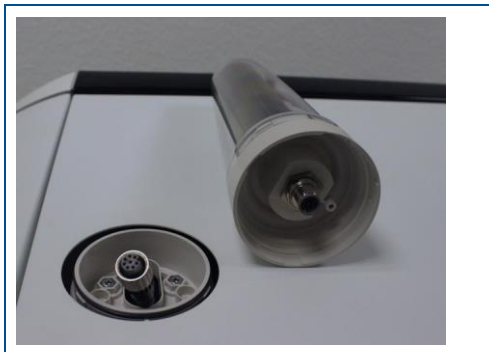


Fig. 51: Connecting the cable

2. Insert the stack light into the socket.
The markings of the stack light and of the socket must match up.

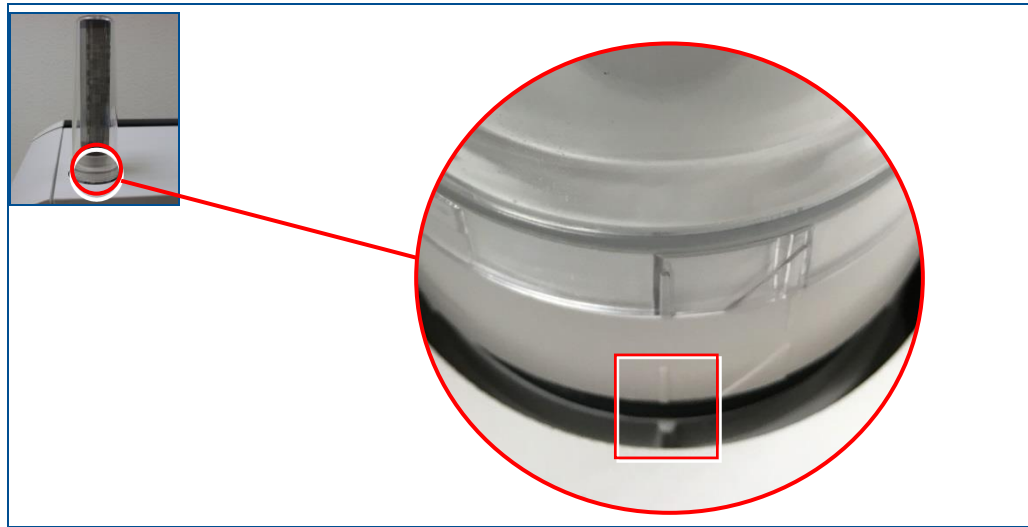


Fig. 52: Stack light markings

3. Fasten the stack light by turning it clockwise.

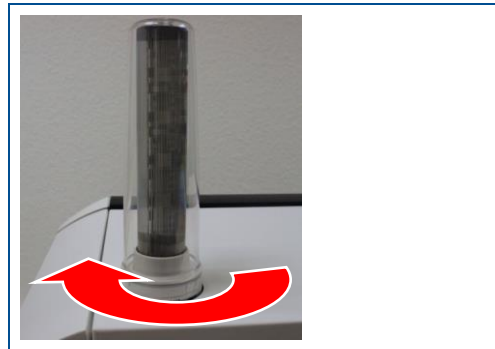


Fig. 53: Turning the stack light

- The stack light has been connected.

5.4.2 Connecting the extraction system

The extraction system is an optional accessory that can be ordered from LPKF. The following shows the required steps for connecting the TEKA-LMD 508 and the prefilter unit:

Material



■ Connecting the extraction system

1. Connect the extraction hose of the extraction system with the prefilter unit.

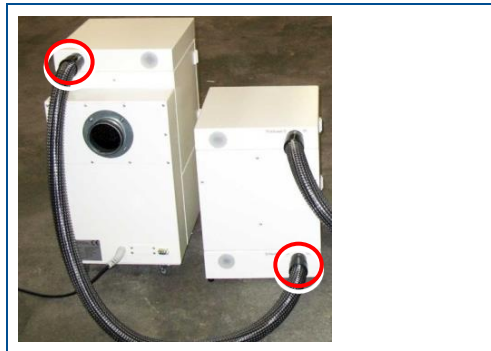


Fig. 54: Extraction system with prefilter unit

2. Connect the extraction hose of the prefilter unit with the system.

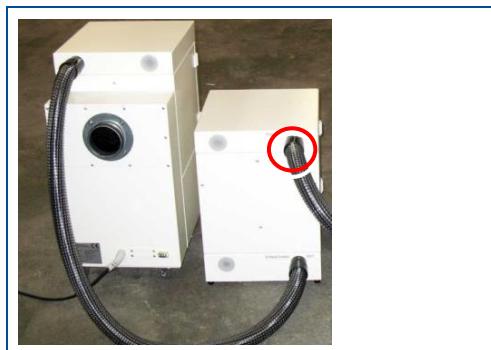


Fig. 55: Connector for extraction system



3. Connect the female 9-pin D-sub connector with the system.



Fig. 56: Connector for the control cable

4. Connect the male 9-pin D-sub connector with the extraction system.



Fig. 57: Connector for the control cable

5. Connect the air outlet nozzle with your exhaust system.



Fig. 58: Air outlet nozzle

6. Connect the extraction system to the mains power supply.



Fig. 59: Wall socket

- The extraction system has been connected.



LPKF recommends to set the rotation speed of the extraction system to 70%. Adjust the stop delay of the extraction system according to your needs. For further information refer to the user manual of the extraction system.

5.4.3 Connecting the compressed-air supply

The system is connected to the compressed-air supply via a pneumatic tube.

Material



■ Connecting the compressed-air supply

1. Connect the pneumatic tube with the compressed-air connector (coupling for 8 mm outer tube diameter) of the system.



Fig. 60: Connector for compressed-air tube

2. Connect the pneumatic tube with the compressed-air supply (maximum pressure: 8 bar).
- The compressed-air supply has been connected.

5.4.4 Connecting to the network

The system is connected to the network via a network cable.

Material



■ Connecting the network cable

1. Connect the network cable to the system.



Fig. 61: Connecting the network cable

2. Connect the network cable to your network.



Fig. 62: Network connector

- The network cable has been connected.

5.4.5 Connecting the screen, keyboard, and mouse

The screen is connected to the system via a USB cable. The keyboard and mouse are connected to the screen via a USB cable.

Material



■ Connecting the screen, keyboard, and mouse

1. Connect the DisplayPort cable to the system.



Fig. 63: DisplayPort connector

2. Connect the DisplayPort cable to the screen.



Fig. 64: DisplayPort at bottom of screen

3. Connect the USB cable to the system.



Fig. 65: USB port

4. Connect the USB cable to the screen.



Fig. 66: USB port at bottom of screen

5. Connect the USB cable of the keyboard and the mouse to the screen.



Fig. 67: USB port at bottom of screen

6. Connect the mains cable to the screen.



Fig. 68: Connector for mains cable at bottom of screen

7. Plug the mains cable into the wall socket.



Fig. 69: Mains cable

The screen, keyboard, and mouse are connected.

5.4.6 Connecting the system to the mains power supply

The System is connected to the mains power supply via a mains cable.

Material



■ Connecting the mains cable

1. Connect the mains cable to the system.



Fig. 70: Connector for mains cable

2. Plug the mains cable into the wall socket.



Fig. 71: Wall socket

- The mains cable has been connected.

5.4.7 Switching on the system with the main switch

The main switch of the system switches on or off the mains power supply.

■ Switching on the system with the main switch

1. Turn the main switch at the rear of the system to position *I ON*.



Fig. 72: Main switch set to *I ON*

- The mains power supply of the system is switched on.

6 Operating the system

This chapter contains important information on operating the system and the associated software programs.



For detailed information on operating the system software press **F1** to invoke the help function.

6.1 Safety

WARNING

Risk of injury by laser radiation!

As soon as the system is switched into the service mode, the system is classified as laser class 4.

- ▶ Always wear the personal protective equipment.
- ▶ Never look directly into the laser beam.

WARNING

Health hazard by gases or dusts!

Processing materials with laser beams can produce gases or dusts hazardous to health.

- ▶ Only process materials that are approved by LPKF.
- ▶ Always ensure that the extraction system is switched on and working properly.

NOTICE

Property damage by items in the processing area!

When the system is switched on items in the processing area can cause property damage.

- ▶ Before switching on the system, always ensure that no items and no parts are in the processing area.

6.1.1 Switching off the system in an emergency

The emergency stop button switches off the laser immediately and stops the motorized axes. This stop is only intended for an emergency.

Stopping the system in an emergency

- ▶ Push the emergency stop button (see chapter 1.9).
- The power supply of the laser is switched off and the drives are de-energized.
- The system has been stopped in an emergency.

6.1.2 Restarting the system after an emergency stop

After pushing the emergency stop button you have to switch on the system properly to continue the production.

■ Restarting the system after an emergency

1. Unlock the emergency stop button by turning it.
 2. Acknowledge the faults in the fault monitor.
 3. Press the button *ACK* at the system front.
- The system is switched on after an emergency and the x/y table is referenced again.

6.2 Preparations for use

Before working with the system check the following settings and conditions:

- The requirements of the place of installation (see chapter 5.2) have to be met.



If a cold system is brought into a warm environment this can cause condensation of the humidity. Thus, let the system that has been disconnected from the power supply acclimatize **for 24 hours** before you connect it to the power supply again.

- The following components have to be connected to the system and have to be ready for operation or switched on:
 - Pneumatic connection
 - Extraction system
 - Screen, keyboard, mouse
 - Power supply



Operate the system connected to an overcurrent protection device (230 V / 16 A / 110 V).

- Check if the safety devices described on page 25 function properly.

6.3 Typical production process

This chapter describes a typical production process. The following steps are performed:

- Switching on the system
- Importing the data
- Inserting fiducials
- Computing toolpaths and scan fields automatically
- Configuring a toolpath manually (optional)
- Computing scan fields manually (optional)
- Processing a PCB
- Stopping processing (optional)
- Switching off the system
- Cleaning the system

■ Switching on the system

1. Press the on/off button at the system front.
- The system is switched on. The PC starts automatically.
2. Double-click on the desktop icon of CircuitPro PL 3.0.



Fig. 73: Desktop icon CircuitPro PL

- The following dialog is displayed:

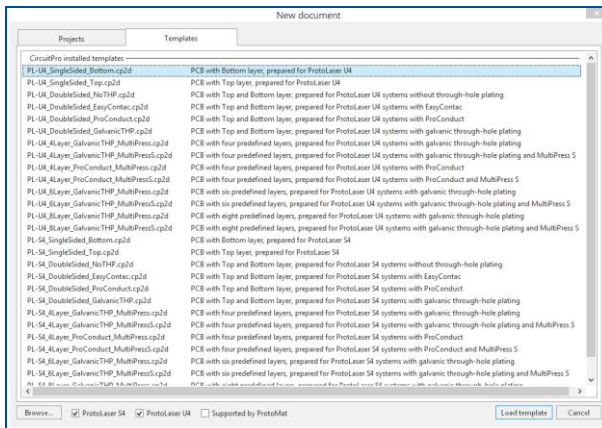


Fig. 74: Dialog New document

3. Select the template *PLU4_doublesided_NoTHP.cp2d*.
4. Click on [Load template].

- The following dialog is displayed:

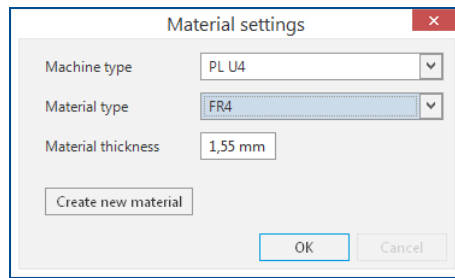


Fig. 75: Dialog *Material settings*

5. Select the *Machine type* and the *Material type*.
6. Enter the *Material thickness*.
7. Click on [OK].

- The user interface of CircuitPro PL is displayed:

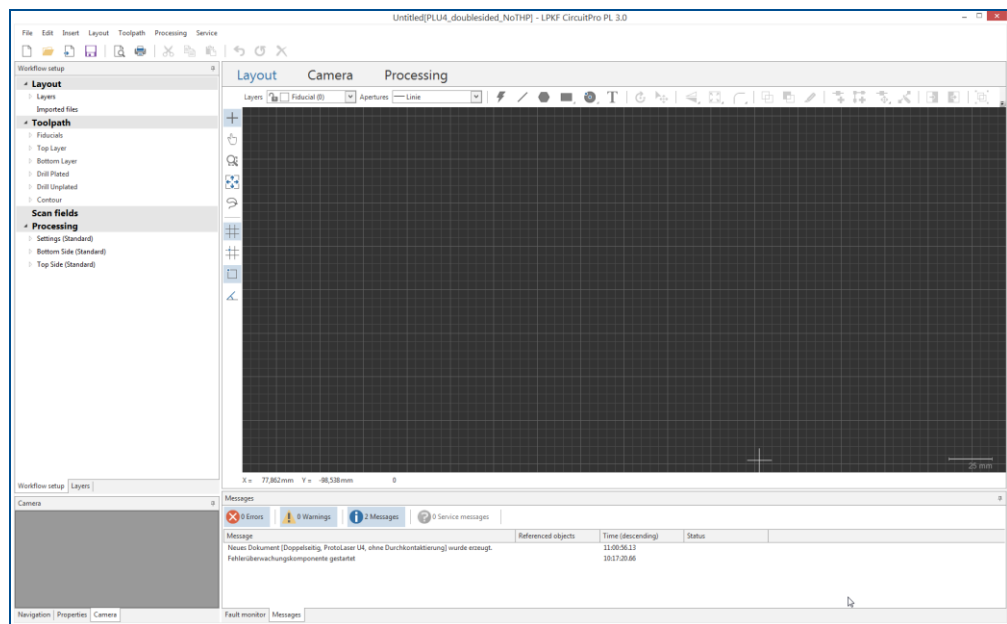


Fig. 76: User interface CircuitPro PL

- The system software recognizes the connected system automatically, establishes the connection and the following message is displayed:

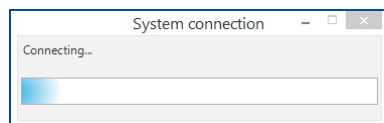


Fig. 77: Message *System connection*

- The following dialog is displayed:

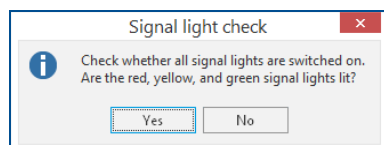


Fig. 78: Dialog *Checking signal lights*

8. If all lamps of the stack light are lit, click on [Yes].
- The system has been switched on.




Connecting the system manually

If automatic connection of the system fails, you can connect the system manually with the system software:


- ▶ Click on *Production* > *Connect with machine...*
- ▶ Select your system in the drop-down list.
- ▶ Click on [Connect].



The system requires a warm-up time of approx. **20** minutes for the laser source to attain a constant diode temperature. The warm-up phase starts automatically with the processing of the first job.

Alternatively, you can start the warm-up phase manually. In the *Production* view, click on . You can continue working in the *CAM* view during the warm-up phase.

Importing the data

1. Click on *File* > *Import* or on .
- The following dialog is displayed:

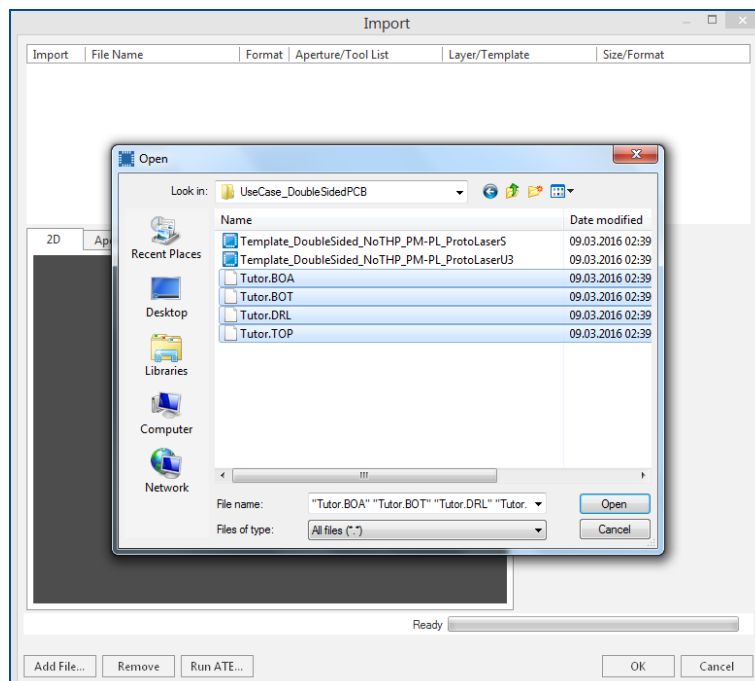


Fig. 79: Dialog *Import*

2. Navigate to the folder `C:\Users\User name\Documents\LPKF Laser & Electronics\LPKF CircuitPro PL 3.0\Example Data\UseCase_DoubleSidedPCB` and select the files *Tutor.BOA*, *Tutor.BOT*, *Tutor.DRL* and *Tutor.TOP*.
3. Click on [Open].

- The data are automatically assigned to the correct layers and the following dialog is displayed:

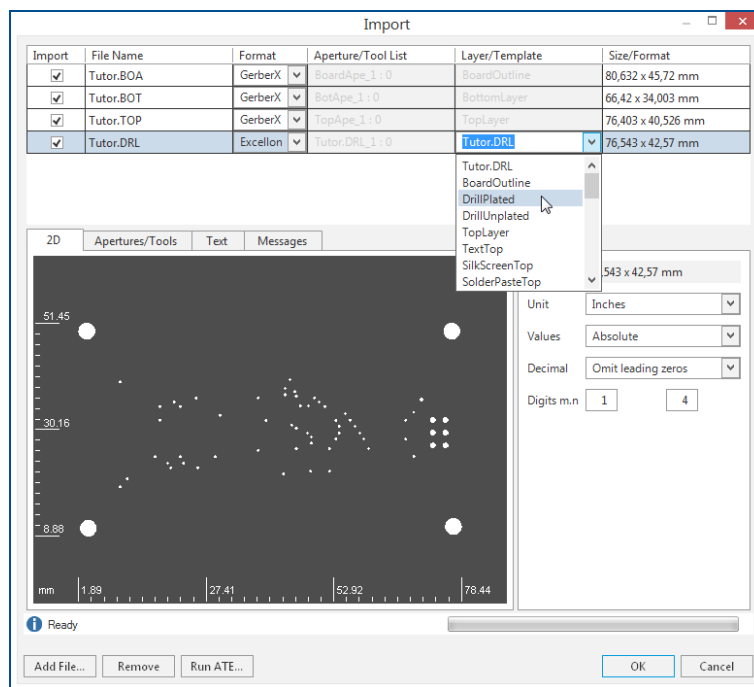


Fig. 80: Assign layer

- In the column *Layer/Template* select the layer *DrillPlated*.
 - Click on [OK].
- The CAM view changes as follows:

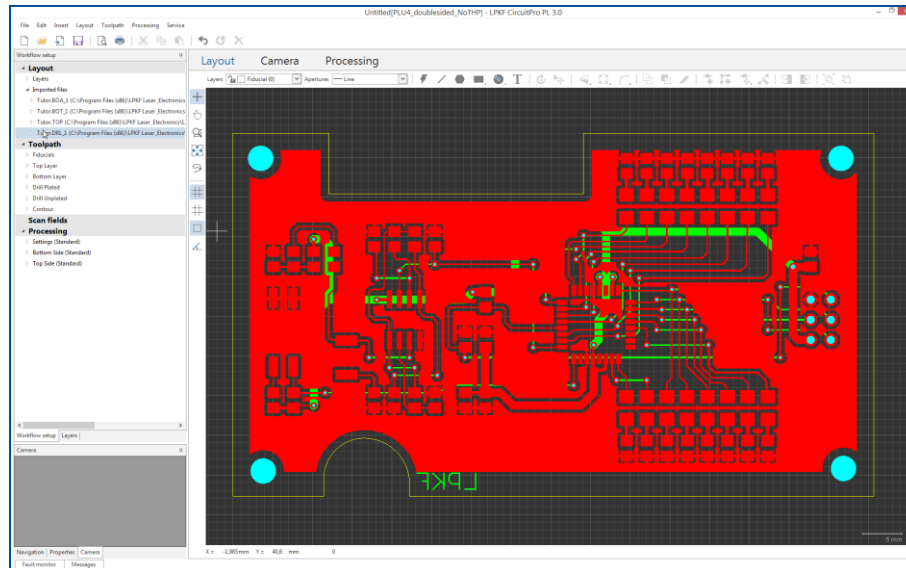


Fig. 81: Imported data in the CAM view

- ☑ The data have been imported.

■ Inserting fiducials

1. Click on *Insert > Fiducial > Fiducial*.
2. Insert four fiducials.

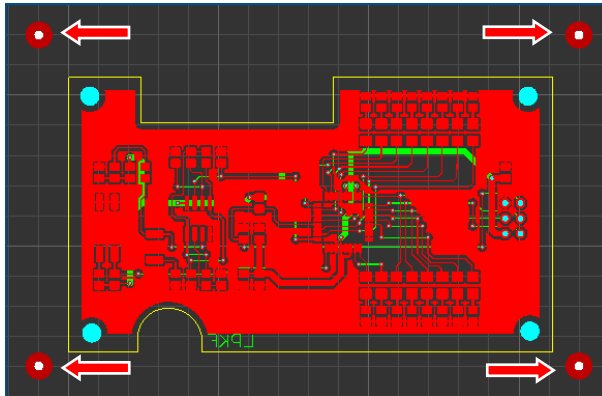


Fig. 82: Inserting fiducials

3. Press `[ESC]`.
 - The function is closed.
 - The fiducials have been inserted.

■ Computing toolpaths and scan fields automatically

1. In the pane *Workflow setup* right-click on the section *Toolpaths*.
 - The following context menu is displayed:

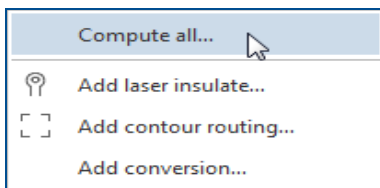


Fig. 83: Context menu

2. Click on the menu item *Compute all...*
 - The scan fields and toolpaths are computed automatically with default settings and the following message is displayed:

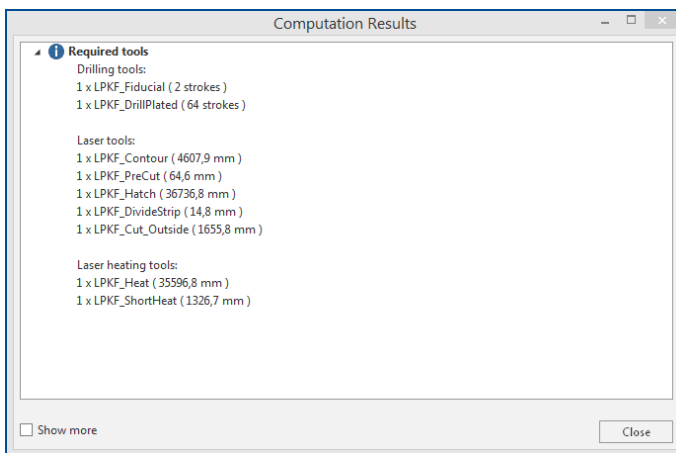


Fig. 84: Message *Computation results*

3. Click on `[Close]`.
 - The toolpaths have been computed.



If you do not want to compute the toolpaths and scan fields with the default settings, you can adapt the settings to your needs (see *Configuring toolpaths manually* and *Computing scan fields manually*).

■ **Configuring toolpaths manually**

1. In the pane *Workflow setup* right-click in the *Toolpaths* section on *Fiducials*.
- The following context menu is displayed:

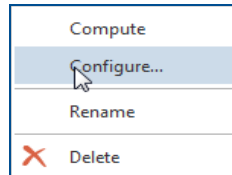


Fig. 85: Context menu

2. Click on the menu item *Configure...*
- The following dialog is displayed:

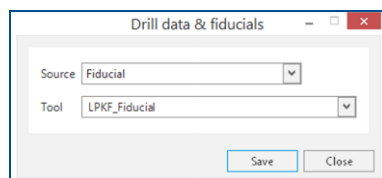


Fig. 86: Dialog *Drill data & fiducials*

3. Adapt the settings if necessary.
 4. Click on [Save].
 5. In the pane *Workflow setup* right-click in the *Toolpaths* section on *Top Layer*.
- The context menu is displayed.
6. Click on the menu item *Configure...*

- The following dialog is displayed:

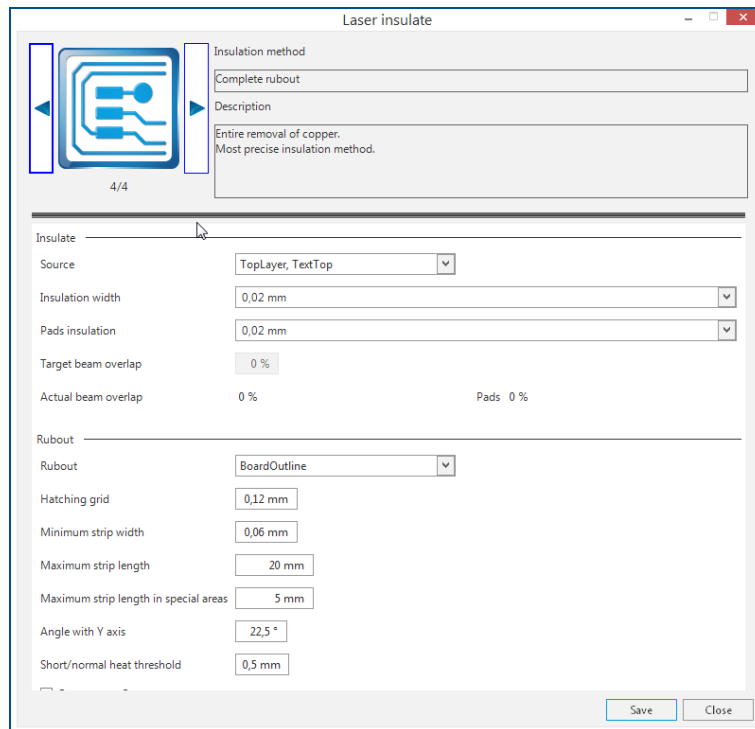


Fig. 87: Dialog Laser insulate

7. Adapt the settings if necessary.
8. Click on [Save].
9. In the pane *Workflow setup* right-click in the *Toolpaths* section on *Bottom Layer*.
- The context menu is displayed.
10. Click on the menu item *Configure...*
- The dialog *Laser insulate* is displayed.
11. Adapt the settings if necessary.
12. Click on [Save].
13. In the pane *Workflow setup* right-click in the *Toolpaths* section on *Drill Plated*.
- The context menu is displayed.
14. Click on the menu item *Configure...*
- The following dialog is displayed:

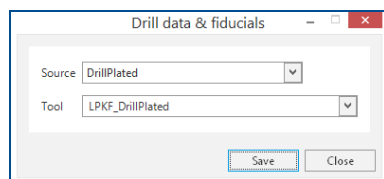


Fig. 88: Dialog Laser insulate

15. Adapt the settings if necessary.
16. Click on [Save].
17. In the pane *Workflow setup* right-click in the *Toolpaths* section on *Drill Unplated*.
The toolpath *Drill Unplated* is not used for this PCB and can be deleted.
- The context menu is displayed.
18. Click on the menu item *Delete*.
- The unused toolpath *Drill Unplated* is deleted.
19. In the pane *Workflow setup* right-click in the *Toolpaths* section on *Contour*.

- The context menu is displayed.
- 20. Click on the menu item *Configure...*
- The following dialog is displayed:

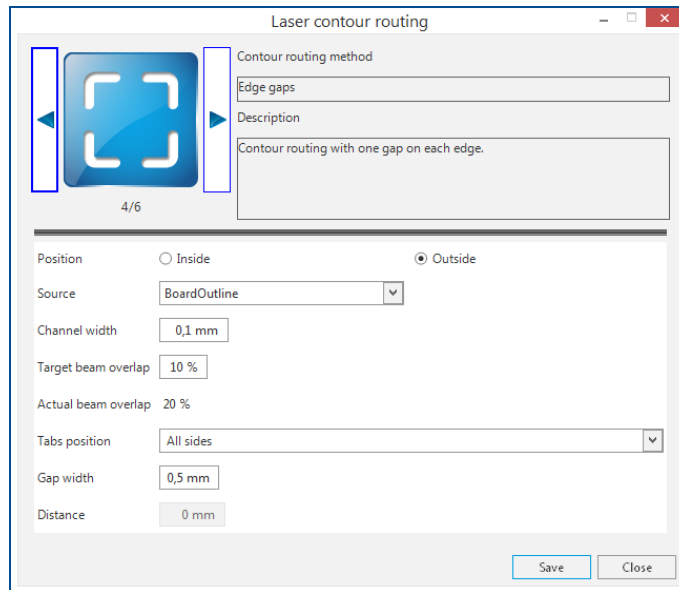


Fig. 89: Dialog *Laser contour routing*

- 21. Adapt the settings, if necessary.
- 22. Click on [Save].
- The toolpaths have been configured.

■ Computing scan fields manually

1. In the pane *Workflow setup* right-click in the *Production* section on *Bottom Side (Standard)*.
- The following context menu is displayed:

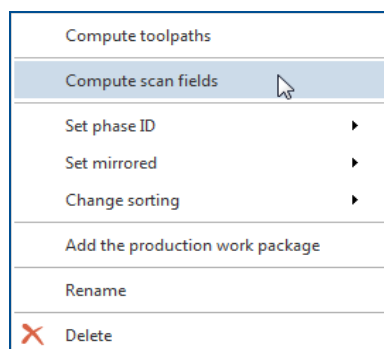


Fig. 90: Context menu

2. Click on the menu item *Compute scan fields*.

- The following dialog is displayed:

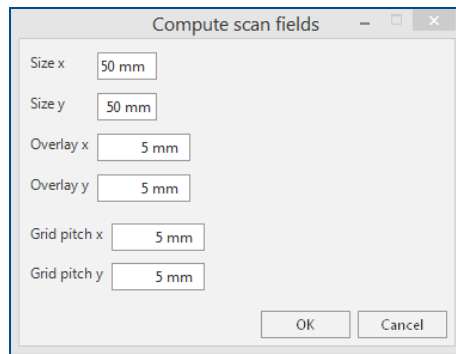


Fig. 91: Dialog *Compute scan fields*

3. Adapt the settings, if necessary.
4. Click on [OK].

- The CAM view changes as follows:

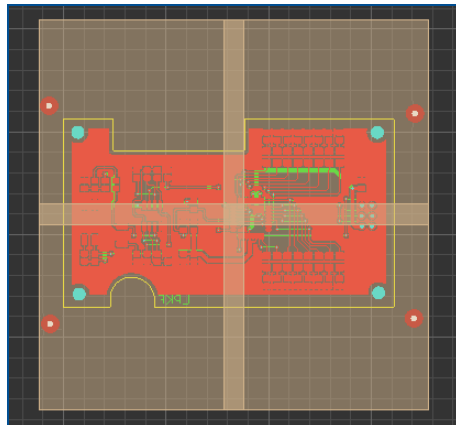


Fig. 92: Scan field Bottom Side

5. In the pane *Workflow setup* right-click in the *Production* section on *Top Side (Standard)*.

- The following context menu is displayed:

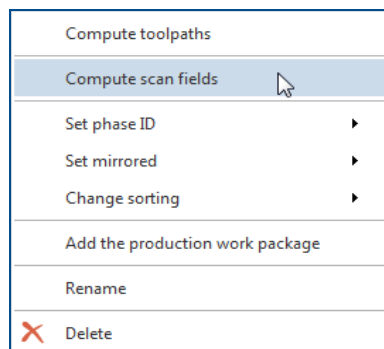


Fig. 93: Context menu

6. Click on the menu item *Compute scan fields*.

- The following dialog is displayed:

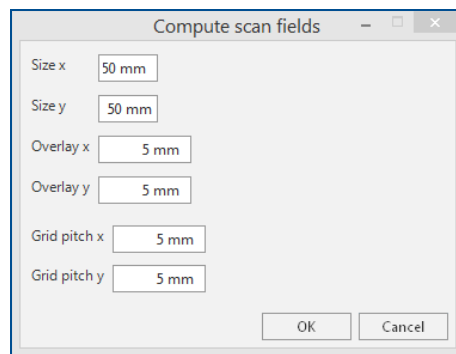


Fig. 94: Dialog *Compute scan fields*

- Adapt the settings, if necessary.
- Click on [OK].

- The CAM view changes as follows:

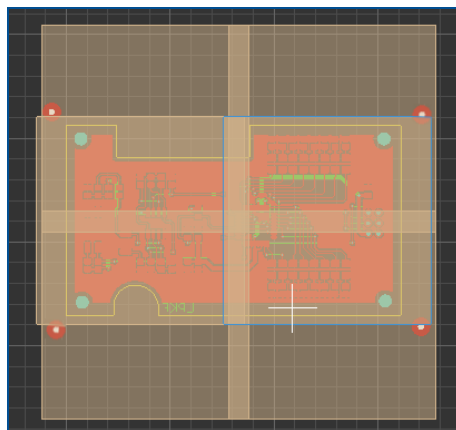


Fig. 95: Scan field Bottom Side + Top Side

- The scan fields have been computed.

■ Processing a PCB

1. Measure the thickness of the material with a calliper gauge.



Clean the material surface with a micro etchant (e.g. ViaCleaner) if a discoloration (oxide layer) is discernible. Thus, a surface is achieved that always has the same characteristics.

2. Click on *Processing > Process all* or in the *Production* view on

The following messages are displayed:

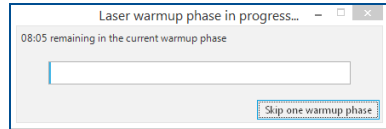


Fig. 96: Message *Laser warm up phase in progress...*

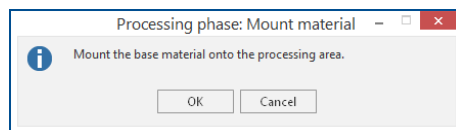


Fig. 97: Message *Processing phase: Mount material*

3. Open the cover.

4. Place the base material onto the x/y table.

5. In the *Production* view, click on

The base material is affixed to the x/y table.

6. Close the cover.

7. Click on [OK].

The following dialog is displayed:

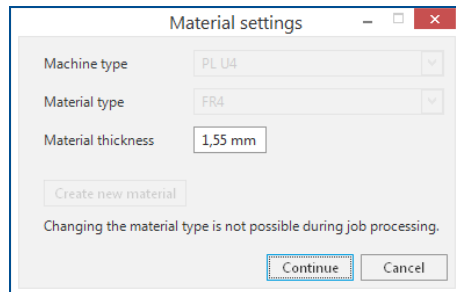


Fig. 98: Dialog *Material settings*

8. Enter the measured value in the field *Material thickness*.

9. Click on [Continue].

The following dialog is displayed:

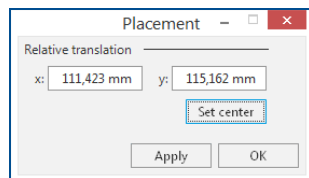


Fig. 99: Dialog *Placement*

10. Place the processing data.

The production data can be moved using drag & drop or by entering the values in the fields x and y. Click on [Set center] to place the processing data at the center of the base material.

11. Click on [Continue].

- The structuring is started and the following message is displayed:

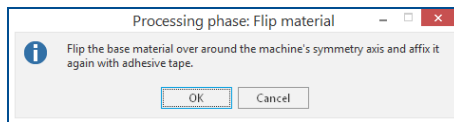


Fig. 100: Message *Processing phase: Turn material over*

12. Turn the base material over around the symmetry axis of the system.
13. Fasten the material along its edges with adhesive tape.
14. Click on [OK].
15. If the fiducials are not found automatically, the following message is displayed:

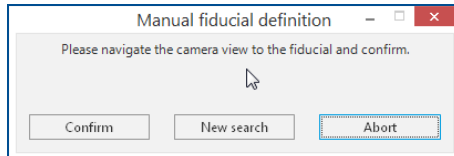


Fig. 101: Message *Manual fiducial definition*

16. Switch to the *Camera* view.
 17. Move the camera image to the position of the fiducial and click on [Confirm].
- The structuring is started and the following message is displayed:

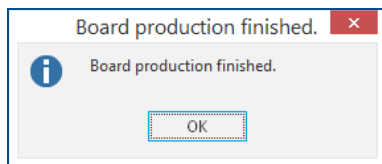


Fig. 102: Message *Board production finished*

- The PCB has been processed.

■ Stopping processing

1. Click on *Processing > Stop processing*.
Alternatively, click on ■.
- Processing has been stopped.

■ Switching off the system

1. Click on *File > Exit*.
- The connection to the system is disconnected and the system software is closed.
2. Perform one of the following steps:
 - In the Windows user interface, click on *Start > Shut down*.
 - Press the *On/Off button* at the system front briefly.
- The operating system is shut down.
 - The system has been switched off.

■ Cleaning the system

The processing area has to be cleaned if heavily soiled.

- ▶ Use a vacuum cleaner to remove chips and residues from the processing area.

6.4 Special tasks

This chapter describes rarely used tasks that may facilitate working with your system. The following steps are performed:

- Switching off the system with the main switch
- Replacing the sinter plate

■ Switching off the system with the main switch

1. Turn the main switch at the rear of the system to position *0 OFF*.



Fig. 103: Main switch set to *0 OFF*


- The mains power supply of the system is switched off.

■ Replacing the sinter plate

If the sinter plate has become unusable due to wear or burns, it has to be replaced.

Ensure that the following spare parts and auxiliaries are available before performing the described tasks:

Spare parts and auxiliaries

- Sinter plate (order code: 10055362)
1. In the *Production* view, click on .
- The system moves to the loading position.
2. Open the cover.
 3. Remove the sinter plate.
 4. Clean the x/y table, if necessary.
 5. Insert the new sinter plate.
 6. Close the cover.
- The sinter plate has been replaced.

7 Maintenance

This chapter contains important information about maintenance of the system.

Proper maintenance and the proper operation of the corresponding supply units such as the extraction system and the compressed-air supply are basic requirements for a smooth function of the system.

According to the manufacturer, maintenance should be executed and documented on a regular basis.

Each maintenance task and each service has to be recorded in the logbook with date, operating hours, as well as the tasks that have been executed.

The system is designed for a service life of 10 years used in one-shift operation (8 hours a day). The specified maintenance intervals are valid for one-shift operation at 5 days a week.

7.1 Safety

Follow the safety instructions below for your own protection and for the protection of other persons in the vicinity of the maintenance work. The maintenance personnel must ensure that the described prerequisites for the planned maintenance tasks are fulfilled and they must observe the special warning messages for the individual maintenance tasks.

DANGER

Danger to life by missing safety devices!

Missing or deactivated safety devices while operating the system can cause serious injuries or even death.

- ▶ Always ensure that all safety devices are functioning properly and are switched on.

DANGER

Danger to life by electrical shock!

Any physical contact to energized components or cables can cause death by electrical shock and/or fire.

- ▶ Switch off the system with the main switch before starting any maintenance work.
- ▶ Disconnect the external components from the power supply.
- ▶ Secure the system and the components against unintended restart.

For maintenance tasks wear your personal protective equipment (see chapter 1.7).

7.2 Maintenance schedules

The following tables provide an overview of the maintenance tasks that have to be performed by properly trained personnel.

7.2.1 Maintenance schedule for the maintenance personnel of the operator

The operating hours counter is at the rear of the system (see chapter 3.7).

Component/Assembly	Interval	Task to be performed	Remark
Protection glass of the processing head	Weekly	Visual check	see page 105
Extraction hood	Weekly	Visual check	see page 107
Coolant filter	After 250 operating hours or at least once every three months	Clean	see page 108
Air filter of the laser control	After 250 operating hours or at least once every three months	Clean, replace if damaged	see page 110
Air filter of the chiller	After 500 operating hours or at least once every six months	Clean, replace if damaged	see page 112
Protection glass of the processing head	After 1000 operating hours or at least once a year	Replace	see page 118
Drive spindle linear guides	After 1000 operating hours or at least once a year	Cleaning, lubricating	see page 114
Coolant	After 1000 operating hours or at least once a year	Replace	see page 116
Protection glass of the processing head	If required	Clean	see page 118
Extraction system LMD 508 Prefilter mat	In case of dropping extraction power or when replacing the particle filter.	Replace	Refer to the user manual of the manufacturer.
Extraction system LMD 508 Particle filter	Daily visual check of the dust indicator of the filter. Replace in case of dropping extraction power.	Visual check, replace	Refer to the user manual of the manufacturer.
Extraction system LMD 508 Activated carbon filter	Replace when replacing the particle filter or if gases escape on the clean air side.	Replace	Refer to the user manual of the manufacturer.
Compressor MONSUN Fast R	Refer to the user manual of the manufacturer.	Maintenance	Refer to the user manual of the manufacturer.

Table 18: Maintenance schedule for the maintenance personnel of the operator

7.2.2 Maintenance schedule for the LPKF Service

NOTICE			
Property damage by unauthorized use!			
Unauthorized use can cause damage to the system.			
▶ Maintenance and service tasks have to be performed by the LPKF Service.			

Component/Assembly	Interval	Task to be performed	Remark
Laser source	Every 2 years	Maintenance of the laser source by the LPKF Service	
Filter unit laser resonator	After 1000 operating hours or at least once a year	Maintenance of the filter unit by the LPKF Service	

Table 19: Maintenance schedule for the LPKF Service

7.3 Maintenance tasks for the maintenance personnel of the operator

This chapter contains a detailed description of the individual maintenance tasks that may only be performed by the maintenance personnel of the operator. For information on maintenance tasks of the extraction system refer to the manufacturer's user manual.

■ Checking the protection glass at the processing head visually

Ensure that the following prerequisites are fulfilled before performing the described tasks:

Prerequisites

- The system is switched off at the main switch and secured against restart

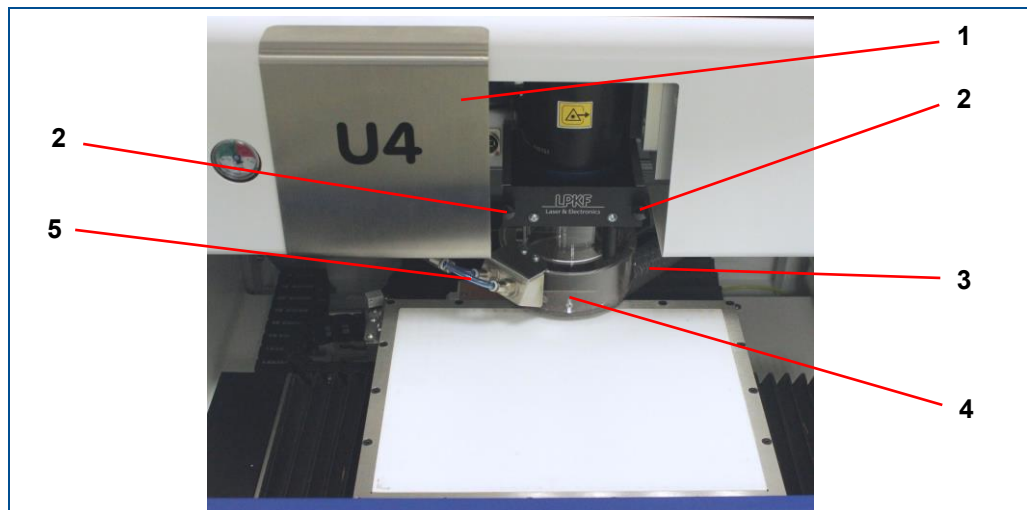


Fig. 104: System with open cover

- | | |
|--|-----------------------|
| 1 Maintenance cover in processing area | 4 Extraction hood |
| 2 Screw extraction hood | 5 Compressed-air tube |
| 3 Extraction hose | |

1. Open the cover.
2. Open the maintenance door in the processing area (1).
3. Disconnect the compressed-air tube (5) and the extraction hose (3) from the extraction hood (4).
4. Remove the screws (2) of the extraction hood.
5. Pull out the extraction hood towards you.
6. Pull out the lighting ring towards you.



Fig. 105: Lighting ring

7. Check the protection glass of the processing head for dirt and damage.

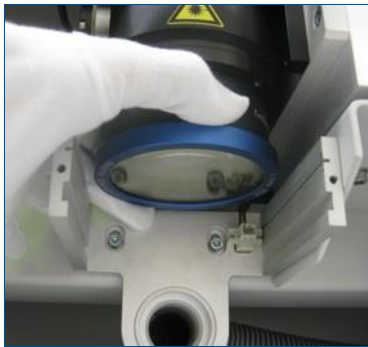


Fig. 106: Protection glass

8. Clean or replace the protection glass if it is dirty or damaged. For further information refer to page 118.
 9. Reassemble the mentioned components in reverse order.
- The protection glass at the processing head has been checked visually.

Visual check of the extraction hood

Ensure that the following prerequisites are fulfilled before performing the described tasks:

Prerequisites

- The system is switched off at the main switch and secured against restart

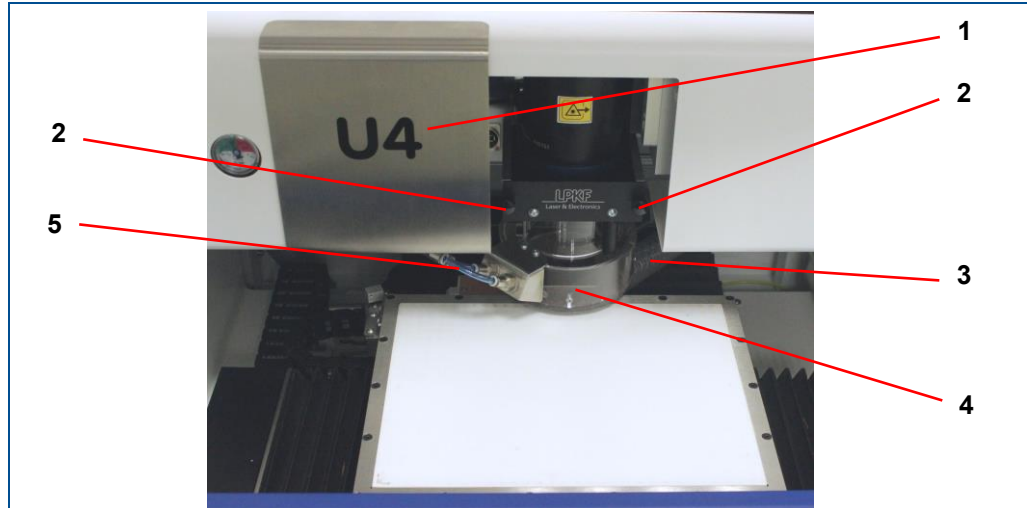


Fig. 107: System with open cover

- | | |
|--|-----------------------|
| 1 Maintenance cover in processing area | 4 Extraction hood |
| 2 Screw extraction hood | 5 Compressed-air tube |
| 3 Extraction hose | |

1. Open the cover.
 2. Open the maintenance door in the processing area (1).
 3. Disconnect the compressed-air tube (5) and the extraction hose (3) from the extraction hood (4).
 4. Remove the screws (2) of the extraction hood.
 5. Pull out the extraction hood towards you.
 6. Check the extraction hood for dirt.
 7. Clean the extraction hood if it is dirty.
 8. Reassemble the mentioned components in reverse order.
- The extraction hood has been checked visually.

Cleaning the coolant filter

Ensure that the following prerequisites are fulfilled before performing the described tasks:

Prerequisites

- The system is switched off at the main switch and secured against restart
- Wear safety glasses with side shields
- Wear chemical-resistant gloves

Spare parts and auxiliaries

- Control cabinet key
- Tweezers

▶ Always read the safety data sheets before working with hazardous substances and chemicals and always observe the instructions given therein.

1. Insert the control cabinet key into the keyhole of the rear cover.
2. Turn the control cabinet key counter-clockwise by 180°.

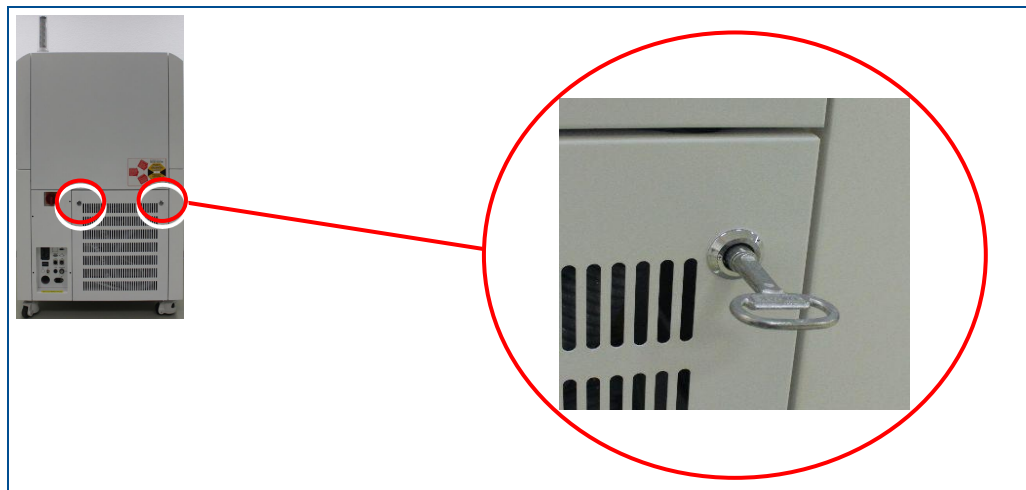


Fig. 108: Rear cover

3. Repeat steps 1 and 2 with the second keyhole of the rear cover.
4. Tilt the rear cover slightly forward and disconnect the grounding cable.

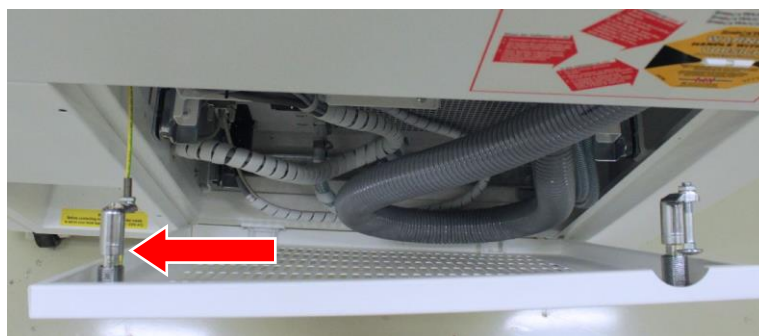


Fig. 109: Disconnecting the grounding cable

5. Lift the rear cover upwards.

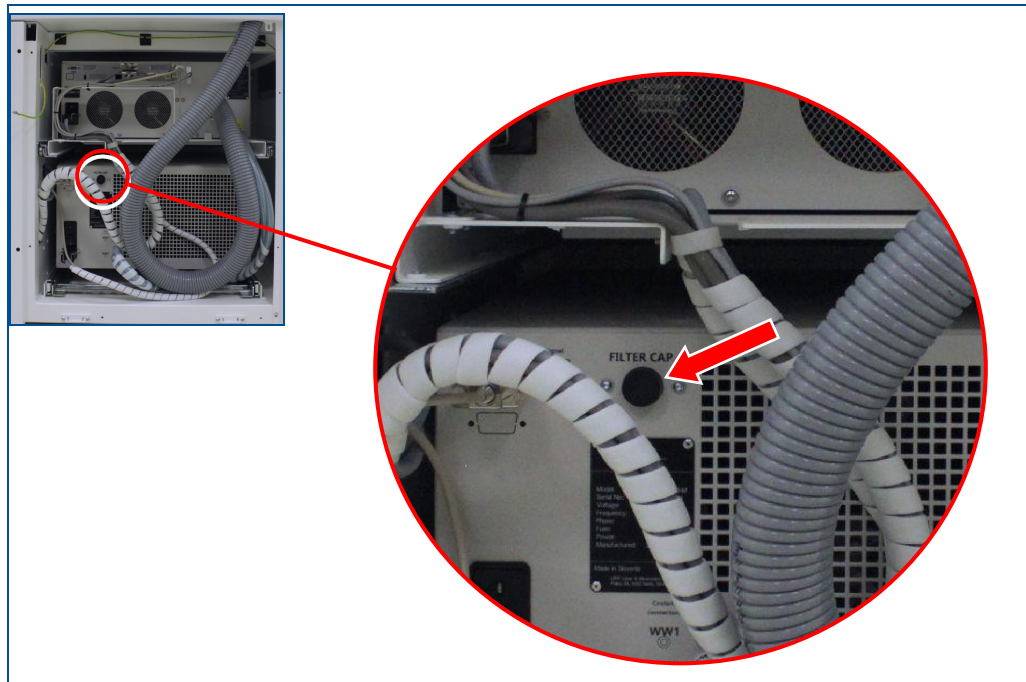


Fig. 110: System without rear cover

6. Remove the filter cap.

WARNING! Health hazard by contact with chemicals!

▶ **Wear safety glasses with side shields and chemical-resistant gloves.**

7. Use tweezers to pull out the coolant filter.

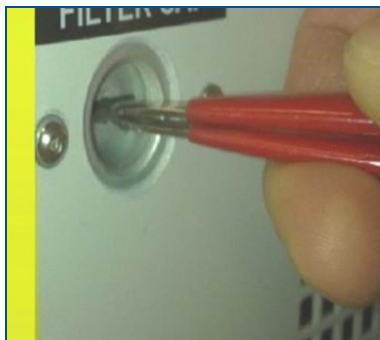


Fig. 111: Pulling out the coolant filter

8. Clean the coolant filter with running water.

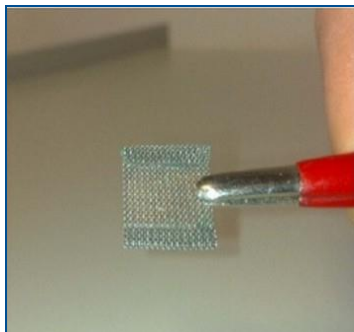


Fig. 112: Coolant filter

9. Reassemble the mentioned components in reverse order.

The coolant filter has been cleaned.



Repeat the cleaning of the coolant filter two or three times to remove all contaminants. Start the system between the cleaning procedures for approx. 5 minutes.

Cleaning the air filter of the laser control

Ensure that the following prerequisites are fulfilled before performing the described tasks:

Prerequisites

- The system is switched off at the main switch and secured against restart
- Wear protective glasses
- Wear a particle filter mask

Spare parts and auxiliaries

- Wrench
- Compressed air

1. Pull on the lower left edge of the maintenance door to open it.



Fig. 113: Opening the maintenance door

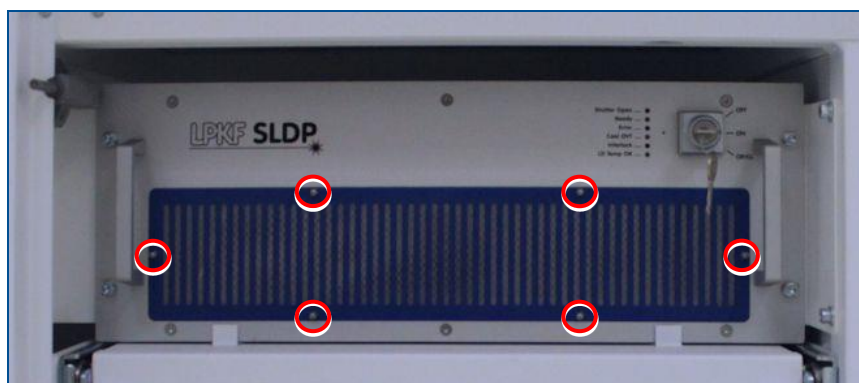


Fig. 114: Air filter

2. Remove the six cap nuts of the air filter.
3. Remove the air filter.

CAUTION! Risk of injury when blowing out the air filter!

▶ **Wear protective glasses and a particle filter mask.**

4. Blow out the rear of the air filter with compressed air (**6 bar max**).



Fig. 115: Blowing out the air filter



Replace the air filter if it is damaged or if the dirt cannot be fully removed.

5. Reassemble the mentioned components in reverse order.
 6. Close the maintenance door.
- The air filter has been cleaned.

Cleaning the air filter of the chiller

Ensure that the following prerequisites are fulfilled before performing the described tasks:

Prerequisites

- The system is switched off at the main switch and secured against restart
- Wear protective glasses
- Wear a particle filter mask

Spare parts and auxiliaries

- Wrench
- Compressed air

1. Pull on the lower left edge of the maintenance door to open it.



Fig. 116: Opening the maintenance door

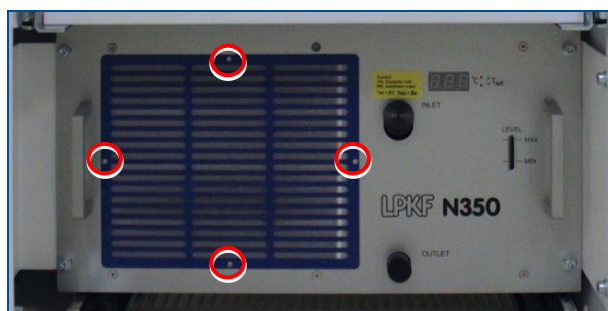


Fig. 117: Chiller

2. Remove the four screws of the air filter.
3. Remove the air filter.

CAUTION! Risk of injury when blowing out the air filter!
▶ **Wear protective glasses and a particle filter mask.**

4. Blow out the rear of the air filter with compressed air (**6 bar max**).

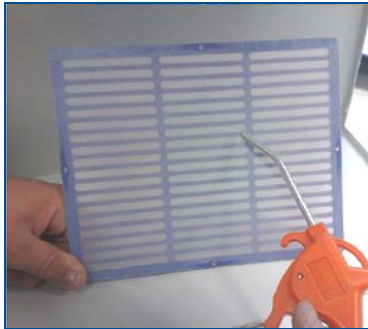


Fig. 118: Air filter



Replace the air filter if it is damaged or if the dirt cannot be fully removed.

5. Reassemble the mentioned components in reverse order.
 6. Close the maintenance door.
- The air filter has been cleaned.

Cleaning and lubricating the drive spindles and the linear guides

Ensure that the following prerequisites are fulfilled before performing the described tasks:

Prerequisites

- Wear latex lab gloves

Spare parts and auxiliaries

- Special ball bearing grease Dynalub 510
- Lubricant ISOFLEX TOPAS 5051
- Cotton cloth
- Wooden lab spatula

1. Move the x/y table to the right rear position.



For detailed information on operating the system software invoke the help function by pressing **F1**.

2. Open the cover.
3. Push the bellows (2) of the x axis to the right.

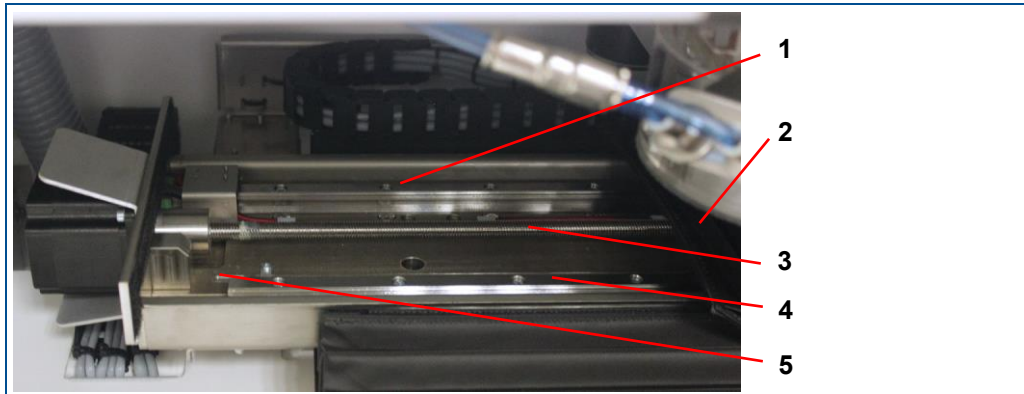


Fig. 119: x axis

- | | | | |
|---|-------------------|---|--------------|
| 1 | Linear guide | 4 | Linear guide |
| 2 | Bellows of x axis | 5 | Linear scale |
| 3 | Drive spindle | | |

NOTICE! System damage due to damage to the linear scales!

- ▶ **Ensure that no aggressive liquids and lubricants come into contact with the linear scales!**

4. Clean the drive spindle (3) and the linear guides (1, 4) with a cotton cloth.
5. Put some lubricating grease (**ISOFLEX TOPAS 5051**) on a wooden lab spatula.
6. Apply a thin lubricant film to the **drive spindle** using the wooden lab spatula; avoid overdosage.
7. Put some lubricating grease (**special ball bearing grease Dynalub 510**) on a wooden lab spatula.
8. Apply a thin lubricant film to the **linear guiding rails** using the wooden lab spatula, avoid overdosage.
9. Cover the opening with the bellows.

10. Push the bellows (2) of the y axis to the rear.

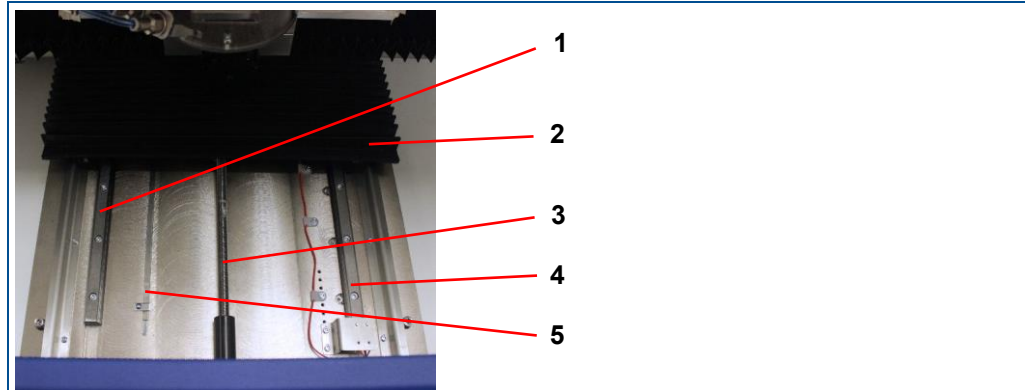


Fig. 120: y axis

- | | | | |
|---|-------------------|---|--------------|
| 1 | Linear guide | 4 | Linear guide |
| 2 | Bellows of y axis | 5 | Linear scale |
| 3 | Drive spindle | | |

11. Repeat the steps 4 - 8 on the y axis.

12. Cover the opening with the bellows.

13. Close the cover.

14. Move the x/y table to the left front position.

15. Open the cover.

16. Push the bellows of the x axis to the left.

17. Repeat steps 4 - 8.

18. Cover the opening with the bellows.

19. Push the bellows of the y axis to the rear.

20. Repeat the steps 4 - 8 on the y axis.

21. Cover the opening with the bellows.

The drive spindles and the linear guides have been cleaned and lubricated.

■ Replacing the coolant

Ensure that the following prerequisites are fulfilled before performing the described tasks:

Prerequisites

- The system is switched off at the main switch and secured against restart
- Wear a respirator mask with gas filter for organic gases/vapors
- Wear chemical-resistant gloves
- Wear protective glasses with side shields

Spare parts and auxiliaries

- Hex key 5 mm
- Coolant
The mixing ratio of the coolant is: 1:6 (Glysantin/distilled water).

▶ Always read the safety data sheets before working with hazardous substances and chemicals and always observe the instructions given therein.

1. Pull on the lower left edge of the maintenance door to open it.



Fig. 121: Opening the maintenance door

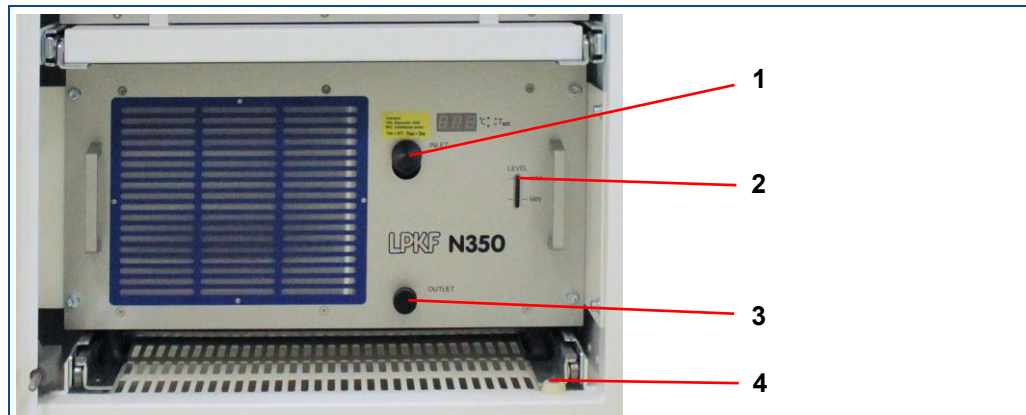


Fig. 122: Chiller

- | | | | |
|---|----------------------|---|---------------------------|
| 1 | Filler neck | 3 | Drain valve |
| 2 | Fill level indicator | 4 | Screw with rubber stopper |


2. Remove the screw with rubber stopper (4).
3. Cautiously pull the chiller out of the base frame until locked at full extension.
4. Place a suitable collection container under the drain valve (3) of the chiller.



Fig. 123: Coolant

WARNING! Health hazard by contact with chemicals!

- **Wear safety glasses with side shields and chemical-resistant gloves.**

5. Remove the cap of the drain valve.
 - The coolant flows into the collection container.
-  Dispose of the coolant according to your local environmental regulations.

6. Screw the cap back onto the drain valve.
7. Remove the cap of the filler neck (1).
8. Fill the jerry can contained in the delivery with 0.7 l Glysantin and 4.3 l distilled water.
9. Use the spout to fill the resulting coolant into the filler neck (1).
10. Fill coolant into the chiller until the fill level indicator (2) indicates a maximum fill level.
11. Screw the cap back onto the filler neck.

12. Reassemble the mentioned components in reverse order.
 13. Close the maintenance door.
 14. Store unused coolant according to the information in the safety data sheet.
- The coolant has been replaced.

Cleaning the protection glass of the processing head

Ensure that the following prerequisites are fulfilled before performing the described tasks:

Prerequisites

- The system is switched off at the main switch and secured against restart
- Ensure good ventilation/extraction at the workplace, otherwise wear a respirator mask.
- Wear protective gloves
- Wear safety glasses with side shields

Spare parts and auxiliaries

- Lens-cleaning tissue
- Isopropyl alcohol

- Always read the safety data sheets before working with hazardous substances and chemicals and always observe the instructions given therein.

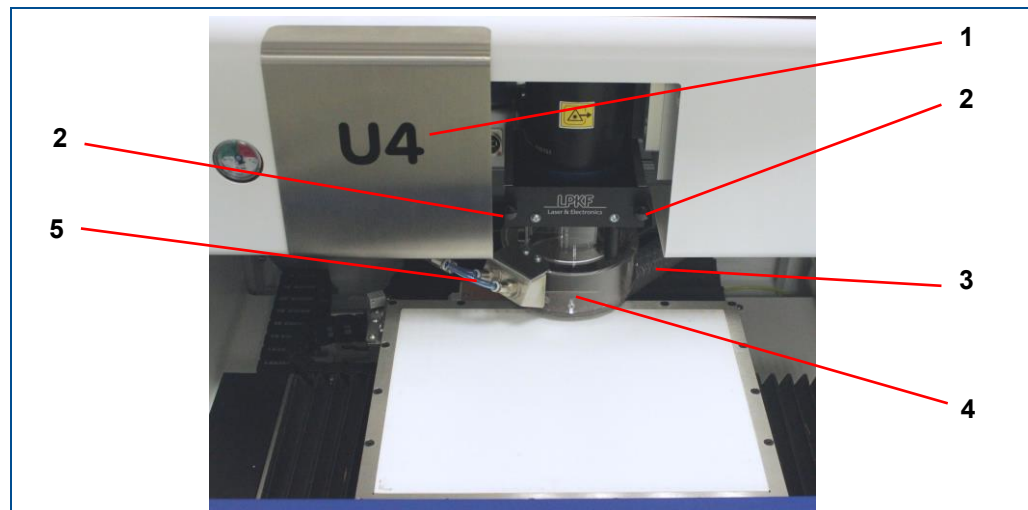


Fig. 124: System with open cover

- | | |
|--|-----------------------|
| 1 Maintenance cover in processing area | 4 Extraction hood |
| 2 Screw extraction hood | 5 Compressed-air tube |
| 3 Extraction hose | |

1. Open the cover.
2. Open the maintenance door in the processing area (1).
3. Disconnect the compressed-air tube (5) and the extraction hose (3) from the extraction hood (4).
4. Remove the screws (2) of the extraction hood.
5. Pull out the extraction hood towards you.

6. Pull out the lighting ring towards you.



Fig. 125: Lighting ring



Always wear gloves when touching the protection glass. Fingerprints contain aggressive acids that etch the surface leaving traces that cannot be removed.

7. Unscrew the lens clockwise.

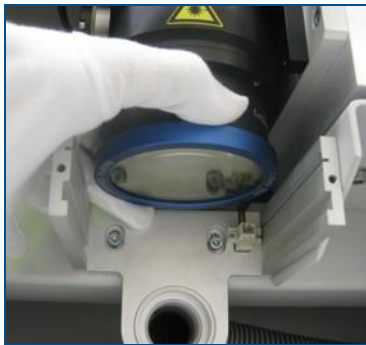


Fig. 126: Unscrewing the lens

8. Cautiously place the lens onto the lens-cleaning tissue.
9. Unscrew the fastening ring clockwise.



Fig. 127: Fastening ring

10. Remove the protection glass.



A seal is fitted between the protection glass and the lens. The seal is seated in the groove of the lens. Ensure that the seal is between the protection glass and the lens when assembling the lens.

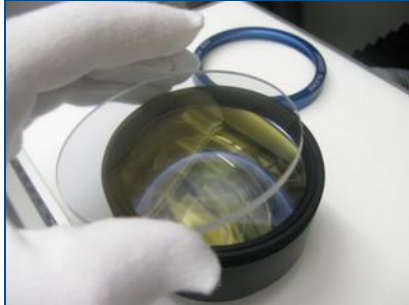


Fig. 128: Removing the protection glass

11. Cover the lens and the protection glass with lens-cleaning tissue.

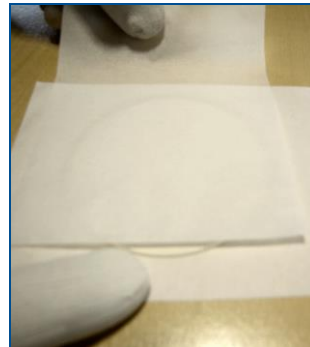
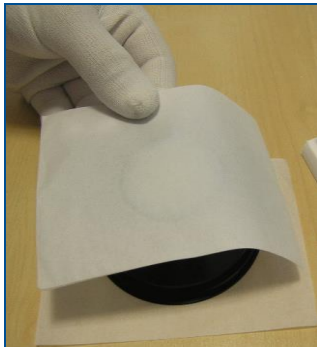


Fig. 129: Covering the lens and the protection glass

WARNING! Health hazard by contact with chemicals!

► **Wear your personal protective equipment according to the safety data sheet.**

12. Sprinkle the protection glass with common isopropyl alcohol.

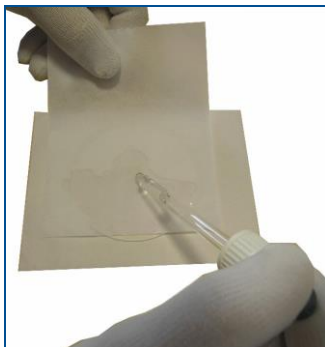


Fig. 130: Sprinkling the protection glass



Quickly pull off the moist lens-cleaning tissue so that no film develops on the protection glass.

13. Hold the protection glass firmly and pull the lens-cleaning tissue across with the other hand.

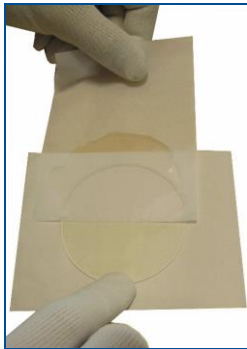


Fig. 131: Cleaning the protection glass

14. Repeat the cleaning procedure with a new lens-cleaning tissue until the protection glass is clean and no streaks or droplets are visible.
 15. Reassemble the mentioned components in reverse order.
 16. Close the maintenance door in the processing area.
- The protection glass of the processing head has been cleaned.

8 Troubleshooting

This chapter contains an overview of possible faults and measures for troubleshooting.

If faults occur that cannot be eliminated by the following messages contact the LPKF Service.

8.1 Fault display

The stack light (see chapter 1.9) of the system indicates occurring faults. The software displays faults in the *Fault monitor* pane.

Fault monitor

The pane *Fault monitor* contains a list of all faults. These can refer for example to error messages during part production or to a problem while starting the system.

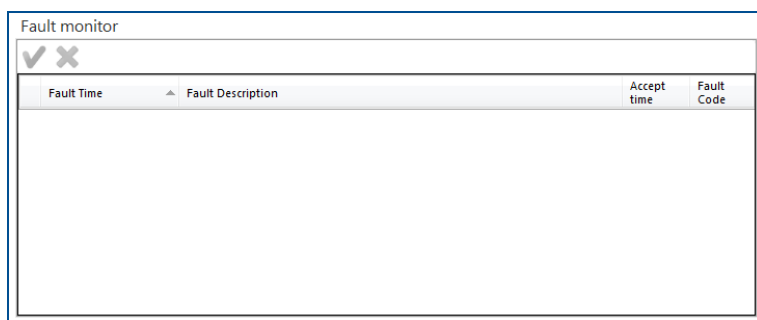


Fig. 132: Fault monitor

Column	Description
Fault Time	Displays the time and date when the error occurred.
Fault description	Detailed description of the error that occurred.
Accept time	Time when the error was acknowledged.
Fault Code	Error code

Table 20: Fault monitor


Icon	Name	Description
	Accept all	All errors not yet acknowledged are acknowledged automatically.
	Clear all	All errors already acknowledged are deleted from the list.

Table 21: Icons in fault monitor

8.2 Actions in case of an error

Errors that have occurred can be cleared in the pane *Fault monitor*.

■ Clearing faults

1. Read the description of the fault in the *Fault monitor* pane.
 2. Click on .
- The system automatically corrects the faults and is initialized. The operation mode indicated by the stack light changes to green (ready for operation). The cleared faults are removed from the *Fault monitor* pane.
 - The fault has been cleared.



If the faults still exist after initialization, restart the system software. If you have any questions contact the LPKF Service.

8.3 Fault table

The following table contains possible faults and proposals how to clear them.

Error message	Error description
Control unit	
0 to 699	Contact the LPKF Service!
700	Exception
701	Connection lost
702	Synchronization lost
703	Deadline (too late)
704	Event lost
705	Buffer overrun
706	Limit switch fault
707	Hardware fault
708	Delete mode
709	Encoder fault
710	I/O event occurred (critical)
711	CanOpen event occurred (critical).
712	Excessive temperature or overcurrent occurred at output stage (self-protection) The controller has been switched off.
713	The control error $\text{abs}(\text{reference} - \text{control_variable})$ is too large (larger than $\text{ac_max_control_error}$). The controller has been switched off.
714	The sensor of the axis controller did not have a valid signal. At the moment only used in <code>SENSOR_MODE_POSITION_IP</code> (internal interpolation of an analog encoder signal). The controller has been switched off.
715	Supply voltage of motors too low The controller has been switched off.

Error message	Error description
716	Lower limit of the movement area reached (softframe error).
717	Upper limit of the movement area reached (softframe error).
718	The controller received a move command but the status of the axis controller was 'OFF' (switched off). The move could not be executed.
719	The modeled motor temperature has exceeded the permitted maximum temperature. The controller has been switched off to prevent damage by excessive temperature.
Laser module	
EMS_STOP	The safety circuit has been triggered by opening the cover.
E04 Comm with LAS_CTRL_Err	Contact the LPKF Service!
E05 LAS_CTRL_Err	Contact the LPKF Service!
E06 X2/X601 sett.fault	Contact the LPKF Service!
E13 Chiller water flow low	Check the tubes and hoses of the cooling system for blockage – visual check. Restart the system. Clean the filter of the chiller.
E14 Chiller water temp H/L	Check the climatic conditions. Check the minimum space requirements of the system. Check the filter of the chiller. Wait for 15 minutes and start the system again.
E15 Chiller water.level Low	Check the chiller. Check the fill level indicator of the chiller. Fill coolant into the chiller, if necessary. Restart the system.
E16 Saf.shut op. Err /Cover up	Contact the LPKF Service!
E17 Saf shut cl.Err	Contact the LPKF Service!
E23 LD undervoltage	Contact the LPKF Service!
E24 Curr.reg.SAF circuit. open	Restart the system. Contact the LPKF Service!
E25 Curr reg OTP	Check the minimum space requirements of the system. Clean the filter of the laser module. Wait for 60 minutes and start the system again.
E26 48V.temp.reg. fault	Contact the LPKF Service!
E27 TEMP REG OVC	Check the filter of the chiller. Wait for 60 minutes and start the system again.
E28 TEMP REG OTP	Check the climatic conditions. Check the minimum space requirements of the system. Clean the filter of the laser module. Wait for 60 minutes and start the system again.
E30 LD temp meter fault	Contact the LPKF Service!

Error message	Error description
E31 Fan 1 fault	Restart the system. Contact the LPKF Service!
E32 Fan 2 fault	Restart the system. Contact the LPKF Service!
E34 Cristal 1 Temp Err"	Contact the LPKF Service!
E35 Cristal 2 Temp Err"	Contact the LPKF Service!
E41 RF R.Power Err	Contact the LPKF Service!
E42 RF R.Power Err	Contact the LPKF Service!
E43 RF Overtemp. Err	Check the minimum space requirements of the system. Clean the filter of the laser module.
E53 Chiller water flow low	Check the tubes and hoses of the cooling system for blockage – visual check. Restart the system. Contact the LPKF Service!
E54 Chiller water temp H/L	Check the climatic conditions. Check the minimum space requirements of the system. Check the filter of the chiller. Wait for 15 minutes and start the system again.
E55 Chiller water level Low	Check the fill level indicator of the chiller. Fill coolant into the chiller if necessary. Restart the system.
E57 Saf.shut.Err/cover up	Contact the LPKF Service!
E60 LT temp under 7°C	Check the climatic conditions. Restart the system.
E61 LT temp over 39°C	Check the climatic conditions. Check the chiller. Restart the system.
E63 LD undervoltage	Contact the LPKF Service!
E64 Curr_reg SAF circuit open	Restart the system. Contact the LPKF Service!
E65 Curr reg OTP	Check the minimum space requirements of the system. Clean the filter of the laser module. Wait for 60 minutes and start the system again.
E66 48V temp reg fault	Contact the LPKF Service!
E67 TEMP REG OVC	Check the filter of the chiller. Wait for 60 minutes and start the system again.
E68 TEMP REG OTP	Check the climatic conditions. Check the minimum space requirements of the system. Clean the filter of the laser module. Wait for 60 minutes and start the system again.
E70 LD temp. meter over 35°	Check the climatic conditions. Check the chiller. Restart the system.

Error message	Error description
E71 Fan 1 fault	Restart the system. Contact the LPKF Service!
E72 Fan 2 fault	Restart the system. Contact the LPKF Service!
E73 LD temp. out to High	Check the climatic conditions. Check the chiller. Restart the system.
E74 Crystal 1 Temp Err	Contact the LPKF Service!
E75 Crystal 2 Temp Err	Contact the LPKF Service!
E76 LD temp.out to Low	Check the climatic conditions. Check the chiller. Restart the system.

Table 22: Fault table

8.4 Processing quality

Fault	Possible cause	Remedy
Burn-in effects of the laser beam at the start points	Laser-on delay too short	Increase the laser-on delay
Burn-in effects of the laser beam at the end points	Laser-off delay too long	Reduce the laser-off delay
Remaining gaps when structuring closed paths	Start point: Laser-on delay too long	Reduce the laser-on delay
Structures are not fully lasered	End point: Laser-off delay too short	Increase the laser-off delay
At the structure start, an inlet or overshoot is visible	Jump delay too short	Increase the jump delay
Corners of polygons are rounded	Polygon delay too short	Increase the polygon delay
	Mark speed too high	Reduce the mark speed
Burn-in effects at the end points of polygon vectors	Polygon delay too long	Reduce the polygon delay

Table 23: Processing quality



For detailed information on setting the tool parameters invoke the help function by pressing **[F1]**.

9 Disassembly and disposal

This chapter describes the disassembly and the disposal of the system.

The following tasks may only be performed by the **maintenance personnel of the operator**.

9.1 Safety

NOTICE

Environmental hazard by improper disposal of the system!

Improper disposal of the system can cause hazards to the environment.

- ▶ Dispose of the system properly or contact the LPKF Service.

9.2 Preparations

Before disassembling the system:

- Switch off the system.
- Disconnect all external components and de-energize the residual energy.
- Remove all operating materials, auxiliary materials, and consumables and dispose them of in an ecological way.

9.3 Disposing of the system

In case there is no agreement on return of goods or an agreement on dispose of the system, the operator is obligated to dispose of the delivered goods at its own expense according to the current laws and local regulations.

10 Appendix

This chapter contains navigation elements of the document.

10.1 List of figures

Fig. 1:	Functional principle of a laser.....	14
Fig. 2:	System with safety devices	26
Fig. 3:	Securing against restart	28
Fig. 4:	Type label	34
Fig. 5:	System overview with open cover	35
Fig. 6:	Beam conditioner.....	36
Fig. 7:	Scan field creation	37
Fig. 8:	Cushion and barrel distortion	37
Fig. 9:	Cushion-barrel distortion	38
Fig. 10:	Calibrated scan field	38
Fig. 11:	x/y table	39
Fig. 12:	Extraction hood.....	39
Fig. 13:	Overview extraction system	41
Fig. 14:	Compressor	42
Fig. 15:	Connectors	43
Fig. 16:	Connections for compressed-air nozzles and extraction hood	44
Fig. 17:	Control lever in horizontal position	44
Fig. 18:	Control lever in vertical position	44
Fig. 19:	USB port (power meter connector).....	45
Fig. 20:	Displays and control elements at the system front.....	46
Fig. 21:	Displays and control elements behind maintenance door	48
Fig. 22:	Displays and control elements in processing area	49
Fig. 23:	Displays and control elements at the rear of the system	50
Fig. 24:	Desktop icon CircuitPro PL	52
Fig. 25:	User interface CircuitPro PL.....	52
Fig. 26:	Key switch <i>SERVICE KEY</i>	53
Fig. 27:	Lifting off the lid	55
Fig. 28:	Packaging without front	56
Fig. 29:	Packaging without panels.....	57
Fig. 30:	Transport ramps	57
Fig. 31:	Placing the transport ramps	58
Fig. 32:	Fastening the transport ramps	58
Fig. 33:	Leveling foot	58
Fig. 34:	Transport supports	59
Fig. 35:	Leveling foot	61
Fig. 36:	System with open cover	62
Fig. 37:	Precision frame spirit level	63
Fig. 38:	Minimum required space	65
Fig. 39:	Workplace of the operating personnel.....	66
Fig. 40:	Center of gravity of the system.....	67
Fig. 41:	Opening the maintenance door.....	69
Fig. 42:	Transport lock for chiller	70
Fig. 43:	Chiller	71
Fig. 44:	x axis	72
Fig. 45:	Pulling out the bolt.....	72
Fig. 46:	Opening the maintenance door.....	73
Fig. 47:	Chiller	74
Fig. 48:	Rear cover	75
Fig. 49:	Grounding cable	75
Fig. 50:	Line filter of the chiller	76
Fig. 51:	Connecting the cable.....	77

Fig. 52:	Stack light markings	78
Fig. 53:	Turning the stack light	78
Fig. 54:	Extraction system with prefilter unit	79
Fig. 55:	Connector for extraction system	79
Fig. 56:	Connector for the control cable	80
Fig. 57:	Connector for the control cable	80
Fig. 58:	Air outlet nozzle	80
Fig. 59:	Wall socket	80
Fig. 60:	Connector for compressed-air tube	81
Fig. 61:	Connecting the network cable	82
Fig. 62:	Network connector	82
Fig. 63:	DisplayPort connector	83
Fig. 64:	DisplayPort at bottom of screen	84
Fig. 65:	USB port	84
Fig. 66:	USB port at bottom of screen	84
Fig. 67:	USB port at bottom of screen	84
Fig. 68:	Connector for mains cable at bottom of screen	85
Fig. 69:	Mains cable	85
Fig. 70:	Connector for mains cable	86
Fig. 71:	Wall socket	86
Fig. 72:	Main switch set to <i>I ON</i>	87
Fig. 73:	Desktop icon CircuitPro PL	90
Fig. 74:	Dialog <i>New document</i>	90
Fig. 75:	Dialog <i>Material settings</i>	91
Fig. 76:	User interface CircuitPro PL	91
Fig. 77:	Message <i>System connection</i>	91
Fig. 78:	Dialog <i>Checking signal lights</i>	91
Fig. 79:	Dialog <i>Import</i>	92
Fig. 80:	Assign layer	93
Fig. 81:	Imported data in the <i>CAM</i> view	93
Fig. 82:	Inserting fiducials	94
Fig. 83:	Context menu	94
Fig. 84:	Message <i>Computation results</i>	94
Fig. 85:	Context menu	95
Fig. 86:	Dialog <i>Drill data & fiducials</i>	95
Fig. 87:	Dialog <i>Laser insulate</i>	96
Fig. 88:	Dialog <i>Laser insulate</i>	96
Fig. 89:	Dialog <i>Laser contour routing</i>	97
Fig. 90:	Context menu	97
Fig. 91:	Dialog <i>Compute scan fields</i>	98
Fig. 92:	Scan field Bottom Side	98
Fig. 93:	Context menu	98
Fig. 94:	Dialog <i>Compute scan fields</i>	99
Fig. 95:	Scan field Bottom Side + Top Side	99
Fig. 96:	Message <i>Laser warm up phase in progress</i>	100
Fig. 97:	Message <i>Processing phase: Mount material</i>	100
Fig. 98:	Dialog <i>Material settings</i>	100
Fig. 99:	Dialog <i>Placement</i>	100
Fig. 100:	Message <i>Processing phase: Turn material over</i>	101
Fig. 101:	Message <i>Manual fiducial definition</i>	101
Fig. 102:	Message <i>Board production finished</i>	101
Fig. 103:	Main switch set to <i>0 OFF</i>	102
Fig. 104:	System with open cover	105
Fig. 105:	Lighting ring	106
Fig. 106:	Protection glass	106
Fig. 107:	System with open cover	107
Fig. 108:	Rear cover	108
Fig. 109:	Disconnecting the grounding cable	108

Fig. 110: System without rear cover	109
Fig. 111: Pulling out the coolant filter	109
Fig. 112: Coolant filter	109
Fig. 113: Opening the maintenance door	110
Fig. 114: Air filter	110
Fig. 115: Blowing out the air filter	111
Fig. 116: Opening the maintenance door	112
Fig. 117: Chiller	112
Fig. 118: Air filter	113
Fig. 119: x axis	114
Fig. 120: y axis	115
Fig. 121: Opening the maintenance door	116
Fig. 122: Chiller	117
Fig. 123: Coolant	117
Fig. 124: System with open cover	118
Fig. 125: Lighting ring	119
Fig. 126: Unscrewing the lens	119
Fig. 127: Fastening ring	119
Fig. 128: Removing the protection glass	120
Fig. 129: Covering the lens and the protection glass	120
Fig. 130: Sprinkling the protection glass	120
Fig. 131: Cleaning the protection glass	121
Fig. 132: Fault monitor	122

10.2 List of tables

Table 1: Effects of laser radiation	15
Table 2: Sources of danger	15
Table 3: Laser classes	16
Table 4: Personal protective measures	17
Table 5: Structural protective measures	17
Table 6: Organizational protective measures	18
Table 7: Safety devices	27
Table 8: Service life	27
Table 9: Starter kit ProtoLaser	33
Table 10: Type label	34
Table 11: Pin assignment	45
Table 12: Displays and control elements at the system front	47
Table 13: Displays and control elements behind maintenance door	48
Table 14: Displays and control elements in processing area	49
Table 15: Displays and control elements at the rear of the system	50
Table 16: Recommended system configuration CircuitPro PL	51
Table 17: Minimum system configuration CircuitPro PL	51
Table 18: Maintenance schedule for the maintenance personnel of the operator ...	104
Table 19: Maintenance schedule for the LPKF Service	105
Table 20: Fault monitor	122
Table 21: Icons in fault monitor	122
Table 22: Fault table	126
Table 23: Processing quality	126

10.3 Index

B

beam conditioner 38

C

cataract 16
 cleaning agents 32
 climatic conditions 33, 67
 compressed-air purity 33, 69
 coolant additive 32

D

duration of irradiation 15

E

electrical data 33, 69
 emergency stop button 50
 emissions 34
 extraction hood 42
 extraction system 43
 connecting 80

G

Glystantin 32

H

hazards
 laser radiation 14

K

keratitis 16

L

laser beam 15
 laser class 34
 laser classes 17
 laser data 34
 laser protection officer 14
 laser protective glasses 17, 19, 26
 laser radiation 14
 laser radiation hazards 14
 laser safety instructions 14
 list of figures 128
 list of tables 130
 load capacity 33, 68
 lubricants 32

M

main switch 53
 mark speed 34
 max. structuring area 34
 mechanical data 33
 mixing ratio 75, 116

O

on/off switch 50
 operating hours counter 53
 operating states 29, 49

P

pneumatic data 33, 69
 process data 34
 processing procedures 12
 production mode 54
 protective equipment 17
 protective gloves 26
 protective measures 18

R

respirator mask 26

S

safety devices 28
 safety shoes 26
 safety signs 26
 service mode 55
 stack light 29, 49
 switching off the system 90
 switching on the system 90
 system components 37

T

tissue damage 15
 tissue dies off 15
 transport locks
 removing 70

U

UV radiation 16

W

wavelength 14

X

x/y table 41, 73

10.4 EC Declaration of conformity



EC Declaration of conformity according to machinery directive 2006/42/EC Annex II A

The manufacturer/distributor

LPKF Laser & Electronics d.o.o.
Polica 33
SI-4202 Naklo

hereby declares that the following product

Product designation: LPKF Protolaser U4
Product type: LPKF Laser system

conforms to the requirements of the directive stated above - including the amendments in force at the time of the declaration.

This declaration is only valid for the state of the product at the time of delivery. Any parts added by the user or other later modifications are excluded. The declaration becomes invalid if the product is modified after delivery.

The following national or international standards (or parts/clauses) and specifications were applied:

EN ISO 12100:2010	Safety of machinery - Basic concepts, general principles for design, risk assessment
EN ISO 13849-1:2015	Safety of machinery - Safety-related parts of control systems Part 1: General principles for design.
EN 60204-1:2009	Safety of machinery - Electrical equipment of machines Part 1: General requirements.
EN 60825-1:2014	Safety of laser products - Part 1: Equipment classification and requirements.

Name of the documentation representative: Dr. Drago Kovačič
Address of the documentation representative: see address of manufacturer

The following additional EC directives were applied:

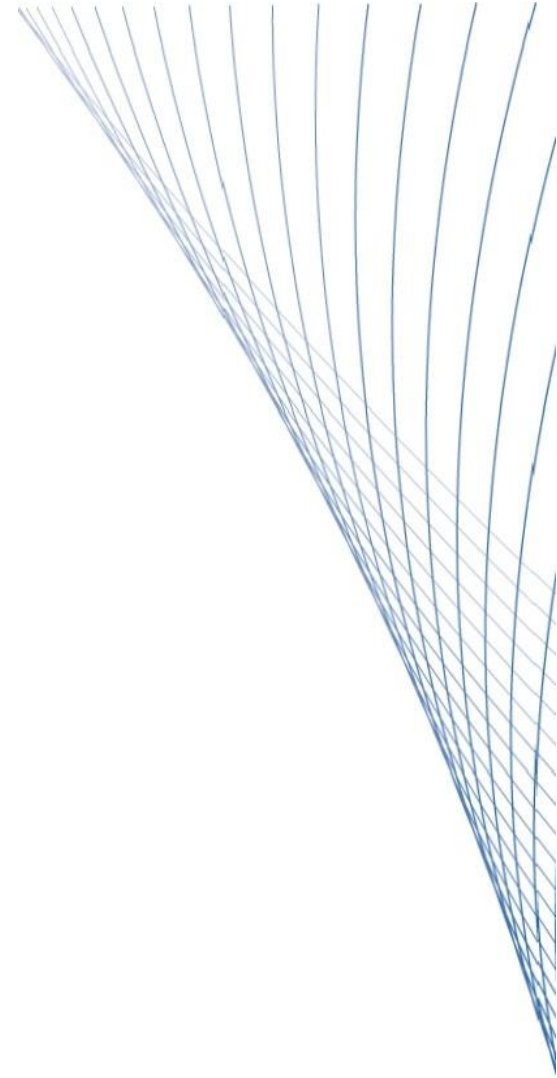
- EMC directive 2014/30/EU
- Low voltage directive 2014/35/EU

Location: Naklo (Slovenia)
Date: 04.12.2015


Dr. Boštjan Podobnik
(Managing Director)


Mr. Wolfgang Zeike
(Managing Director)





LPKF Laser & Electronics AG
Osteriede 7
30827 Garbsen
Deutschland

Telefon +49 5131 7095-0
Telefax +49 5131 7095-90

www.lpkf.com