

LPKF

Laser & Electronics

ProtoMat S

Manual

Version 2.0

English

LPKF Laser & Electronics AG

Osteriede 7

D-30827 Garbsen

Germany

Phone +49-5131-7095-0

Fax +49-5131-7095-90

Email info@lpkf.com

Internet www.lpkf.com

Publisher **LPKF Laser & Electronics AG**
Osteriede 7
D-30827 Garbsen
Germany
Phone: +49-5131-7095-0
Fax: +49-5131-7095-90
Email: info@lpkf.com

Order code 10000447

File name ProtoMat_S_HB_V2.0_ENG.doc

Version 2.0

Creation date 13.12.2011 (dd.mm.yyyy)

Print date 13.12.2011 (dd.mm.yyyy)

Copyright © 2011 LPKF AG
This document and its contents in whole and in part are subject to copyright. The reproduction, translation or duplication of the contents as photocopy or any digital form requires written permission of LPKF AG.

Product and brand names Product and brand names are trademarks of LPKF Laser & Electronics AG, registered among others at the US Patent and Trademark Office: LPKF® and the company logo, # 2,385,062 and # 2,374,780; Solarquipment®, # 3,494,986; ProConduct®, # 3,219,251; Allegro®, # 3,514,950.

General information

Introduction

All information about assembling, start up, operating and maintenance, respectively troubleshooting of the delivered machine are provided by this product manual. This manual is written for persons with a basic knowledge of installing and operating software controlled machines. General knowledge about safety at work as well as basic knowledge about PC handling, based on Microsoft Windows® operating system, is required.

Availability

This document must be available in complete and legible condition at the workplace near the machine. Any person, allowed to operate the machine, must read and understand this manual. The machine owner has the duty to ensure that all safety instructions, described in the manual, will be heeded by the operators.

Notation

To facilitate the reading and understanding of the document information text attributes, text notations and text structures are used. The text attributes (highlighting) inside this document are defined as follows:

Attribute	Function
Bold	Important information
<i>Italic</i>	Brand name
 + <i>Italic</i>	LPKF Brand name
[...]	Button
\...\ <...>	Input or output field Check box
{...}	Radio button
>...>...>	Menu path
/.../	Pointer to a numeric character inside an image

Images

All pictures or graphics of this document are framed. Every figure is characterized with a continuously numbered title, for example “Fig. 1: Overview“. Numeric character inside the image is used for the identification of specified components or operation steps. Sideward showing arrows inside the image are used to indicate an activity direction.

Tables

Any technical data, facts or special context will be organized in tables. Every table is characterized with a continuously numbered title, for example “Tab. 1: Scope of delivery“. The table will be created with a highlighted headline and labelled columns.

General information



Procedure descriptions

For this manual step by step procedures or workflows are compiled to operation sequences. An individual operation sequence consists of at least three components Title+Step+ Result.

Component	Description
■ Title	Short description of the expected result – characterized with a prefixed “■”.
1. Step	A consecutively numbered order of the individual work item of the described procedure.
➔ Partial result	Partial result of an operation step. The operation sequence is continuously progressed.
◆ Result	Result of the operation sequence - characterized with a prefixed “◆”.

Symbols and signal words

Inside this document the following symbols will be used to indicate important information:

Symbol	Description
	Safety instruction WARNING – dangerous hazard to people ATTENTION – a machine damage is possible
	Note The note will be used for any information about the optimal solution for a realisation of a specific function or operation.
	Note The memo will be used for any additional information about a function or operation step.
©	Copyright
®	Registered Trademark

Registered trademark

The LPKF logo and the LPKF product names are registered trademarks of LPKF Laser & Electronics AG.

Microsoft and *Windows* are brand names or registered trademarks of the Microsoft Corporation in USA and/or international.

All other brand names belong to the respective owner.

Standards

The following standards and guidelines had been pursued for the creation of this document:

Standard	Description
DIN 5008 05-2005	Rules for writing and layouting
VDI 4500 Bl.1,2 11-2006	Technical documentation - Definitions and legal basics
IEC 62079 11-2001	Preparation of instructions - Structuring, content and presentation
ISO 12100-2 02-2003	Safety of machinery - Basic concepts, general principles for design - Part 2: Technical principles
DIN EN 60204 01-2006	Safety of machinery - Electrical equipment of machines - Part 1: General requirements

Contents

1	Product description	9
1.1	Product characteristics	9
1.2	Type label	10
1.3	Scope of delivery	11
1.3.1	Accessories	11
1.3.2	Provided components by the operator	12
1.3.2.1	Control computer	12
1.3.2.2	Dust extraction unit	12
1.4	Manufacturer	13
1.5	EC declaration of conformity	14
1.5.1	ProtoMat S43	14
1.5.2	ProtoMat S63	16
1.5.3	ProtoMat S103	18
2	Safety notes	21
2.1	Device safety	21
2.2	General safety notes	23
3	Functional description	25
3.1	Function	25
3.1.1	Permitted machining materials	26
3.2	Machine design	27
3.2.1	Housing	27
3.2.1.1	Side views	29
3.2.2	Working area	30
3.2.2.1	Worktable ProtoMat S43	30
3.2.2.2	Worktable ProtoMat S63	31
3.2.2.3	Vacuum table ProtoMat S103	32
3.2.2.4	Tool magazine	32
3.2.3	Mill/drill head	33
3.2.3.1	Mill/drill head PotoMat S43	33
3.2.3.2	Mill/drill head ProtoMat S63/103	34
3.3	Conditions of use	36
3.3.1	Disclaimer	37
3.4	Technical Data	38
3.4.1	ProtoMat S43	38
3.4.2	ProtoMat S63	39
3.4.3	ProtoMat S103	40
3.5	Emissions	41
3.5.1	Acoustic emission	41
3.5.2	Material emission	41
3.6	Protection of persons	41
3.7	Disposal of waste material	41

4	Transport and storage.....	43
4.1	Transport.....	43
4.1.1	Transport lock.....	43
4.2	Storage.....	43
5	Installation.....	45
5.1	Assembling conditions.....	45
5.2	Unpacking the device.....	46
5.3	Installation and commissioning.....	46
5.3.1	Installation.....	47
5.3.1.1	Remove the transport lock.....	47
5.3.1.2	Connecting the circuit board plotter.....	48
5.3.2	Commissioning.....	50
5.3.3	Remove the dummy tool.....	51
6	Operation.....	53
6.1	Production process.....	53
6.2	Start system.....	54
6.2.1	Tool status monitoring.....	55
6.2.2	Graphical user interface.....	56
6.2.2.1	Menu bar.....	57
6.2.2.2	Function bar.....	58
6.2.3	Window Processing.....	59
6.2.3.1	Manual control of the mill/drill head.....	60
6.2.3.2	Select head.....	61
6.2.3.3	Operate.....	62
6.2.3.4	Move to Position.....	63
6.2.3.5	Head actions.....	64
6.3	Establish a connection.....	65
6.4	Place material.....	67
6.4.1	Worktable.....	67
6.4.2	Vacuum table.....	68
6.5	Tool setup.....	69
6.5.1	Manual tool change procedure.....	69
6.5.2	Automatically tool change process.....	70
6.5.3	Tool colour code.....	72
6.6	Manual drilling.....	73
6.7	Manual milling.....	76
6.8	Automatic mode.....	81
6.8.1	Specify production type.....	82
6.8.2	Loading the CBF file.....	84
6.8.2.1	Production of the printed circuit board.....	85
6.9	Dispense.....	87
6.9.1	Mount dispense set.....	88
6.9.2	Dispense process.....	90
6.10	Shutdown the System.....	93

6.10.1	Saving the CBF file	93
6.10.2	Exit CircuitPro	94
6.10.3	Switch off the circuit board plotter	94
6.10.3.1	Shutdown and switch off the PC	94
6.10.4	Switch off the dust extraction.....	94
7	Trouble shooting	95
8	Maintenance/servicing	97
8.1	Regular maintenance.....	97
8.2	Maintenance	98
9	Storage	99
9.1	Shutdown	99
9.2	Storage	100
9.2.1	Disposal	100
10	Appendix	101
10.1	Tools and consumables.....	101
10.1.1	Tools	101
10.1.1.1	Tool set 1/8"	102
10.1.1.2	HF and micro wave tool set 1/8".....	103
10.1.2	Consumables.....	103
10.1.2.1	Base material.....	103
10.1.2.2	Multilayer material	104
10.1.2.3	Dispense material.....	104
10.2	Glossary.....	105
10.3	List of figures.....	106
10.4	List of tables.....	108
10.5	Index	109

1 Product description

This chapter provides information about the mill/drill plotter system **ProtoMat S**. The **ProtoMat S** system is deliverable in three different machine versions.

1.1 Product characteristics

Using a moving speed of **150 mm/s** and a motor speed of **40,000 to 100,000 min⁻¹** the **ProtoMat S** produces high-end and complex printed circuit board very fast and professionally. With a resolution of **0.25 µm** this machine provides highest precision.

The extensive equipment and the high grade of automation as e.g. automatical exchange of tools, head illumination and a camera for detection of fiducials make the **ProtoMat S** extremely comfortable in its operation. The modern and ergonomically shaped soundproof housing facilitates easy handling. The safe and comfortable employment of the circuit board plotter is thus possible in any working environment without any additional effort.

As an optional accessory you can easily install a camera, a vacuum table and a status light. Optional the **ProtoMat S43** system can be equipped with a camera system.

The **ProtoMat S** is controlled using the easy to operate software **CircuitPro**. Moreover the software is able to import several CAD formats and to generate production data from these files.

Fig. 1: ProtoMat S Series



/1/ ProtoMat S43

/2/ ProtoMat S63

/3/ ProtoMat S103



Start-Up

First of all insert the "Start-Up" CD into the CD drive of your PC and start the utility movie for the delivered **ProtoMat S** system. Follow the instructions to become familiar with the machine and produce your first printed circuit board.

1.2 Type label

The type label is placed on the right side of the X traverse:

Fig. 2: Position type label



/1/ Type label

If any questions occur concerning the identification of your machine and the corresponding equipment always inform the LPKF service about serial number of your machine according to the type label item.

Fig. 3: Typen label information

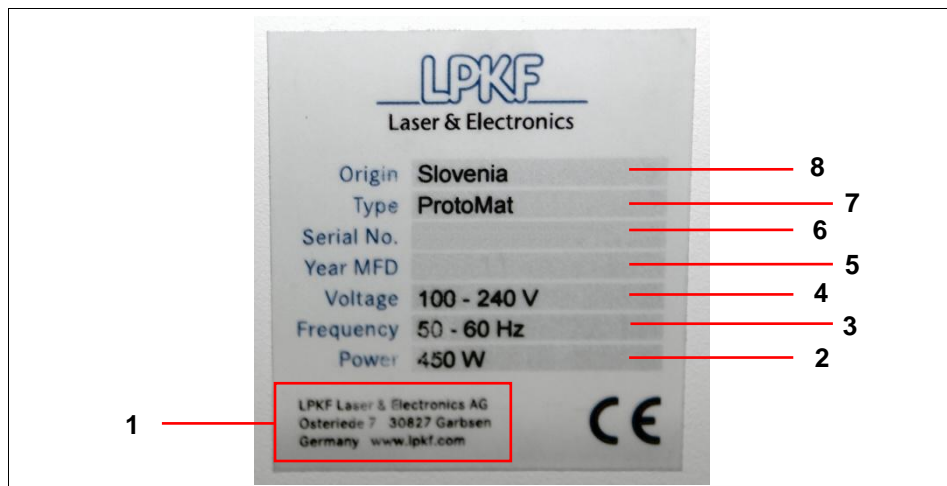

/1/ Manufacturer specifications

/2/ Power consumption, unit W

/3/ Mains frequency range, unit Hz

/4/ Voltage range AC, unit V

/5/ Year of manufacture

/6/ Serial number

/7/ Machine type

/8/ Country of origin

1.3 Scope of delivery

The scope of delivery for the **ProtoMat S Series** includes:

Tab. 1: Scope of delivery

Quantity	Description
1	ProtoMat S series with sound proof housing
1	Power cable with safety plug (230 V AC), length 1,5 m
1	Power cable with US plug (115 V AC), length 1,5 m
1	USB connection cable, 3 m
1	Drill underlay material with the dimensions 229 x 305 mm (9 x 12")
1	Base material FR4 with the dimensions 229 x 305 mm (9 x 12")
1	Tool set with:
2	Reference hole stripes
5	Reference hole pivots (3 x 8 mm)
1	Force fitting tool for reference hole pivots
1	Fuse 10 A (T10L 250 V)
2	Reference hole drill, spiral drill 2.95 mm
1	Fixing tape (to be dissolved residual-free)
1	Maintenance and service set
1	Set of CD-ROMs consisting of
1	Software CircuitPro
1	Start up ProtoMat
1	Set of operation manuals consisting of
1	Operating manual CircuitPro
1	Operating manual ProtoMat S

1.3.1 Accessories

The following components can be delivered as accessories:

Tab. 2: Accessories

Quantity	Description
1	Tool set 1/8"
1	HF tool set 1/8"
1	Dust extraction unit with auto switch feature
1	Vacuum table to fix work pieces
1	Vision System for detection of fiducials (option for ProtoMat S43)
1	Measuring microscope to check milling tracks and drill holes
1	Status Light

1.3.2 Provided components by the operator

The following components are not included in the delivery and have to be provided by the operator.

1.3.2.1 Control computer

A control computer with the following technical data has to be installed by the operator:

Tab. 3: PC data

Component	Technical data
CPU	IBM compatible from Intel Pentium IV or higher (comparable to Dual Core 2 GHz)
RAM	At least 1 GB DDR2 RAM
Hard disk	2 GB free space on internal hard disc drive
Graphic board	NVIDIA with at least 512 MB graphics memory
Screen resolution	1280 x 1024 / High Colour (16 Bit)
Monitor	17" VGA colour monitor

1.3.2.2 Dust extraction unit

A dust extraction with the following technical data has to be installed by the operator:

Tab. 2: Data of dust extraction

Features	Data
Exhaust power	0 - 280 m ³ /h
Low pressure	20,000 Pa
Connecting adapter	Ø 50 mm
Sound level	62 dB (A)
Collection efficiency	> 98 %
Power consumption	1.1 kW



Note

We recommend using a dust extraction unit type **LPKF Air Management System**.

1.4 Manufacturer

LPKF

LPKF Laser & Electronics AG
Osteriede 7
D-30827 Garbsen
Germany
Phone +49 (0)5131 - 70 95 - 0
Fax +49 (0)5131 - 70 95 - 90
Email info@lpkf.com
Internet <http://www.lpkf.com>

LPKF Service

LPKF Laser & Electronics AG
Service Rapid Prototyping
Osteriede 7
D-30827 Garbsen
Germany
Phone +49 (0)5131 - 70 95 - 0
Fax +49 (0)5131 - 70 95 - 90
Email support.rp@lpkf.com
Internet <http://www.lpkf.de/support/index.htm>

1.5 EC declaration of conformity

1.5.1 ProtoMat S43

EC declaration of conformity in accordance with machinery directive 2006/42/EG, Appendix II A

The manufacturer/seller

LPKF Laser & Electronics AG
Osteriede 7
30827 Garbsen
Germany

hereby declares that the following product

Product name	LPKF ProtoMat S43
Product type:	Mill/drill plotter

conforms to the provisions of the directive identified above – including the modifications effective at the time of this declaration.

This declaration refers to the product status where the product was placed on the market. Parts or modifications installed afterwards by the operator are not taken into consideration. Any subsequent modification shall invalidate the declaration for this product.

The following harmonized standards are applied:

EN 60204-1:2007	Safety of machinery - Electrical equipment of machines - Part 1: General requirements
-----------------	---

The following domestic and international standards (or parts/clauses of this standards) and specifications are applied:

EN ISO 12100-2:2004	Safety of machinery - Basic concepts, general principles for design - Part 2: Technical principles
EN ISO 12100-1:2004	Safety of machinery - Basic concepts, general principles for design - Part 1: Basic terminology, methodology
EN ISO 14121-1:2007	Safety of machinery - Risk assessment - Part 1: Principles (ISO 14121-1:2007)

We maintain a quality assurance system according to DIN EN ISO 9001 that has been certified by DeuZert - Certification number: A 40583 22 00 1.

Person authorized to compile the documentation: Rainer Aschenbeck
Address of the person: see manufacturer address

The following EC guidelines are applied:

- EMC guideline 2004/108/EG
- Directive 2006/95/EC relating to electrical equipment designed for use within certain voltage limits

Location: Garbsen
Date: 13. Dezember 2011



Bernd Lange
(CTO)

1.5.2 ProtoMat S63

EC declaration of conformity in accordance with machinery directive 2006/42/EG, Appendix II A

The manufacturer/seller

LPKF Laser & Electronics AG
Osteriede 7
30827 Garbsen
Germany

hereby declares that the following product

Product name	LPKF ProtoMat S63
Product type:	Mill/drill plotter

conforms to the provisions of the directive identified above – including the modifications effective at the time of this declaration.

This declaration refers to the product status where the product was placed on the market. Parts or modifications installed afterwards by the operator are not taken into consideration. Any subsequent modification shall invalidate the declaration for this product.

The following harmonized standards are applied:

EN 60204-1:2007	Safety of machinery - Electrical equipment of machines - Part 1: General requirements
-----------------	---

The following domestic and international standards (or parts/clauses of this standards) and specifications are applied:

EN ISO 12100-2:2004	Safety of machinery - Basic concepts, general principles for design - Part 2: Technical principles
EN ISO 12100-1:2004	Safety of machinery - Basic concepts, general principles for design - Part 1: Basic terminology, methodology
EN ISO 14121-1:2007	Safety of machinery - Risk assessment - Part 1: Principles (ISO 14121-1:2007)

We maintain a quality assurance system according to DIN EN ISO 9001 that has been certified by DeuZert - Certification number: A 40583 22 00 1.

Person authorized to compile the documentation: Rainer Aschenbeck
Address of the person: see manufacturer address

The following EC guidelines are applied:

- EMC guideline 2004/108/EG
- Directive 2006/95/EC relating to electrical equipment designed for use within certain voltage limits

Location: Garbsen
Date: 13. Dezember 2011



Bernd Lange
(CTO)

1.5.3 ProtoMat S103

EC declaration of conformity in accordance with machinery directive 2006/42/EG, Appendix II A

The manufacturer/seller

LPKF Laser & Electronics AG
Osteriede 7
30827 Garbsen
Germany

hereby declares that the following product

Product name	LPKF ProtoMat S103
Product type:	Mill/drill plotter

conforms to the provisions of the directive identified above – including the modifications effective at the time of this declaration.

This declaration refers to the product status where the product was placed on the market. Parts or modifications installed afterwards by the operator are not taken into consideration. Any subsequent modification shall invalidate the declaration for this product.

The following harmonized standards are applied:

EN 60204-1:2007	Safety of machinery - Electrical equipment of machines - Part 1: General requirements
-----------------	---

The following domestic and international standards (or parts/clauses of this standards) and specifications are applied:

EN ISO 12100-2:2004	Safety of machinery - Basic concepts, general principles for design - Part 2: Technical principles
EN ISO 12100-1:2004	Safety of machinery - Basic concepts, general principles for design - Part 1: Basic terminology, methodology
EN ISO 14121-1:2007	Safety of machinery - Risk assessment - Part 1: Principles (ISO 14121-1:2007)

We maintain a quality assurance system according to DIN EN ISO 9001 that has been certified by DeuZert - Certification number: A 40583 22 00 1.

Person authorized to compile the documentation: Rainer Aschenbeck
Address of the person: see manufacturer address

The following EC guidelines are applied:

- EMC guideline 2004/108/EG
- Directive 2006/95/EC relating to electrical equipment designed for use within certain voltage limits

Location: Garbsen
Date: 13. Dezember 2011



Bernd Lange
(CTO)

2 Safety notes

The following chapter lists the most important safety notes for working with the machine and the corresponding control software.

2.1 Device safety



WARNING

Danger to life due to electrical shock!

Missing or inadequate electrical grounding may cause deadly current strokes and/or fire.

The machine must operate connected with a tested protective earth contact socket and the correct earthing must be checked.



WARNING

Danger to life due to electrical shock!

Missing or inadequate electrical fuse protection may cause deadly current strokes and/or fire.

Never bypass any fuses! Use only the fuses recommended by the manufacturer.



ATTENTION

Health hazard due to fine particle and gases!

During machining of work parts harmful fine particles and gases may develop that can be inhaled!

Make sure that dust extraction is activated during machining of the work piece. Use fine particle filters exclusively.



ATTENTION

Risk of injury due to heavy load!

The machine is heavy and bulky, thus it cannot be carried, be lifted or transported by only one person!

Lift and transport the machine always with two persons.



ATTENTION

Risk of injury by unintended operations!

Any accidental starting of the motor and moving of the mill/drill head during repairs and servicing may cause considerable injuries.

Make sure that only one person operates the machine. Secure the machine during servicing and repair activities appropriate.



ATTENTION

Risk of injury by burning!

During the machining process the used tools and the collet chuck heat up so that direct contact may cause burn-ups.

Use safety gloves and a pair of tweezers during manual exchange of tools during operation.



ATTENTION

Risk of injury due to sharp edges!

The employed tools are sharp-edged and cause cuts and stab wounds whenever used improperly.

Always store the tools in their toolbox and protect the toolbox against unauthorised usage.



ATTENTION

Risk of injury by sudden cover closing!

The opened soundproof cover may close accidentally and jam fingers or the complete hand.

Always lift the soundproof cover up to the latching position and secure the machine against any shocks.



ATTENTION

Risk of injury by instable underground!

An instable surface level can collapse and hurt the operator during machining of a work piece due to vibrations and the machine powers.

The machine must be placed on a solid surface.

2.2 General safety notes



General safety notes

Observe any legal accident prevention and labour protection regulations.

Observe the accident prevention and labour protection regulations given by the employer or the industrial union.

Read the operation manual before start up the machine and any usage of the machine. Contact the LPKF service if any problems occur!

The machine must exclusively be operated, repaired and serviced by qualified and authorised staff.

Please wear adequate work clothes respective protective clothing when working at the machine.

Use the machine only according to intended usage.

Never operate the machine in an environment with danger of fire or explosions.

Only operate the machine in proper condition. Make a visual check before any usage and replace faulty cables and tubes at once.

Only operate the machine with correct operating protective devices.

Only operate the machine with tools and accessories licensed by LPKF.

Perform the required service and repair procedure according to the described periods.

Separate the machine from mains power supply whenever you have to perform repairs or servicing.

Always remove damages or functional disturbances at the machine at once. Put the machine out of service and secure it against further usage whenever the damage cannot be removed.

Remove dust and remains of material using a paint brush or draw off any machining remains. Never use compressed air to clean the machine!

Dispose of machining remains according to legal regulations.

Make sure that your work space is always clean.

Always keep children away from the work space.

3 Functional description

In the following chapter describes the function of the circuit board plotter in detail.

3.1 Function

The circuit board plotter **ProtoMat S** is employed for processing of electrical printed circuit boards. Printed circuit boards can consist of several layers (multilayer) and may have up to six layers. In addition the **ProtoMat S** can be employed for processing of signs or housing components (front plate).

The circuit board plotter can be used for the following machining processes:

- Milling and drilling of single or double sided base material
- Milling and drilling of multilayer materials
- Milling of SMD soldering paste stencils
- Milling of solder resist masks
- Engraving of labels or housing plates
- Milling of 3D objects
- Milling of cut-outs and outlines
- Perforating of planar materials
- Dispensing

3.1.1 Permitted machining materials

For reliable and safe operation of the circuit board plotter **ProtoMat S** we recommend to use original LPKF consumables. These articles are available with good value as multilayer sets or they are sold as single material for the different applications.

Tab. 4: Machining materials

Designation	Contents	Usage
FR4 base material, copper-clad	FR4 base material 1,5 mm, 229 x 305 mm (9 x 12"), with or without protective foil, 3 mm reference hole drillings	Production of single or double sided circuit boards
Multilayer set	Base material, surface laminate, prepreg, seal rings	Production of multilayer circuit boards i.e. further processing with the LPKF multilayer press Multipress S
Drilling underlay	Drilling underlay, format DIN A4, 2 mm	Protection of the working table during drilling or during material penetrating drilling
Sinter plate	Air permeable sinter plate for vacuum table (optional)	Work plate or drilling underlay for the vacuum table (optional)
Cleaning pad	Metal-free cleaning pads	Removal of oxidation remains on copper coatings

3.2 Machine design

ProtoMat S series circuit board plotters are constructed equally in principle to facilitate upgrades as simple as possible.

3.2.1 Housing

Fig. 4: Front view



/1/ Soundproof housing

/2/ Cover knob

/3/ Soundproof cover

Fig. 5: Rear view

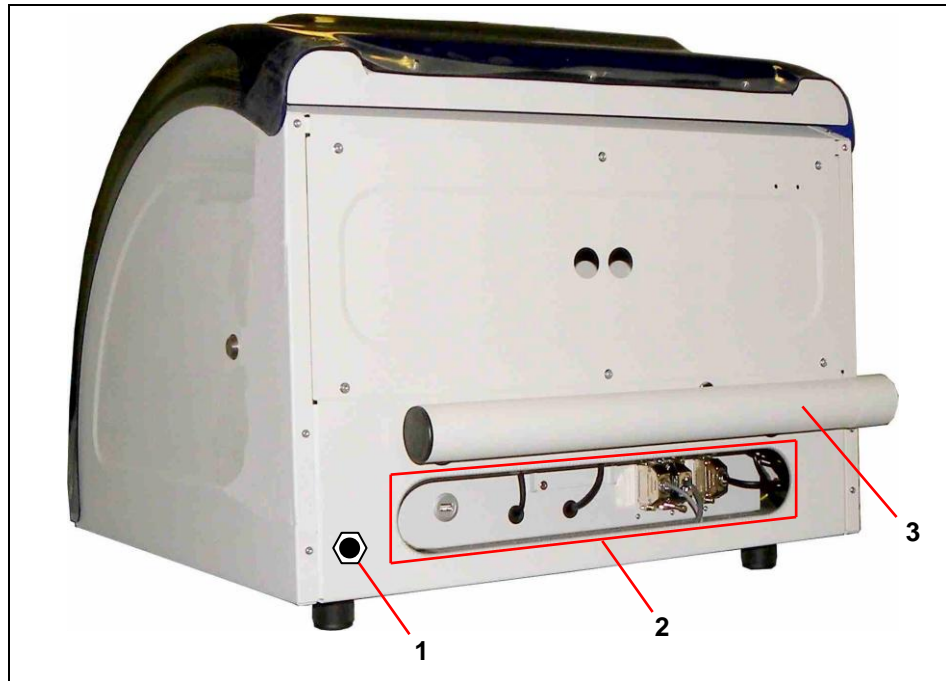

/1/ Compressed air connection for vacuum table

/2/ Interfaces

/3/ Suction tube to connect the dust extraction unit

Fig. 6: Interfaces

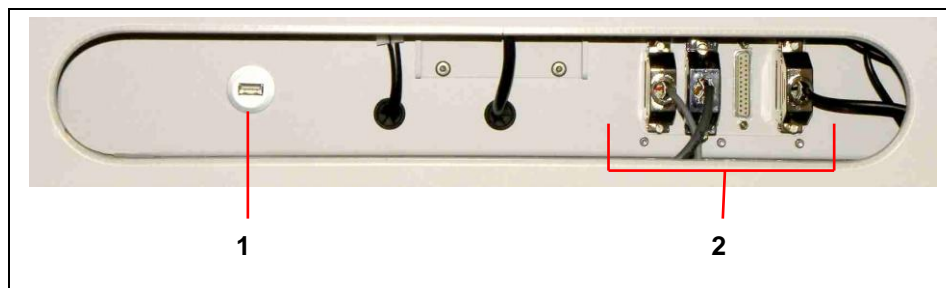

/1/ USB port

/2/ LPKF ports (4 x SUB-D, 25 pin.)

3.2.1.1 Side views

Machine without soundproof housing:

Fig. 7: Right side

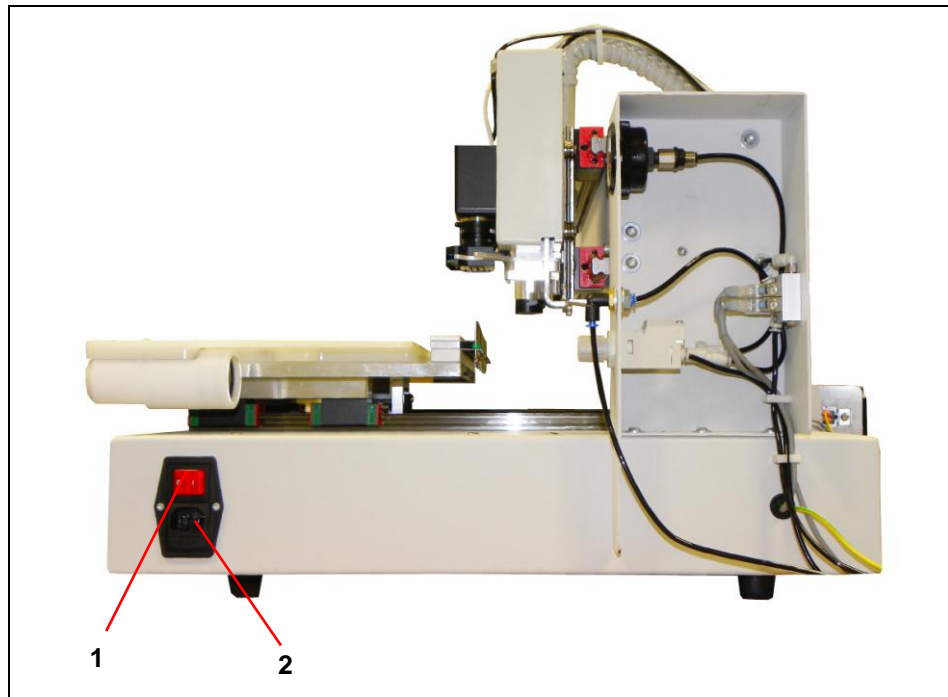

/1/ Power switch

/2/ Mains power connection

Fig. 8: Left side

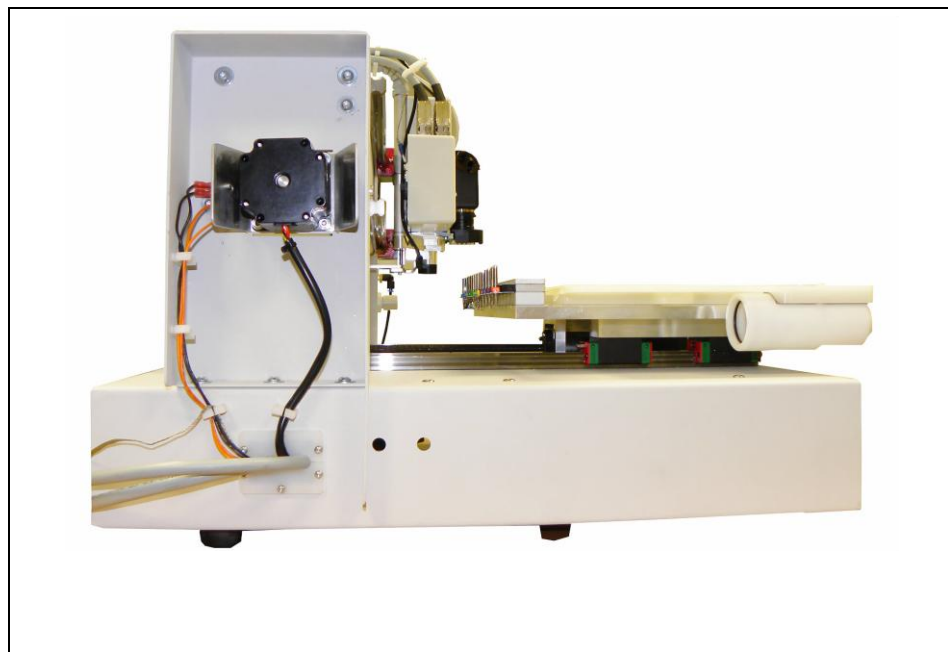

3.2.2 Working area

3.2.2.1 Worktable ProtoMat S43

Fig. 9: Worktable
ProtoMat S43

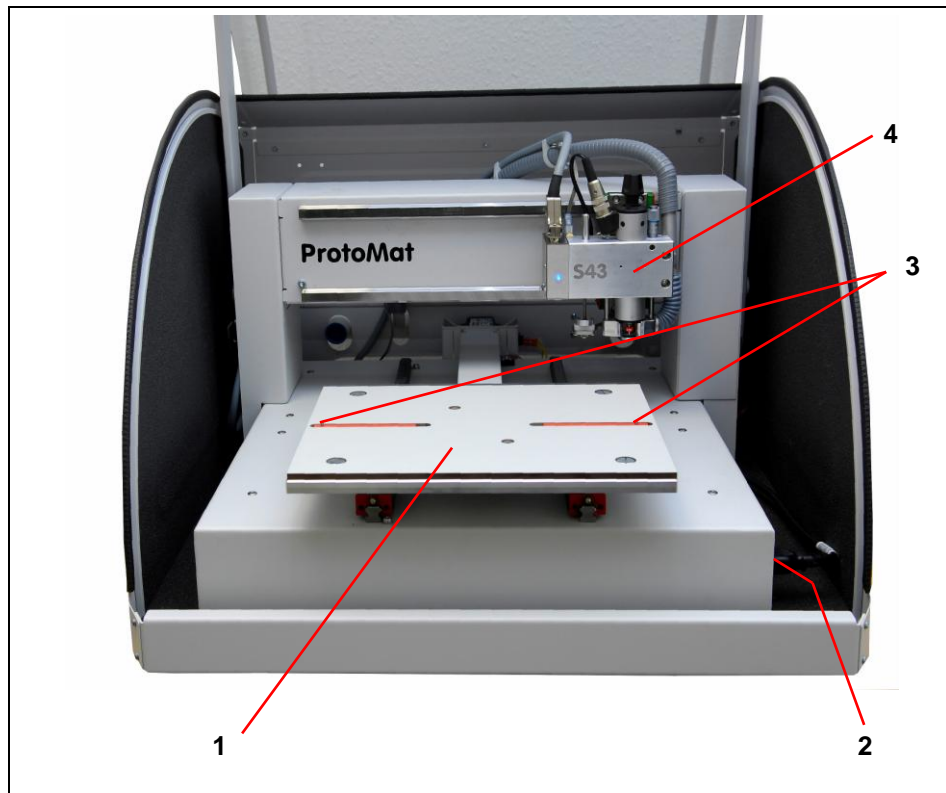

/1/ Worktable

/2/ Power switch

/3/ Fixing pin

/4/ Mill/Drill head

3.2.2.2 Worktable ProtoMat S63

Fig. 10:
Worktable
ProtoMat S43

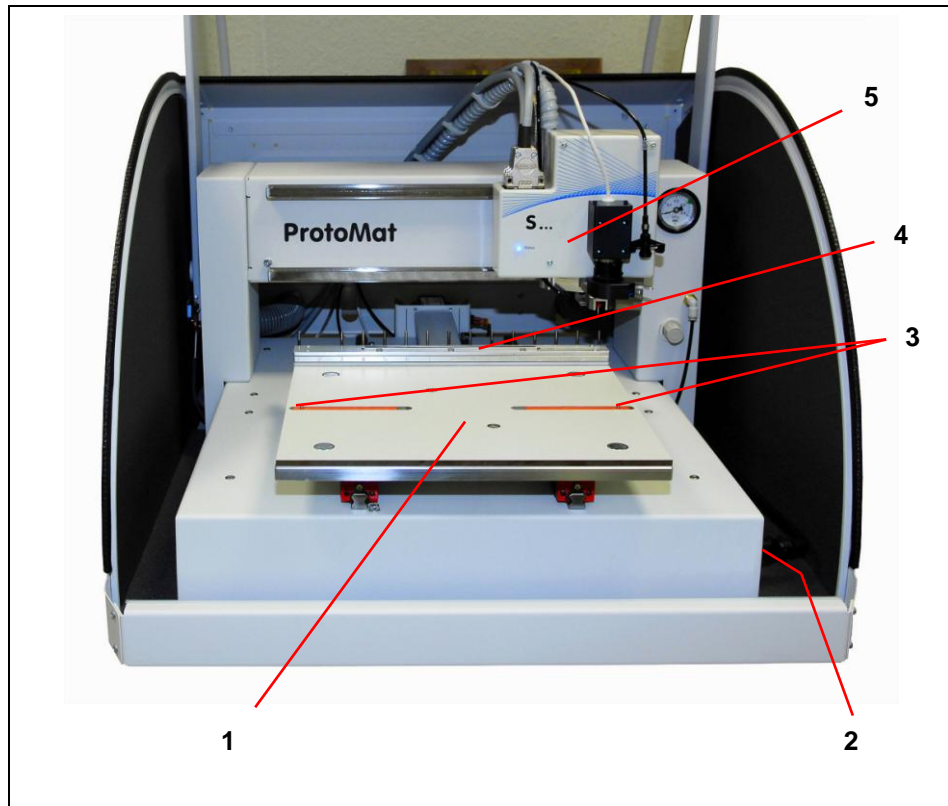

/1/ Worktable

/2/ Power switch

/3/ Fixing pin

/4/ Tool magazine

/5/ Mill/Drill head

3.2.2.3 Vacuum table ProtoMat S103

The vacuum table is optionally available for **ProtoMat S63**.

Fig. 11:
Worktable
ProtoMat S43

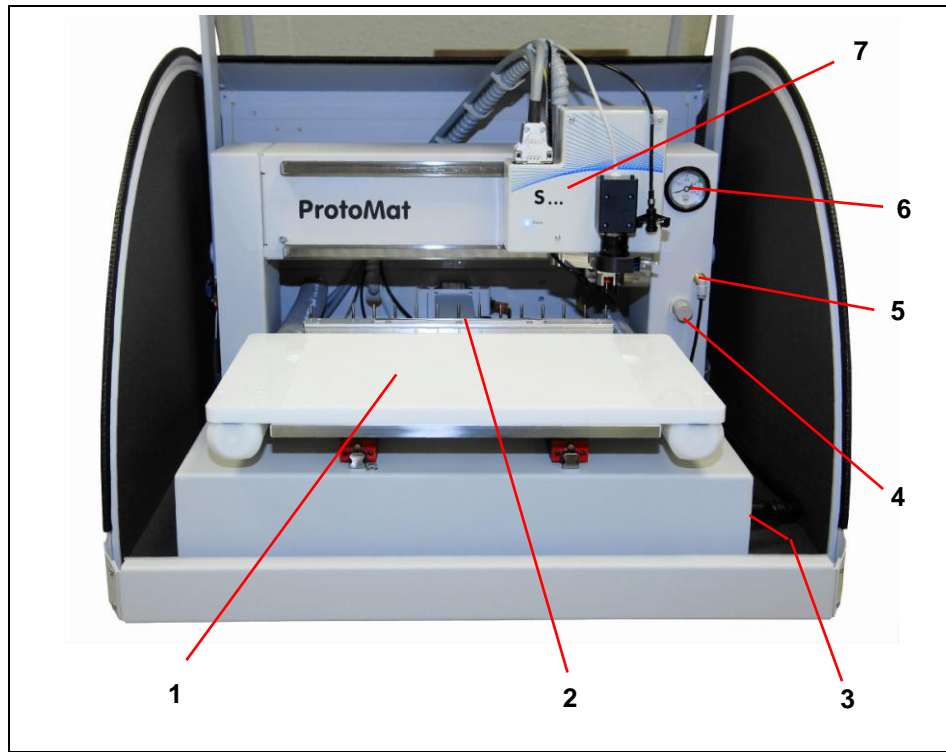

/1/ Vacuum table

/2/ Tool magazine

/3/ Power switch

/4/ Compressed air controller

/5/ Dispenser connection

/6/ Pressure display

3.2.2.4 Tool magazine

The work or vacuum table of machines with automatically tool change function are equipped with a tool magazine.

Fig. 12: Tool
magazine

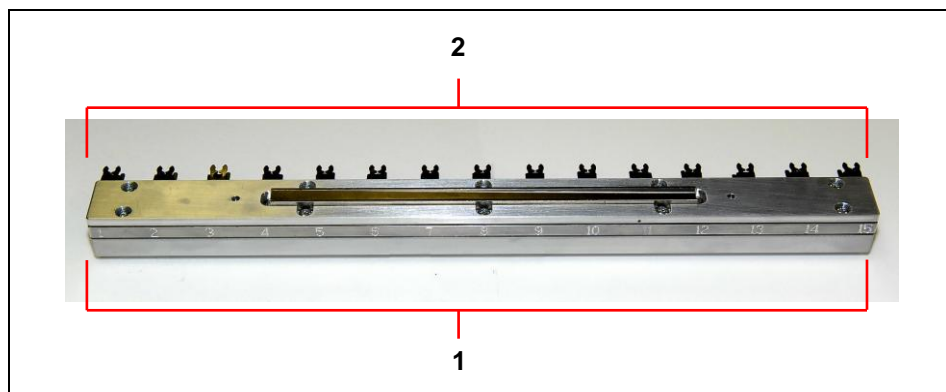

/1/ Tool number 1 ... 15

/4/ Tool clamp 1 ... 15

3.2.3 Mill/drill head

3.2.3.1 Mill/drill head PotoMat S43

Fig. 13: Mill/drill head PotoMat S43

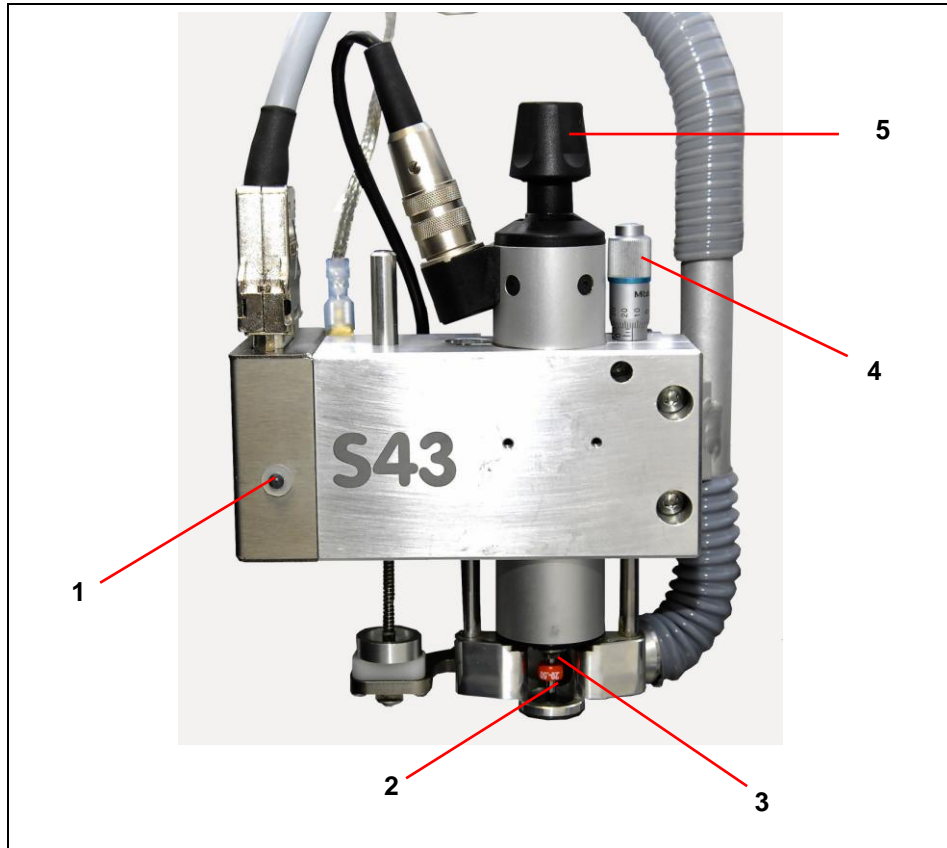

- /1/ Status LED
- /2/ Tool
- /3/ Tool holder
- /4/ Milling depth adjustment (manually)
- /5/ Open/close cullet chuck (manual)

Tab. 5: LED signalling PotoMat S43

LED	Signal
ON	The circuit board plotter is ready for operation.
Flashing	The flashing LED indicates a machine failure.

Fig. 14: Tool holder PotoMat S43

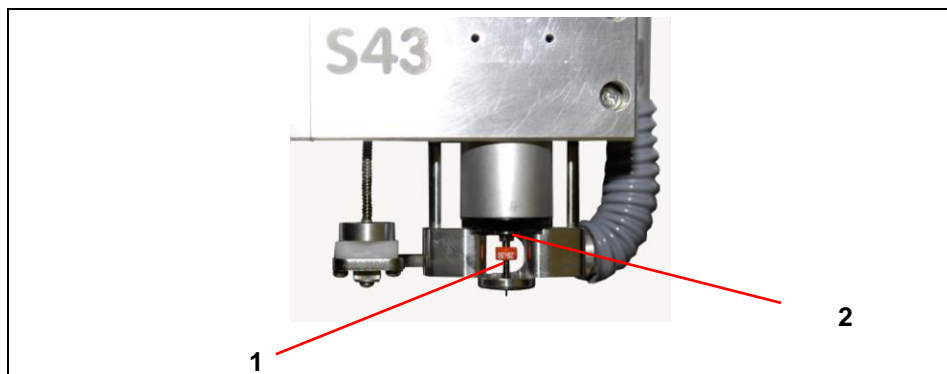

- /1/ Tool
- /2/ Tool holder

3.2.3.2 Mill/drill head ProtoMat S63/S103

Fig. 15: Mill/drill head ProtoMat S63/S103

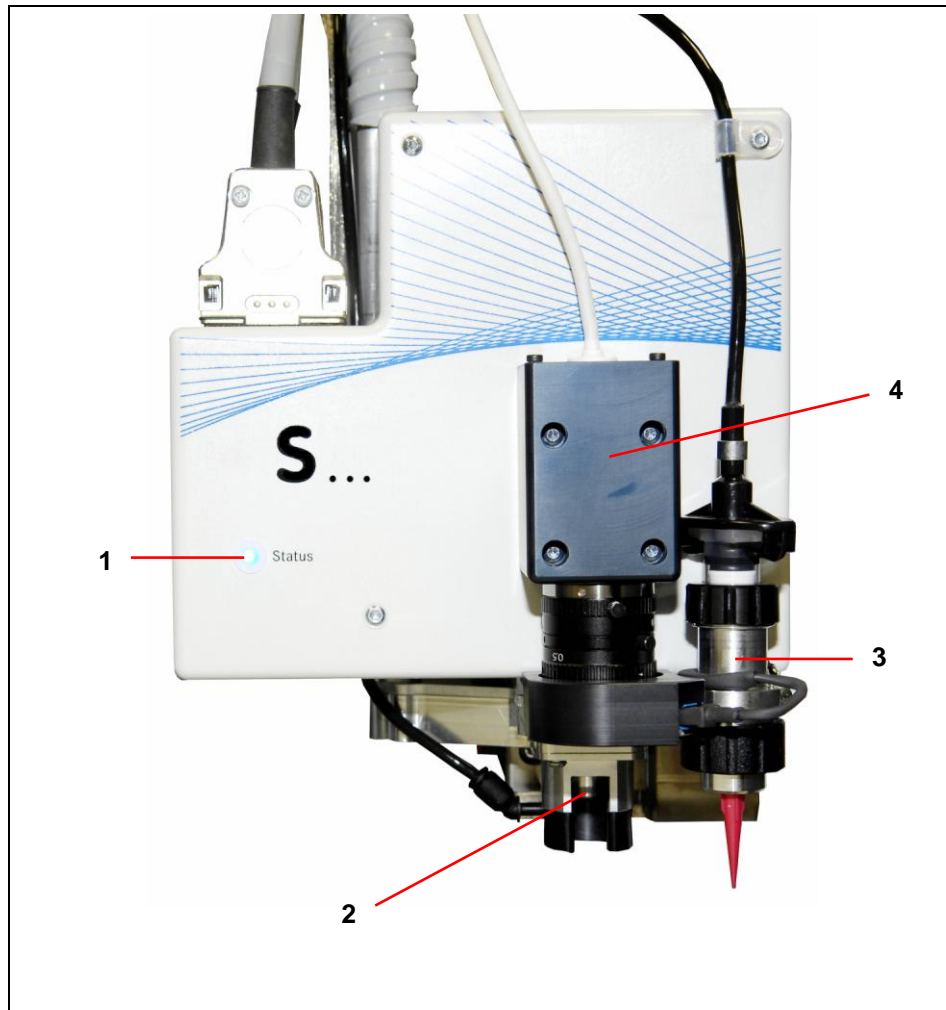

/1/ Status LED

/2/ Tool holder

/3/ Dispenser

/4/ Camera

Tab. 2: LED signalling ProtoMat S63/S103

LED	Signal
ON	The circuit board plotter is ready for operation.
Flashing	The flashing LED indicates the movement of the mill/drill head or a machine failure.

Fig. 16: Tool holder unit

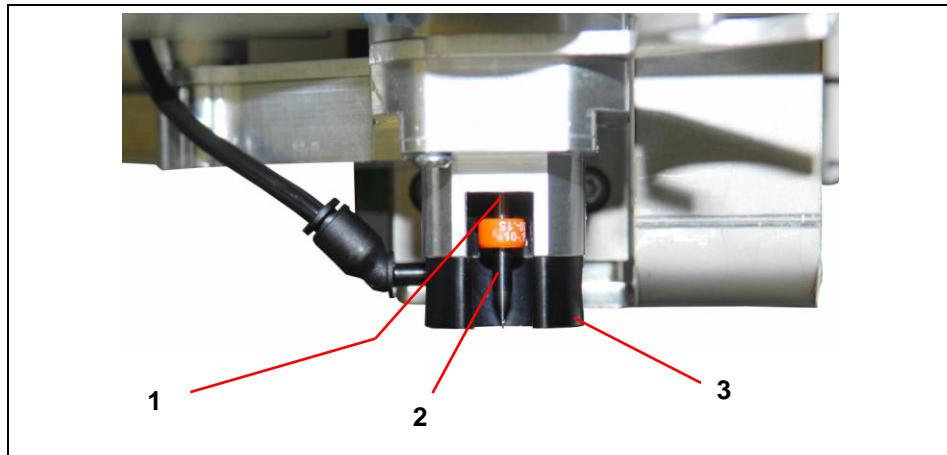

/1/ Tool holder

/2/ Tool

/3/ Work depth limiter

Fig. 17: Camera

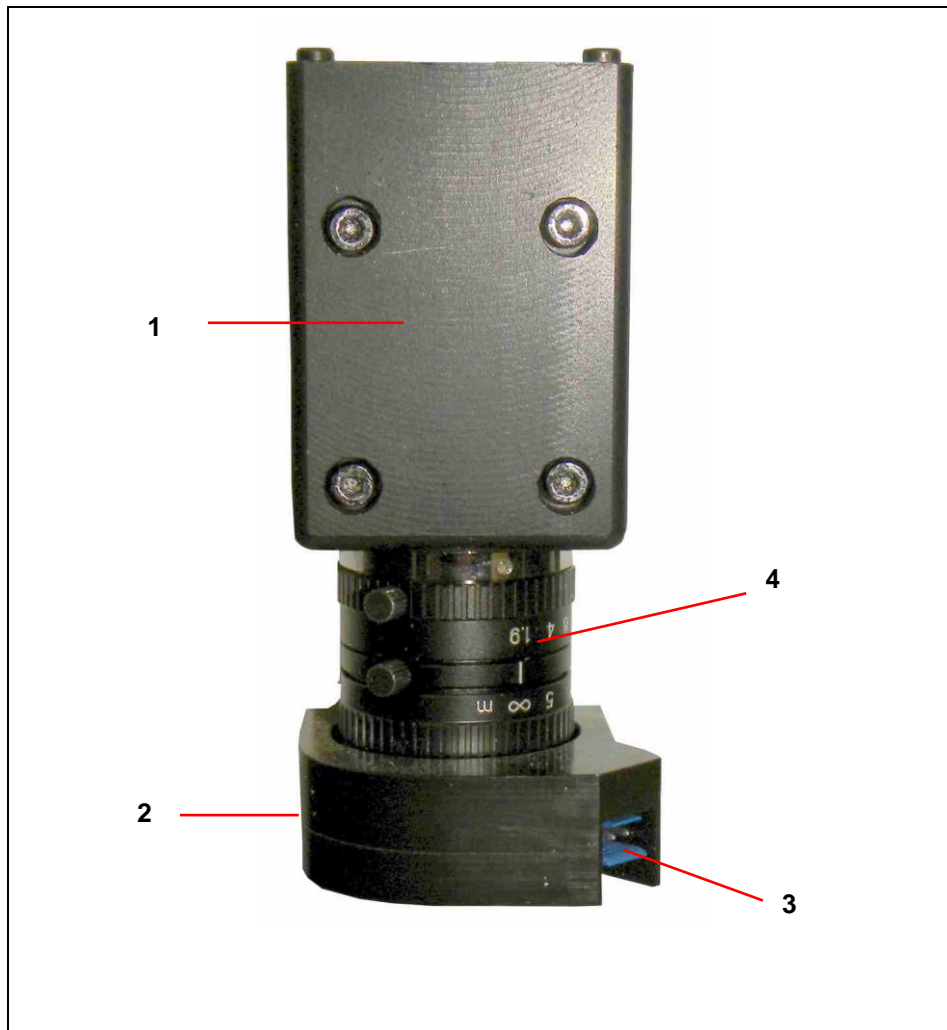

/1/ Camera

/2/ Ring light

/3/ Dispenser interface

/4/ Objective

3.3 Conditions of use

The circuit board plotter can be used for production of single and multi-sided circuit boards. Processing of signs as well as housing parts e.g. back or front plates are acceptable likewise.

Permitted machining processes are:

- Milling and drilling of single and double sided base material
- Milling and drilling of multilayer material
- Milling of SMD soldering paste stencils
- Milling of solder resist mask
- Engraving of signs or housing plates
- Perforation of flat materials
- Milling of cut-outs and outlines
- Milling of 3D objects
- Dispensing

The following materials are permitted for this circuit board plotter:

- GFK or CFK base material
- PTFE or ceramic-filled base material
- Wood
- Nonferrous materials as:
 - Aluminium acc. to DIN EN 573:EN AW-6012
 - Brass acc. to DIN EN 1412: CW603N
- Plastics as:
 - Polyoxymethylen
 - ABS-Copolymere

The circuit board plotter may only be operated for the machining processes and materials listed in this chapter.

The circuit board plotter may only be operated using the delivered control software **CircuitPro**.



Please contact the LPKF service at once if you wish to use an other control software as the delivered item!

Note

The circuit board plotter may only be start up with a sufficient dust extraction and a fine particle filtering.



We recommend the LPKF dust extraction system with integrated HEPA filter.

Memo



Please contact the LPKF service first if you plan to use an other dust extraction system.

Note

The circuit board plotter may not be used for processing of highly combustible materials, closed containers, hollow articles, textiles and foods. Any processing of bodily parts (e.g. fingernails) is not allowed.



Always contact the LPKF service first if you are not sure if the used materials can be processed with the circuit board plotter.

Note

3.3.1 Disclaimer

The circuit board plotter was developed and produced according to state of the art technology and approved safety-related regulations. However improper use or application may cause hazards for body and life of the operator or third persons or impairments of the device or other material assets.

The manufacturer is not liable for damages that occur by improper use or the following type of handlings:

- Improper handling, inclusive any applications not mentioned in this manual
- Applications in improper environments
- Installation and operation with insufficiently trained and informed staff or unauthorised persons
- Nonobservance of legal safety and work protection regulations
- Nonobservance of technical information
- Incorrect installation
- Insufficient mains power supply
- Unimplemented or insufficient maintenance
- Unauthorised technical modifications
- Employment of components or materials or spare parts that are not specially licensed for this circuit board plotter

3.4 Technical Data

3.4.1 ProtoMat S43

Technical data circuit board plotter type **ProtoMat S43**:

Tab. 6: Technical data ProtoMat S43

Data	Values
Mains power supply	Voltage range from 110 to 240 V AC, 50 - 60 Hz
Power consumption	400/450 W
Weight	Appr. 58 kg
Dimension	670 x 540 x 760 mm (W x H x D)
Permissible ambient temperature	Range from 15 to 25 °C
Permissible atmospheric humidity	Up to 60 %
Workplace noise level	71 dB (A), devoid of noise level dust extraction
Motor mill/drill head	Three phase motor
Range of speeds	Up to 40,000 min ⁻¹ (variable)
Processing speed	150 mm/s
Drilling capacity	150 strokes per minute
Tool change mechanism	Manually
Tool collet base	3.175 mm (1/8")
Motor X-axis	Three phases stepping motor
Motor Y-axis	Three phases stepping motor
Motor Z-axis	Two phases stepping motor
Milling depth adjustment	Manually
Working area with work table	305 x 229 x 32.5 mm (X x Y x Z)
Working area with MKHP plate	305 x 229 x 26.5 mm (X x Y x Z)
Working area with vacuum table	305 x 229 x 17 mm (X x Y x Z)
Resolution (X/Y)	+/- 0.8 µm (0.04 Mil)
Repeat accuracy	+/- 5 µm (0.2 Mil)
Exactness reference hole system	+/- 20 µm (0.8 Mil)
Minimal drill diameter	0.2 mm

3.4.2 ProtoMat S63

Technical data circuit board plotter type **ProtoMat S63**:

Tab. 7: Technical data ProtoMat S63

Data	Values
Mains power supply	Voltage range from 110 to 240 V AC, 50 - 60 Hz
Power consumption	400/450 W
Weight	Appr. 58 kg
Dimension	670 x 540 x 760 mm (W x H x D)
Permissible ambient temperature	Range from 15 to 25 °C
Permissible atmospheric humidity	Up to 60 %
Workplace noise level	71 dB (A), devoid of noise level dust extraction
Motor mill/drill head	Three phase motor
Range of speeds	Up to 60,000 min ⁻¹ (variable)
Processing speed	150 mm/s
Drilling capacity	150 strokes per minute
Tool change mechanism	Automatically
Number of tools	Up to 15 tool holder positions, software limit
Tool collet base	3.175 mm (1/8")
Motor X-axis	Three phases stepping motor
Motor Y-axis	Three phases stepping motor
Motor Z-axis	Two phases stepping motor
Milling depth adjustment	Automatically
Working area with work table	305 x 229 x 38 mm (X x Y x Z)
Working area with MKHP plate	305 x 229 x 32 mm (X x Y x Z)
Working area with vacuum table	305 x 229 x 23 mm (X x Y x Z)
Resolution (X/Y)	+/- 0.5 µm (0.02 Mil)
Repeat accuracy	+/- 5 µm (0.2 Mil)
Exactness reference hole system	+/- 20 µm (0.8 Mil)
Minimal drill diameter	0.2 mm

3.4.3 ProtoMat S103

 Technical data circuit board plotter type **ProtoMat S103**:

Tab. 8: Technical data ProtoMat S103

Data	Values
Mains power supply	Voltage range from 110 to 240 V AC, 50 - 60 Hz
Power consumption	400/450 W
Weight	Appr. 60 kg
Dimension	670 x 540 x 760 mm (W x H x D)
Permissible ambient temperature	Range from 15 to 25 °C
Permissible atmospheric humidity	Up to 60 %
Workplace noise level	71 dB (A), devoid of noise level dust extraction
Motor mill/drill head	Three phase motor
Range of speeds	Up to 100,000 min ⁻¹ (variable)
Processing speed	150 mm/s
Drilling capacity	150 strokes per minute
Tool change mechanism	Automatically
Number of tools	Up to 15 tool holder positions, software limit
Tool collet base	3.175 mm (1/8")
Motor X axis	Three phases stepping motor
Motor Y axis	Three phases stepping motor
Motor Z axis	Two phases stepping motor
Milling depth adjustment	Automatically
Working area with work table	305 x 229 x 38 mm (X x Y x Z)
Working area with MKHP plate	305 x 229 x 32 mm (X x Y x Z)
Working area with vacuum table	305 x 229 x 23 mm (X x Y x Z)
Resolution (X/Y)	+/- 0.25 µm (0.01 Mil)
Repeat accuracy	+/- 5 µm (0.2 Mil)
Exactness reference hole system	+/- 20 µm (0.8 Mil)
Minimal drill diameter	0.2 mm

3.5 Emissions

3.5.1 Acoustic emission

The permanent acoustic noise and vibration values of the circuit board plotter do not exceed the legal compulsory acoustic exposition level of 85 dB (A).

Max. noise level (without soundproof hood and dust extraction)	71 dB (A)
--	-----------

The noise level depends on the processing material. At a permanent heavy noise level the operator has to wear an ear protection (one way ear protection or circumaural headphones).

3.5.2 Material emission

During machining of circuit boards or materials dust or fine particles occur. These fine particles are, depending on the material, more or less hazardous to health and must not be expired to the environment. Thus a dust extraction has to be activated during operation of the circuit board plotter that extracts fine particles in a fine particle filter.

3.6 Protection of persons

Any effective legal and internal work protection measures have to be obeyed. According to the application and the material to be processed the operator has to wear appropriate protective clothing, this includes:

- Safety glasses
- Safety gloves
- Ear protection (one-way ear protection or earmuffs)
- Respirator mask

The safety instructions described in chapter 2 (see page 21) have to be obeyed in any case.

3.7 Disposal of waste material

Local laws, directions and regulations as well as company directions concerning waste of material (fine particles and rest materials) have to be obeyed.

Check disposal with the responsible employee of your company e.g. your environmental protection representative.

4 Transport and storage

The following chapter gives some information concerning transport and storage of the circuit board plotter.

4.1 Transport



ATTENTION

Risk of injury due to heavy load!

The machine is heavy and bulky and cannot be transported or lifted by one person!

Lift and transport the machine always with two persons.

For transports over large distances the circuit board plotter has to be stored in the delivered covering box. The covering box has to be placed and fixed on an euro pallet.

For transports over short distances the circuit board plotter can be take out of the covering box to be carried by two persons to the working desk.

4.1.1 Transport lock

Fix the mill/drill head with a transport protection band and place a foam mat under the mill/drill head.

4.2 Storage



Note

The circuit board plotter has to be stored in its covering box in a cool and dry environment.

During longer down or storage times, transport locks have to be installed and the circuit board plotter has to be stored in its covering box. Store the circuit board plotter in a cool and dry location. Use a protective cover to protect it from dust and humidity.

5 Installation

This chapter describes the installation and start up procedure of the circuit board plotter in detail.

5.1 Assembling conditions



ATTENTION

Risk of injury caused by instable underground!

An instable underground that crashes may harm operators due to vibrations and machine powers that may occur during processing of a work piece.

The machine must be placed on a solid surface.

The circuit board plotter has to be placed on a solid work desk with a minimum load capacity of 60 kg. The work area size should not be smaller than 800 x 900 mm.

Fig. 18: Required space

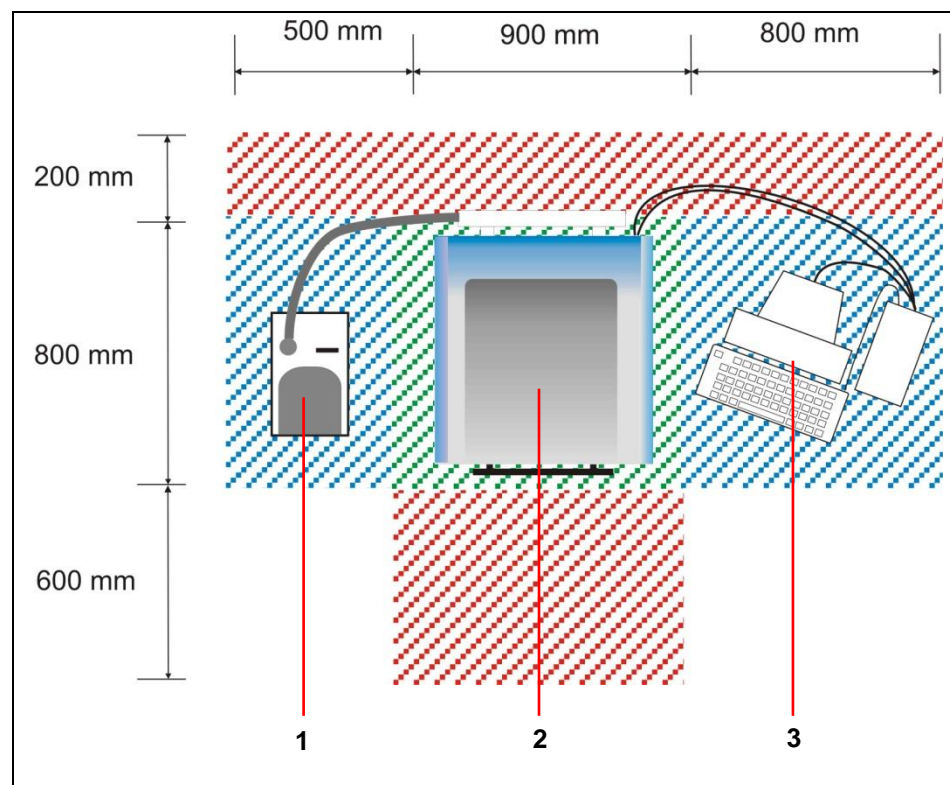

/1/ Dust extraction

/3/ PC

/2/ Circuit board plotter

The areas marked in red are safety zones that must not be blocked with any objects.

5.2 Unpacking the device



ATTENTION

Risk of injury due to heavy load!

The machine is heavy and bulky and cannot be transported or lifted by one person!

Lift and transport the machine with two persons.



NOTE

The graphic unpacking instruction is to be found in the covering box. After having removed the cover of the box you can take the unpacking instruction and proceed as described.

■ Unpacking the circuit board plotter

1. Transport the euro pallet with a lift truck to the work desk.
2. Lift the paper cover from the box.
3. Take the unpacking instruction and follow the instructions step by step.

◆ Now the circuit board plotter is unpacked and ready for installation.

5.3 Installation and commissioning



Note

Prerequisite for installation and start of operation is that the PC and the dust extraction are available at the work place. PC and dust extraction must be ready for operation.



Note

The control software **CircuitPro** has to be installed on the PC.

5.3.1 Installation

The installation of the circuit board plotter must be done in **four** steps:

- I. Remove the transport lock
- II. Connection of the mains cable
- III. Connection of the dust extraction
- IV. Connection of the PC

5.3.1.1 Remove the transport lock

Fig. 19: Transport lock

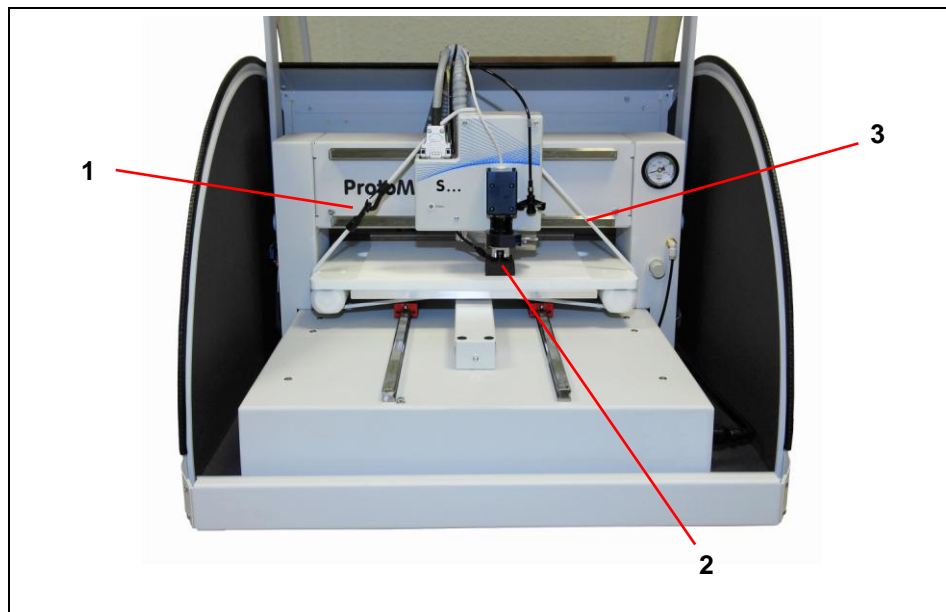

/1/ Carabiner lock

/2/ Foam plastic pad

/3/ Saety strap

■ Remove the transport lock

1. Open the carabiner lock /1/ and remove the safety strap /3/.
2. Remove the foam plastic pad /2/.
3. Put the safety strap and the foam plastic pad into the transport box.

◆ The transport locks are removed.

5.3.1.2 Connecting the circuit board plotter



Note

Switch off the machine when the cable will be connected to the interfaces.

Only one USB cable will be used to the **ProtoMat S43**.



Note

Do not connect a USB hub on the USB interface of the machine. This configuration is not supported.

Fig. 20:
Connections

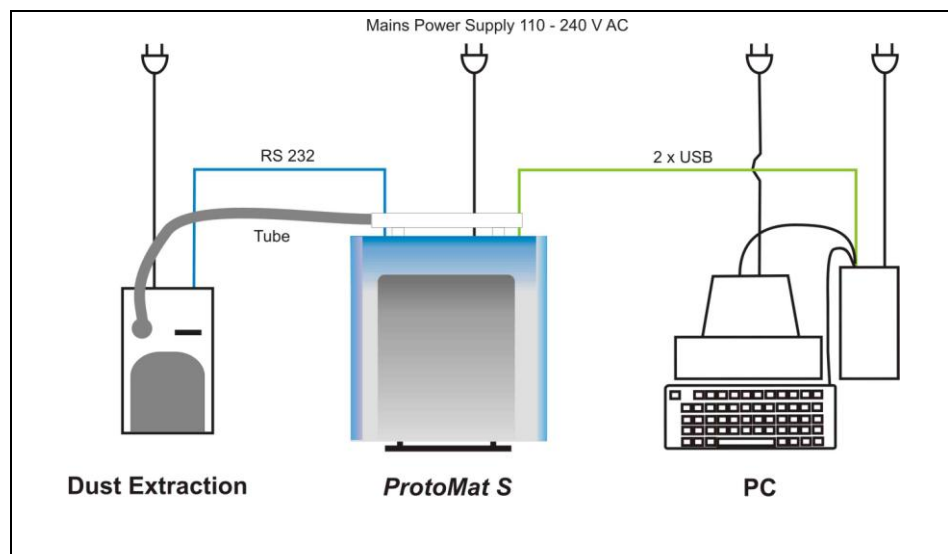

■ Connecting the circuit board plotter

1. Take the delivered **USB cable** and connect the circuit board plotter to the PC (free USB slot).
2. If the camera unit is installed take the pre-installed **USB cable** of the camera and connect it to the PC (free USB slot).
3. Take the **RS232 cable** and connect the circuit board plotter to the dust extraction.
4. Open the soundproof hood of the circuit board plotter.
5. Insert the delivered mains cable into the AC power socket below the main switch.
6. Guide the mains voltage cable alongside the machine through the gap of the machine housing.
7. Connect the circuit board plotter with the mains power supply.
8. Connect the PC with the mains power supply.
9. Connect the monitor with the mains power supply.
10. Connect the dust extraction with the mains power supply.
11. Plug the **tube** of the dust extraction into the suction pipe of circuit board plotter (rear side).

12. Plug the other side of the tube on the coupler of the dust extraction.

For **ProtoMat S103**:

13. Plug the compressed air hose on the compressed air connection of the machine (located on the back side, at the bottom of the left side).
14. Connect the other end of the hose with the central or local compressed air supply.

◆ Now the circuit board plotter is connected.



Note

Do **not** connect any UBB hub to the USB interfaces of the machine. The USB interface does not support this configuration at all.

5.3.2 Commissioning

Always activate the system in the same sequence:

- I. Switch on the PC (control unit)
- II. Switch on the dust extraction and set the operation mode to automatic or constant operation
- III. Switch on the circuit board plotter

■ System start up

1. Start the PC.
2. Switch on the dust extraction.
3. Turn the operation mode switch into the automatic position.
4. Adjust the desired extraction power.
5. Open the cover of the circuit board plotter.
6. Activate the circuit board plotter by setting the main switch to position I **(ON)**.
7. Close the cover.
8. Start **CircuitPro**.

➔ The **CircuitPro** start-up logo is displayed:

Fig. 21: Start-up Logo

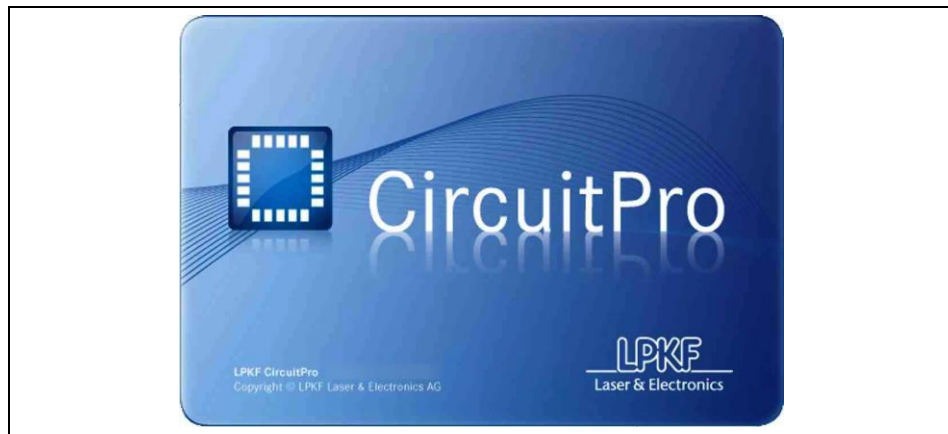

◆ The circuit board plotter is ready.

5.3.3 Remove the dummy tool

Fig. 22: Dummy tool

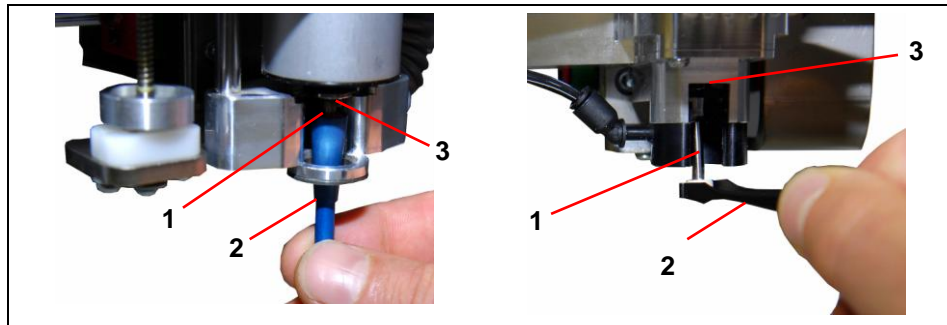

/1/ Dummy tool

/2/ Tool gripper or tweezers

/3/ Collet chuck

■ Remove the dummy tool

1. Take a tool gripper or tweezers and fix the dummy tool.
2. For machines with mechanically tool change mechanism:
 - Turn the adjustment screw of the collet chuck.
 For machines with automatically tool change mechanism:
 - The software open the collet chuck automatically.

➔ The collet chuck release the dummy tool.

3. Remove the dummy tool from the collet chuck.

◆ Now the circuit board plotter is ready for operation.

6 Operation

The following chapter describes the production processes which can be done with the circuit board plotter.

CircuitPro basic knowledge is required.

6.1 Production process

The production process has always **three** phases:

- | | |
|-----------|--|
| Phase I | System start

The circuit board plotter, the PC and the dust extraction have to be activated and the control software CircuitPro has to be started. |
| Phase II | Execute the processing steps

Corresponding to the requirements for production of the material the machining mode, e.g. manual drilling, manual milling or automatically operation has to be selected. During automatically mode the individual production phases are selected manually and will be executed by the circuit board plotter. |
| Phase III | System shut down

The control software CircuitPro has to be terminated and the circuit board plotter, the PC and the dust extraction must be switched off. |

6.2 Start system

Always proceed in the same sequence when starting the system.



Note

The dust extraction is connected to the circuit board plotter via a control cable and it is operating automatically. The dust extraction will be activated and deactivated by the circuit board plotter.

■ System start

1. Check all connection cables and tubes.
➔ Exchange damaged cables or tubes at once.
2. Open the soundproof hood of the soundproof housing.
3. Switch on the circuit board plotter by setting the main switch to position **1 (ON)**.
4. Start the PC.
5. Start **CircuitPro**.

➔ The **CircuitPro** start-up logo is shown:

Fig. 23: Startup image

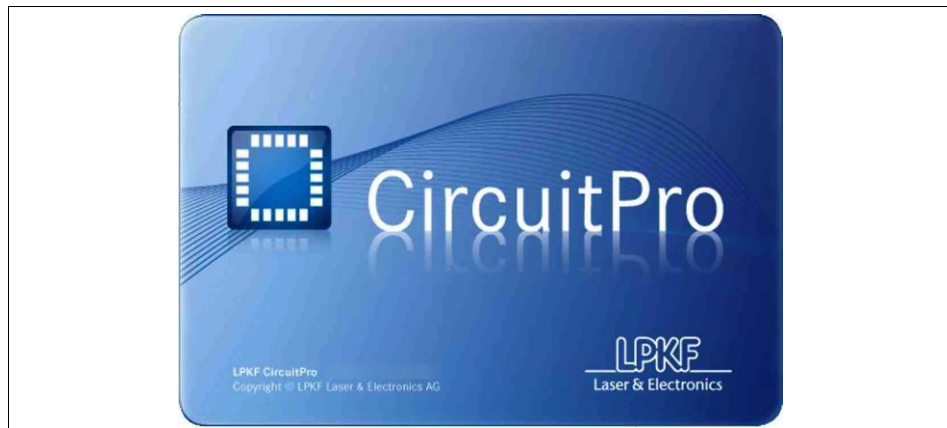

◆ **CircuitPro** starts and establish the connection to the circuit board plotter.

6.2.1 Tool status monitoring



Only printed board plotter with automatically tool exchange support this function.

Note

It is possible that the mill/drill head is equipped with a tool, used by a production process in the past. This tool can be ejected or must be placed into the tool magazine.

CircuitPro is checking the tool status:

- Tool status is known The tool will be placed into the corresponding position of the tool magazine.
- Tool status is unknown The tool will be ejected.

■ Eject tool



Only when switching on the first time and after the system installation.

Note

➔ When the connected circuit board plotter is detected by **CircuitPro** the following message is shown:

Fig. 24: Check active tool

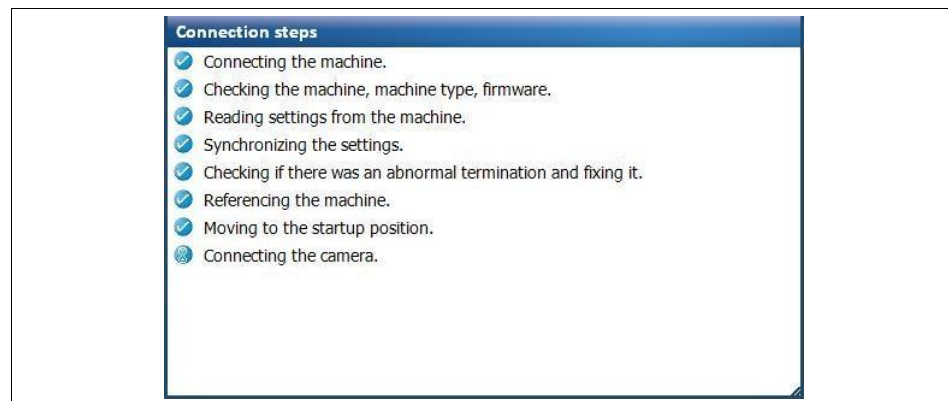

1. Click \1 ... 15\ or \None\ if no tool is clamped into the collet chuck.
2. Click on [Ok].

➔ The tool is placed corresponding tool magazine position.



The drill/mill head moves to the zero position, if the value "0" is entered in the input field \Tool holder ID\. The message "Open collet chuck" is shown. Click [OK] to eject the tool.

Note

◆ The tool is placed in the tool holder.

6.2.2 Graphical user interface

The *CircuitPro* user interface consists of several windows.

Fig. 25: User interface

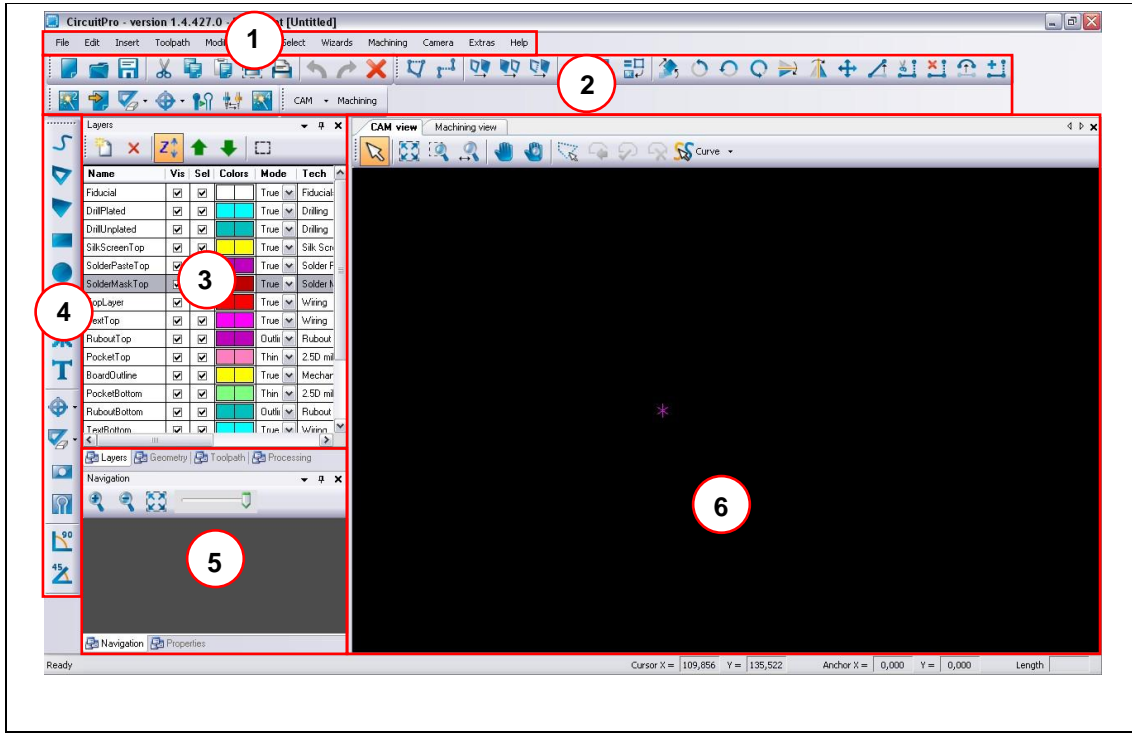

Tab. 9: User interface

Nr.	Display	Function
/1/	Menu bar	The individual program menus can be accessed via the menu bar.
/2/	Function bar	The function bar contains several functions for the control of the circuit board plotter and modification of the machining process.
/3/	Window Layer and Machining	The window "Layer" lists the individual project layers.
/4/	Function bar Object/Path processing	The function bar "Object/Path processing" contains several functions to edit or process individual objects or paths.
/5/	Window Navigation and Camera	The window "Navigation" displays the actual working area.
/6/	Window CAM and Machining View	The window "CAM View" shows the object data of the current project. All individual objects are highlighted in user defined colours.

6.2.2.1 Menu bar

The **CircuitPro** program functions can be accessed via the menu bar.

Fig. 26: Menu bar

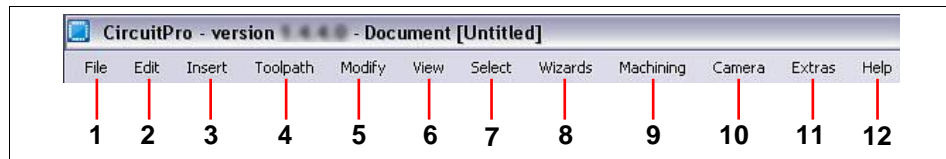

- | | |
|-------------------|--------------------|
| /1/ Menu File | /7/ Menu Select |
| /2/ Menu Edit | /8/ Menu Wizards |
| /3/ Menu Insert | /9/ Menu Machining |
| /4/ Menu Toolpath | /10/ Menu Camera |
| /5/ Menu Modify | /11/ Menu Extras |
| /6/ Menu View | /12/ Menu Help |

Tab. 10: Menus

Menu	Short description
File	The menu "File" provides program functions to open, store, import and export work files.
Edit	The menu "Edit" provides program functions to create work data as well as files, e.g. placing of new objects on the base material.
Insert	The menu "Insert" provides program functions to insert tool paths or work areas.
Toolpath	The menu "Toolpath" includes the functions isolate tool path and process contours.
Modify	The menu "Modify" offers program functions to process tool paths.
View	The menu "View" allows the operator to activate/deactivate the possible program windows.
Select	Use the functions of the menu "Select" to select certain zones of the working area.
Wizards	The menu "Wizards" is using to open several wizards.
Machining	Use the functions of the menu "Operate" to control the machining process.
Camera	The menu "Camera" offers program functions to set the installed camera.
Extras	The menu "Extras" offers functions to customize CircuitPro.
Help	The menu "Help" gives information about this program.

6.2.2.2 Function bar

Fig. 27: Function bar

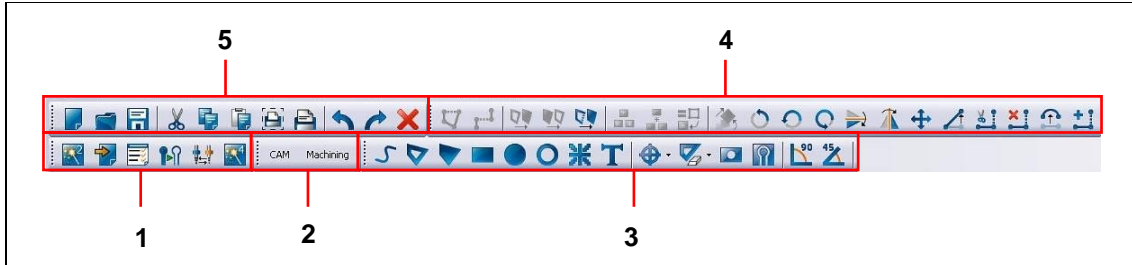

/1/ Processing functions

/4/ Toolpath functions

/2/ Views

/5/ File operating functions

/3/ Object processing

Tab. 11: Function bars

Function	Description
Processing functions	General processing functions like starting the wizards, tool change operations and isolate operations.
View	Change-over the mains window by switching between CAM and Machining view.
Object processing	General object editing and processing functions.
Toolpath functions	General functions to edit or process a tool or processing path.
File operating functions	General operating functions like Undo, Redo, Cut, Copy an Insert.

6.2.3 Window Processing

The connected circuit board plotter is controlled via the menu window "Processing":

Fig. 28: Window Processing

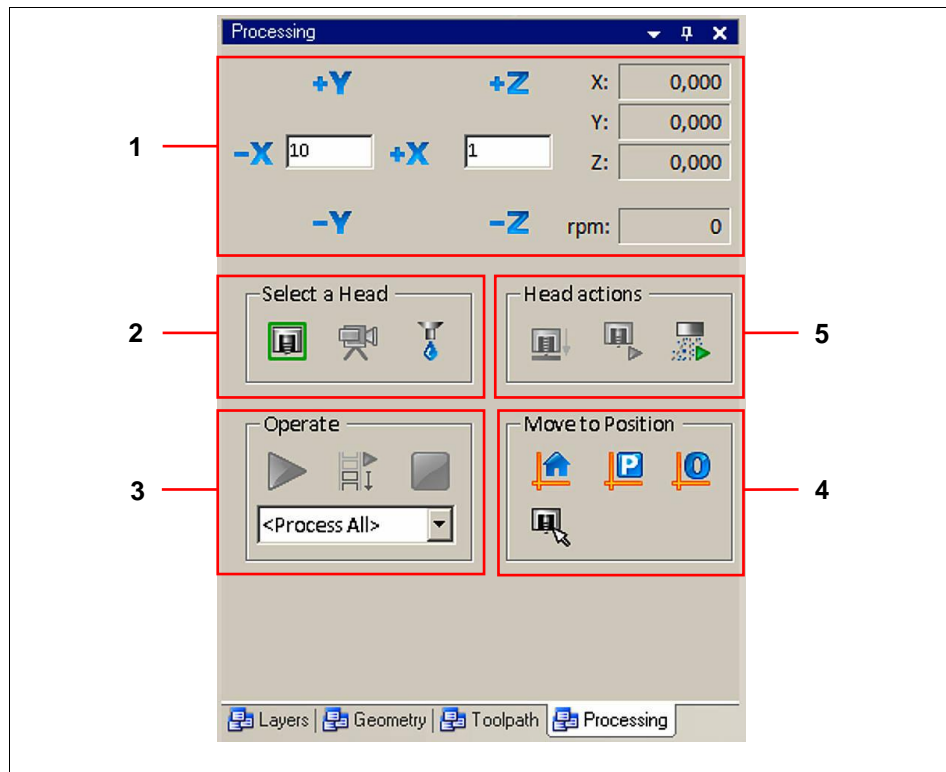

/1/ Mill/drill head manual control functions

/4/ Moving the mill/drill head to determined positions

/2/ Select head (mill/drill head, camera or dispenser)

/5/ Mill/drill head control (for example Motor on/off)

/3/ Processing functions (for example Start, Stop or Step/Repeat)

6.2.3.1 Manual control of the mill/drill head

Fig. 29: Control of mill/drill head

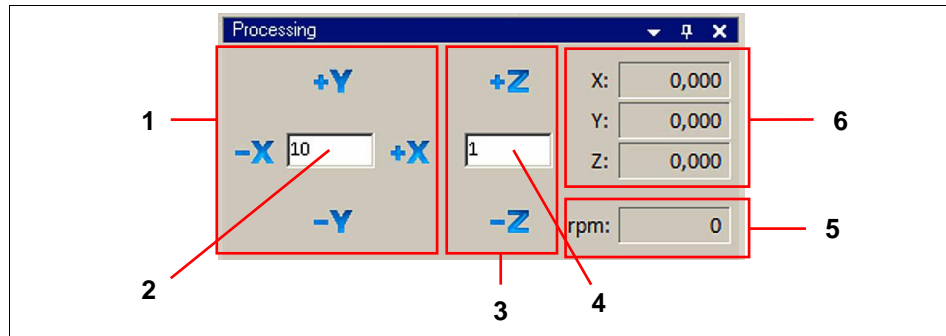

/1/ Manual control X/Y direction

/2/ Input field \X/Y step range\

/3/ Manual control Z direction

/4/ Input field \Z step range\

/5/ Output field \Motor speed\

/6/ Display X/Y/Z coordinates

The individual buttons have the following functions:

No.	Description
/1/, /2/	Type a value into the entry box \X/Y step size\ and click [-X] to move the mill/drill head to the left side or click [+X] to move the mill/drill head to the right side. Type a value into the input field \X/Y step size\ and click [-Y] to move the mill/drill head forward or click [+Y] to move the mill/drill backward.
/3/, /4/	Type a value into the input field \X/Y step size\ and click [-Z] to lift down the mill/drill head or click [+Z] to lift up the mill/drill head.
/5/	The output field \rpm:\ displays the current spindle rotation speed of the mill/drill head.
/6/	The output fields \X:\, \Y:\ and \Z:\ show the current position of the mill/drill head.

6.2.3.2 Select head

Fig. 30: Select head

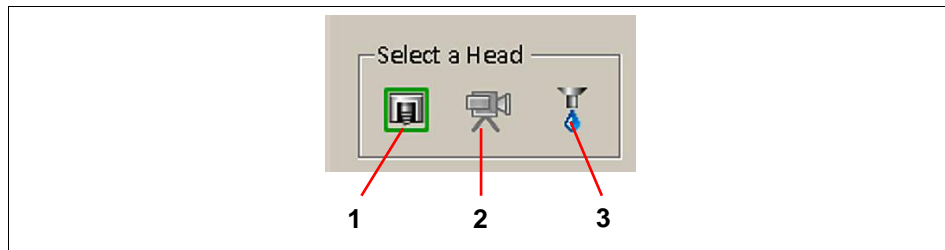

/1/ Mill/drill head

/3/ Dispenser

/2/ Camera

The individual buttons have the following functions:

No.	Description
/1/	Click on [Mill/drill head] to move the reticle (positioning indicator) of the machining view onto the current mill/drill head position. The mill/drill head will be repositioned accordingly.
/2/	Click on [Camera] to move the reticle (positioning indicator) of the machining view onto the current camera position. The mill/drill head will be repositioned accordingly.
/3/	Click on [Dispenser] to move the reticle (positioning indicator) of the machining view onto the dispenser position. The mill/drill head will be repositioned accordingly.



Note

The icons for camera and dispenser are deactivated when the components are not installed (for example **ProtoMat S43**).

6.2.3.3 Operate

Fig. 31: Operate

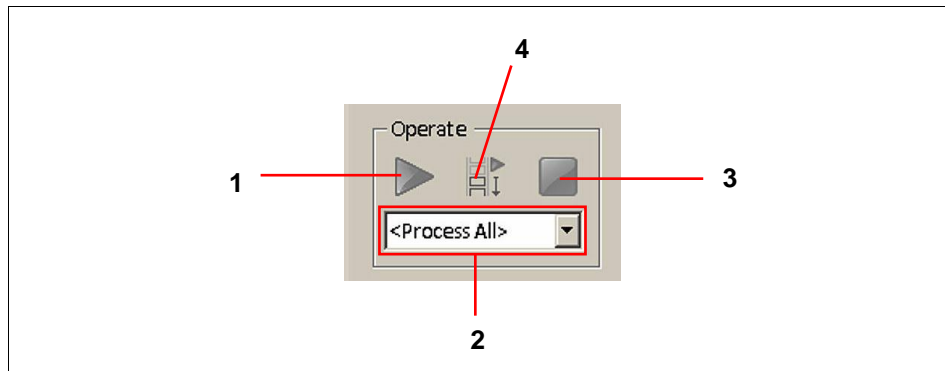

/1/ Start processing

/3/ Stop processing

/2/ Selection field \Phase\

/4/ Step and repeat

The input field has the following function:

No.	Description
/2/	Click on the selection field \Phase\ and select a processing phase.

The individual buttons have the following functions:

No.	Description
/1/	Click [Start processing] to start the complete machining process.
/3/	Click [Stop processing] to stop the current machining process.
/4/	Click [Step and repeat] to continue the machining process.

6.2.3.4 Move to Position

Fig. 32: Move to Position

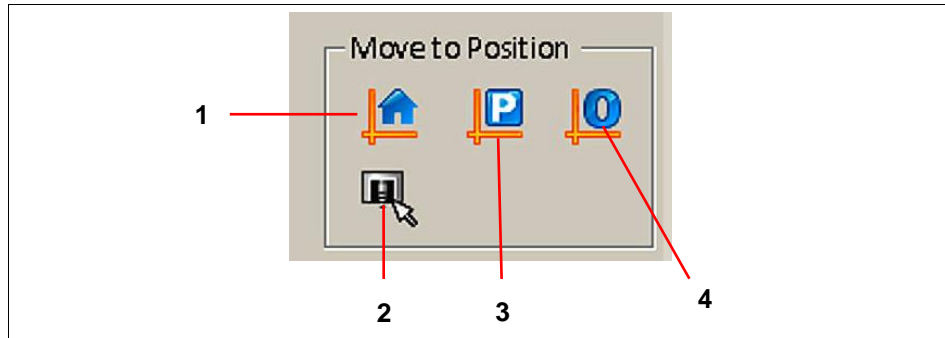

/1/ Home position

/3/ Pause position

/2/ Move by mouse position

/4/ Zero position

The individual buttons have the following functions:

No.	Description
/1/	Click [Home Position] to move the mill/drill head to the home position.
/2/	Click [Move by mouse position] and the mill/drill head follows the current mouse position.
/3/	Click [Pause Position] to move the mill/drill head to the pause position.
/4/	Click [Zero Position] to move the mill/drill head to the zero position (reference point).

6.2.3.5 Head actions

Fig. 33: Head movement

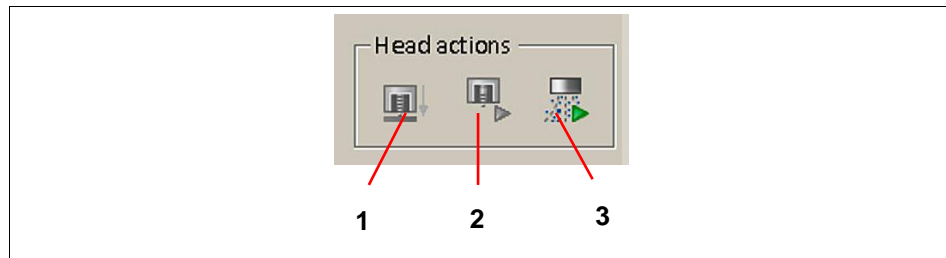

/1/ Lift mill/drill head up/down

/3/ Dust extraction unit on/off

/2/ Motor on/off

The individual buttons have the following functions:

No.	Description
/1/	Click [Lift head up/down] to lower the mill/drill head.
/2/	Click [Motor on/off] to start or stop the motor. The symbol changes correspondingly from a green triangle (90° position) to a red rectangle.
/3/	Click [Exhaust unit on/off] to activate/deactivate the dust extraction unit by the operator. The symbol changes correspondingly from a green triangle (90° position) to a red rectangle.

6.3 Establish a connection

As a first step a connection between the PC and the circuit board plotter has to be established.

■ Establish a connection

1. Go to the menu "Machining" and click "Connect...".

Fig. 34: Select circuit board plotter

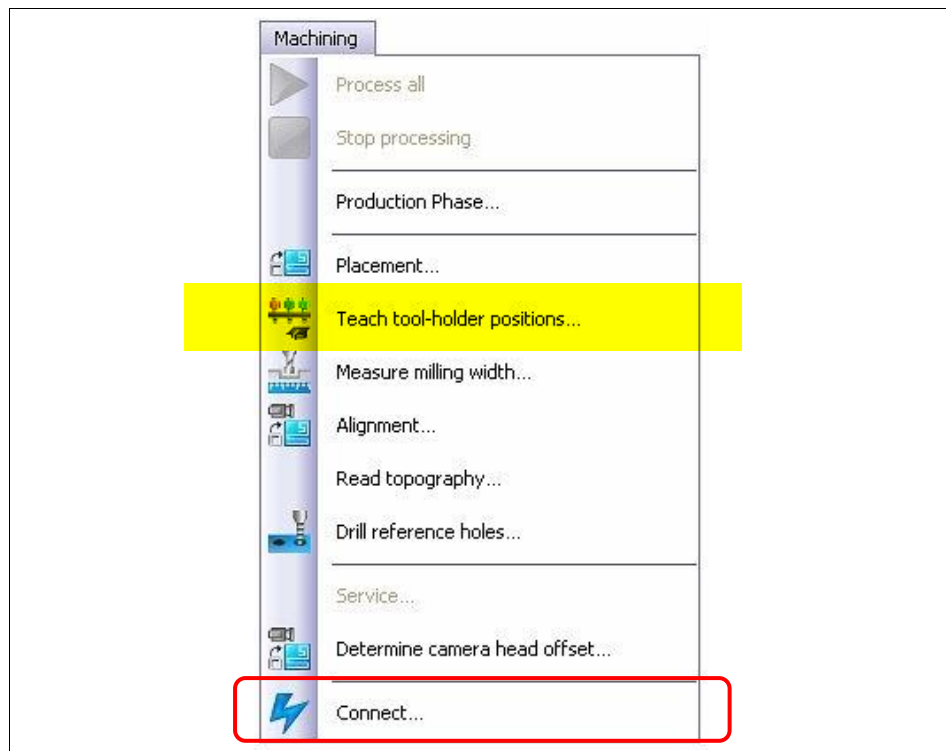

➔ The following window is shown:

Fig. 35: Connect



2. Click on the selection box \Machine type\ and select the type of the connected machine.
 3. Click [Connect].
- ➔ The connection to the circuit board plotter is established and the following message appears:

Fig. 36:
Connection

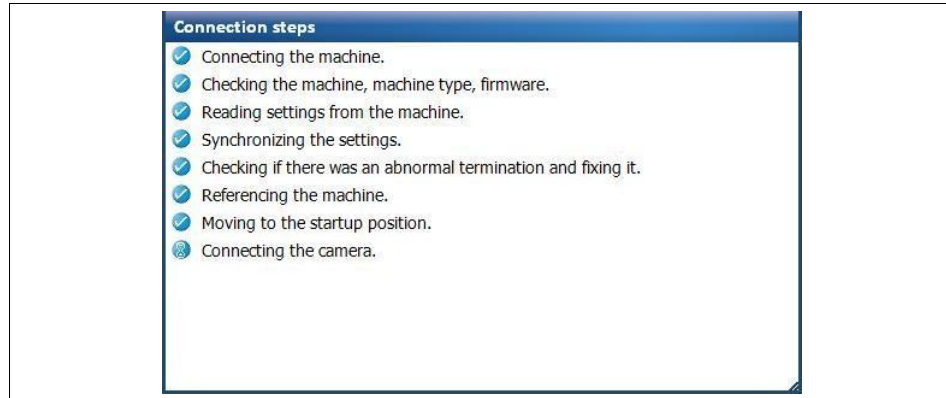

4. Click on the selection field \Tool position\ and select a tool number.
 5. Click on [OK] to confirm the chosen tool position.
- ➔ After the circuit board plotter was detected and its data will be transmitted, the **CircuitPro** user interface opens:

Fig. 37: User
interface

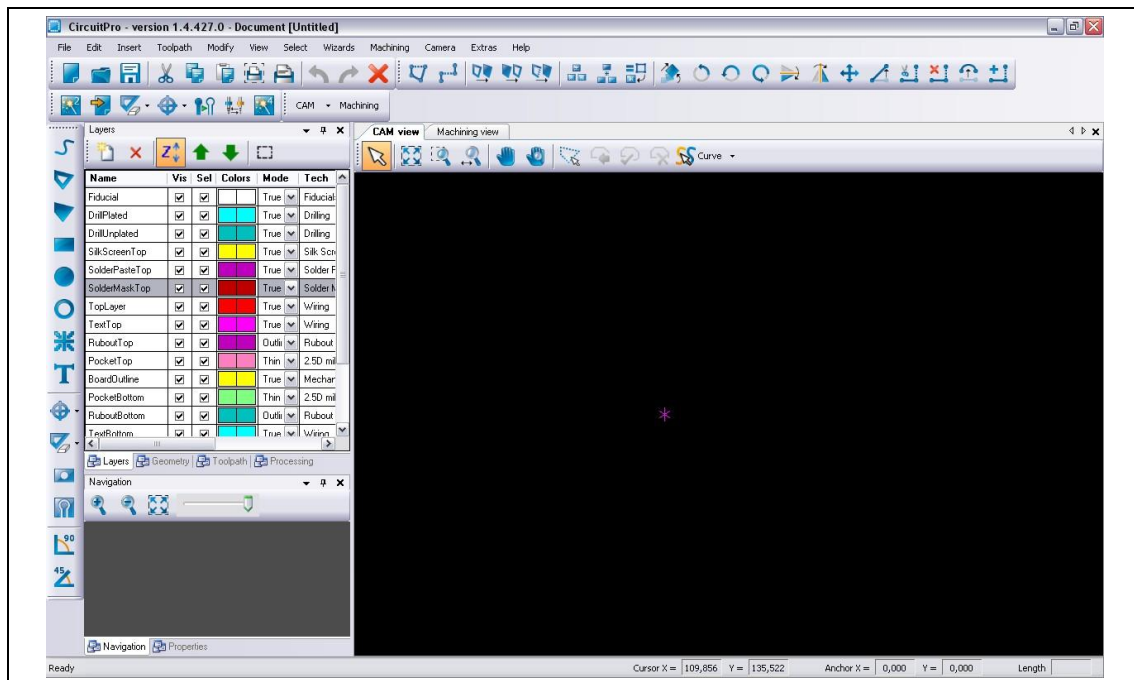

Note

The tool magazine will be not displayed if a printed circuit board plotter without automatically tool change mechanism is connected.

- ◆ Now the circuit board plotter is ready for operation.

6.4 Place material

Before any machining process starts the material has to be placed and fixed on the work or vacuum table.

6.4.1 Worktable

■ Fix the production material

Fig. 38: Control

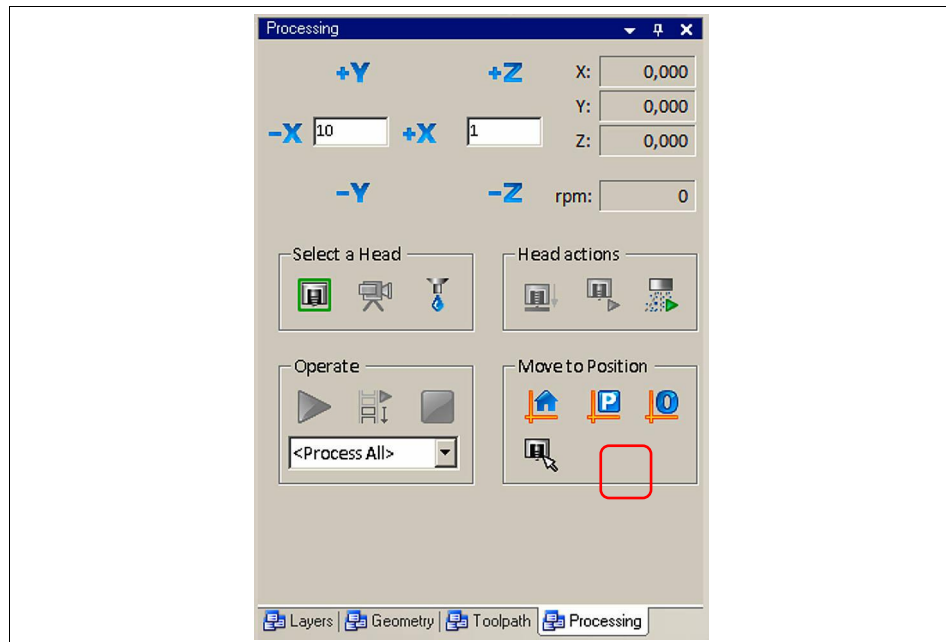

1. Click on [Pause position].
 - ➔ The mill/drill head moves to pause position.
2. Open the soundproof hood.
3. Clean the working table and remove material rests with a smooth paint brush or a slightly damp cloth.
4. Place the underlay on the work table. The pivots must be fit into the reference holes of the underlay.
5. Place the production material on the underlay in a way that the pivots fit into the reference holes.
6. Check the production material. The head of the reference hole pivots must be lower than the production material surface.

For machines without vacuum table:
7. Fix the production material with a tape on the underlay. The tape has to be removable without remains. The tape must be guided alongside the edges of the production material.
 - ◆ The production material is fixed.

6.4.2 Vacuum table

■ Fix the production material

Fig. 39: Control

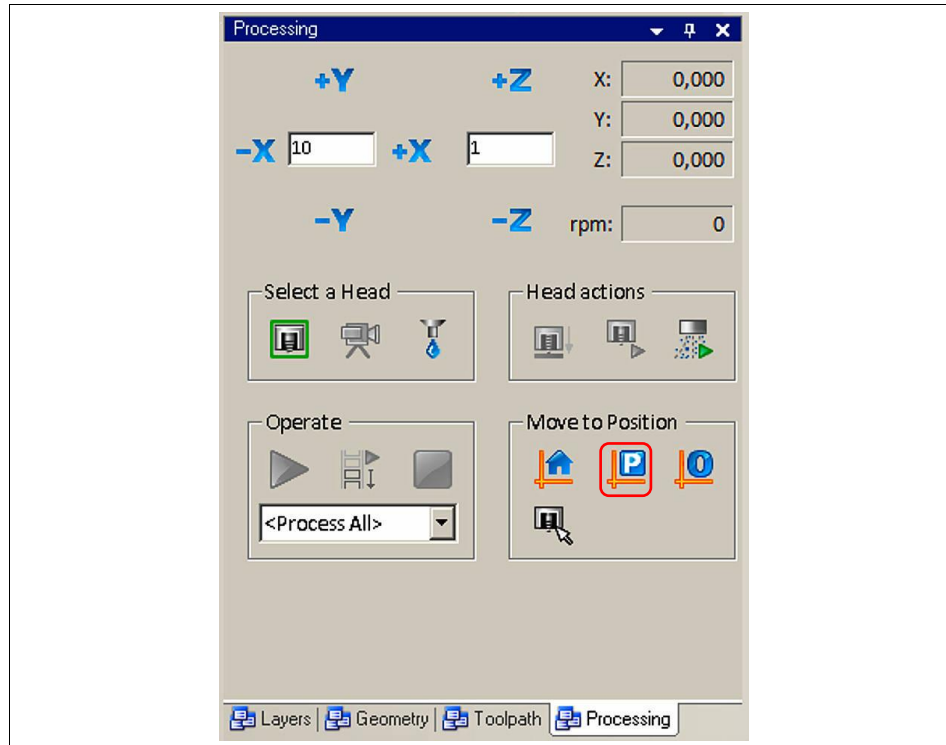

1. Click on [Pause position].
 - ➔ The mill/drill head moves to pause position.
2. Open the soundproof hood.
3. Clean the vacuum table and remove material rests with a smooth paint brush or a slightly damp cloth.
4. Place the underlay on the working table so that the pivots fit into the reference holes.
5. Place the production material on the vacuum table.
 - ◆ The production material is placed on the vacuum table and will be fixed when the production process starts.

6.5 Tool setup



Note

Any change of tools is performed manually for circuit board plotters without tool exchange appliance. These machines will be delivered **without** tool magazine.

6.5.1 Manual tool change procedure

According to the individual project requirements the tools must be changed manually if the used machine is not equipped with a tool magazine and do not support the automatically tool change procedure.

■ Insert tool

1. Click on [Change tool].

Fig. 40: Tool change



- ➔ The following window is displayed:

Fig. 41: Tool settings

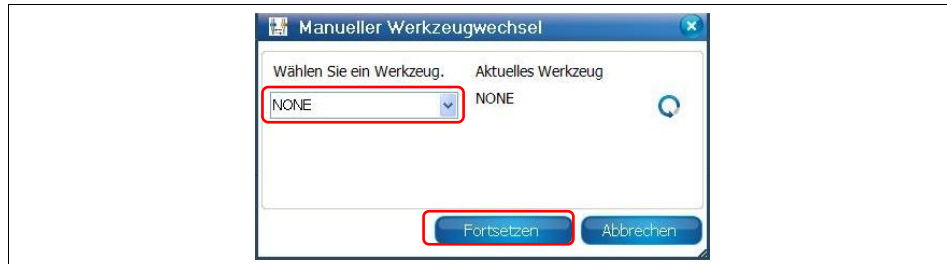

2. Take the tool gripper and insert the required tool.
3. Open the collet chuck by turning the rotary knob of the mill/drill head.
4. Insert the tool into the collet chuck.
5. Close the collet chuck by turning the rotary knob of the mill/drill head and place the tool gripper aside.
6. Click into the field \Select tool\ and edit the new tool.
7. Click on [Continue].

- ◆ The tool is configured.

6.5.2 Automatically tool change process

The tool magazine of the circuit board plotter can house up to **15** different tools. The position of each tool is displayed in the window "Machining view".

Fig. 42:
Machining view

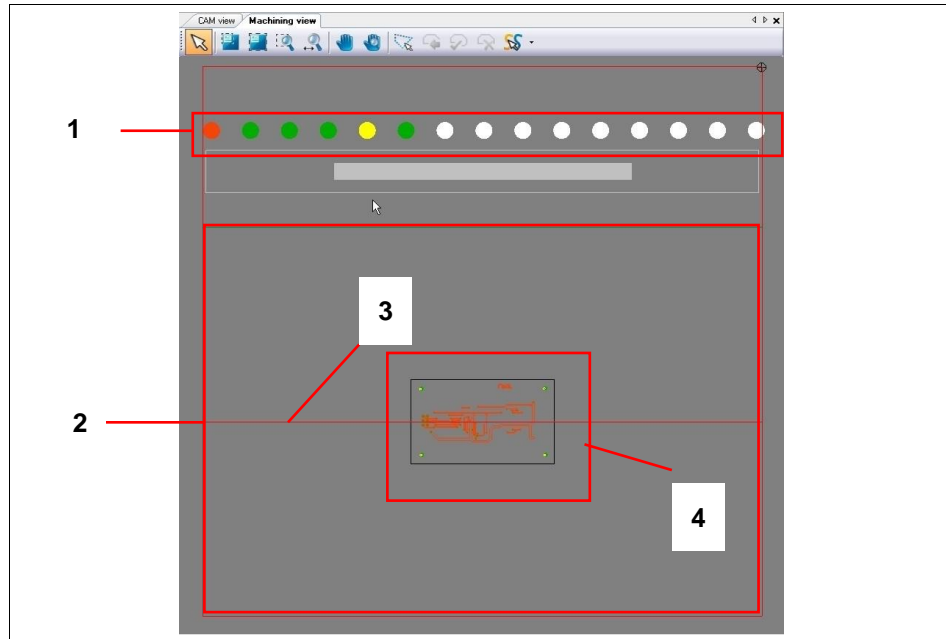

/1/ Tool position

/2/ Machining area

/3/ Axis of reflexion

/4/ Current project data

■ Tool setup

Fig. 43: Insert tool

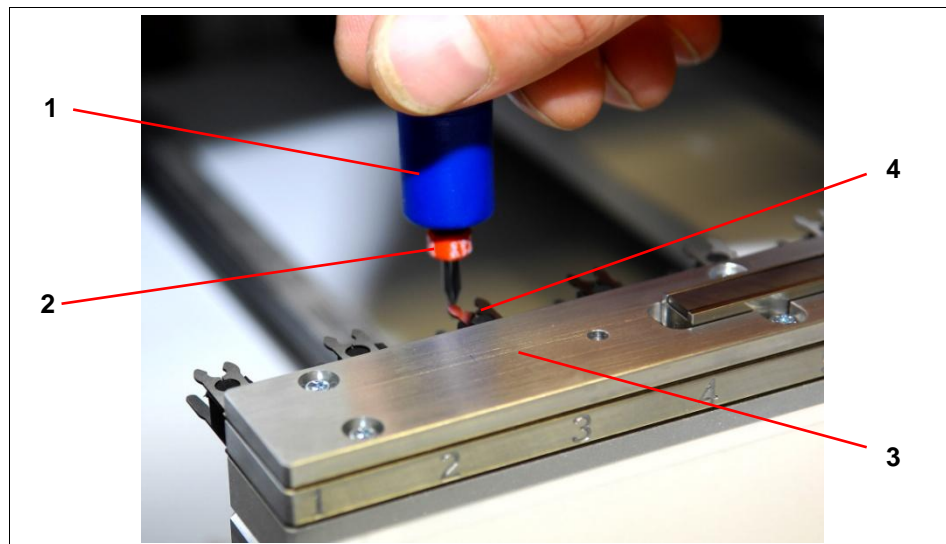

/1/ Tool gripper

/2/ Tool

/3/ Tool magazine

/4/ Tool clamp

1. Take the tool gripper /1/ and insert a tool /2/.
2. Place the tool into a free position of the tool magazine /3/.
3. Click [Change tool].

Fig. 44: Tool exchange



➔ The following window is displayed:

Fig. 45: Tool setup

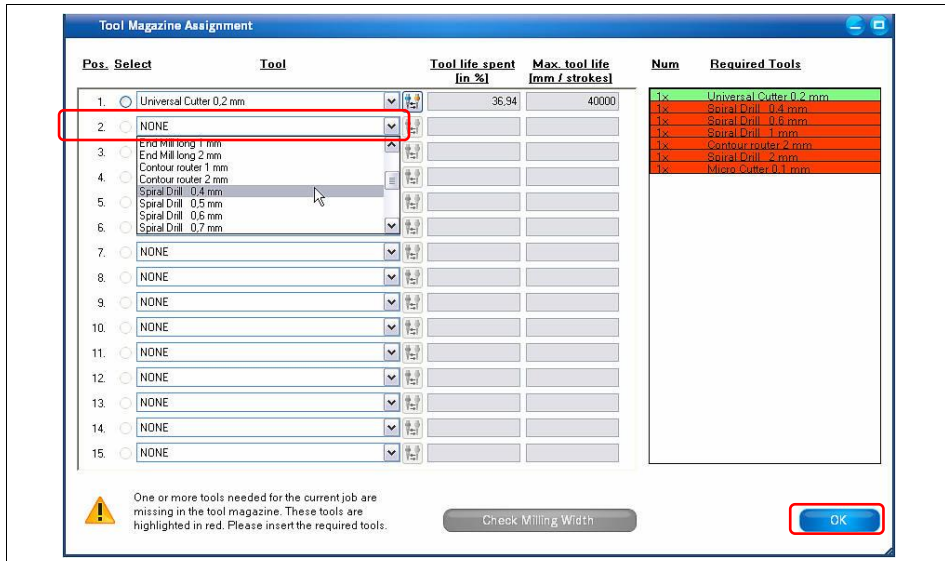

4. Select a free position of the entry field \Tools\ and specify the tool.



A selection of required tools for the current project can be found in the list "Required Tools".

Note

5. Click [OK].

◆ Now the tool is configured.

6.5.3 Tool colour code

All LPKF tools are equipped with a distance ring, colour coded accordingly to the tool applications:

Tab. 12: Tool colour coding

Colour	Tool application
Red	MicroCutter
Orange	UniversalCutter
Blue	EndMill (RF)
Purple	EndMill
Olive-green	EndMill (long)
Yellow	ContourRouter
Green	SpiralDrills

The tool position display of the window “machining view” is corresponding to the colour coding definitions:

Tab. 13: Tool position display code

Display	Definition
Filled colour circle	The tool position is equipped with a mill or drill tool. The displayed colour is according to the tool application (see Tab. 12: Tool colour coding)
Unfilled colour circle	The tool position is equipped with a mill or drill tool. The tool is placed in the collet chuck of the machine.
White circle	The tool position slot is not assembled
Black circle	The tool position is not configured.

Example:

Fig. 46: Tool holder

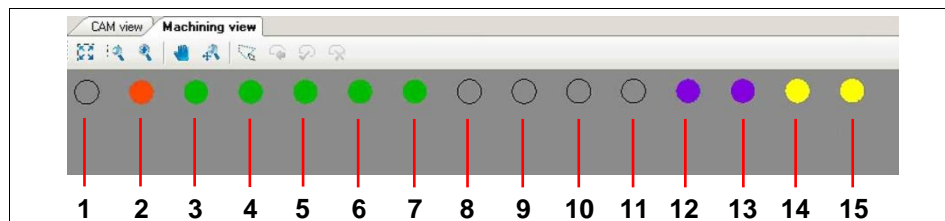

/1/ not configurated
 /2/ MicroCutter
 /3/ SpiralDrill
 /4/ SpiralDrill
 /5/ SpiralDrill
 /6/ SpiralDrill
 /7/ SprialDrill
 /8/ not configurated

/9/ not configurated
 /10/ not configurated
 /11/ not configurated
 /12/ EndMill
 /13/ EndMill
 /14/ ContourRouter
 /15/ ContourRouter

6.6 Manual drilling



Note

Every individual tool for the PCB production must be clamped into the mill/drill head manually, if a circuit board plotter **without** automatic tool change function is used.

For the process “manual drilling“ the corresponding drill is inserted into the collet chuck of the mill/drill head and the drilling position will be reached via mouse movement. The motor is activated/deactivated by a clicking the start button as well.



Note

The available tools allow the drilling of round holes with a max. diameter of **3 mm**.



ATTENTION

Health hazard caused by fine particles and gases!

During the machining process for work pieces harmful fine particles and gases may occur which can be inhaled!

Make sure that the dust extraction is activated during machining of the work piece. Be sure to use fine particle filters exclusively.



ATTENTION

Risk of injury by burning!

During the machining process the used tools and the collet chuck are heating up, a direct skin contact may cause burnings.

Wear protective gloves and tweezers for manual change of tools during operation.



ATTENTION

Risk of injury by sharp edges!

The used tools are sharp-edged and cause cut or stab wounds when used improperly.

Store the tools always in the toolbox and secure the toolbox against unauthorised utilisation.

■ Produce a drill hole

1. The preparative activities are described in detail on page 67.

➔ The PCB material is fixed on the working table.

Fig. 47:
Machining view
select tool

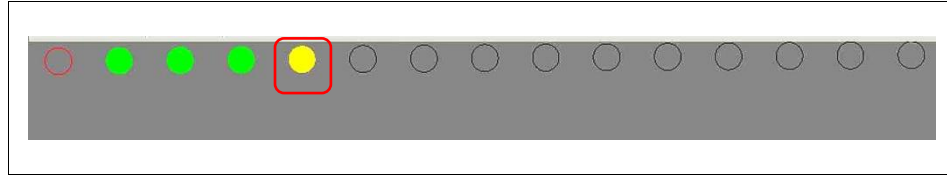

2. Move the mouse to the tool position bar, located in the upper edge of the window machine view and select a tool.

ProtoMat S43: Insert a tool into the collet chuck of the mill/drill head.

3. Move the mill/drill head to the start position:

Fig. 48: Adjust
position

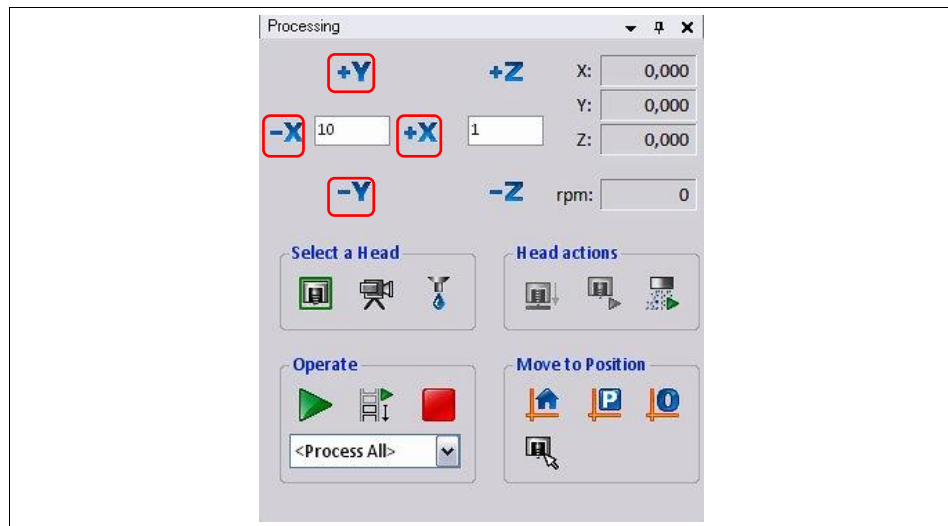

4. Type a value into the input field \X/Y step size\ and click[+X], [-X], [+Y] or [-Y] until the drilling position is reached.

The exact position is displayed in the output fields \X:\ and \Y:\.

Fig. 49: Control
milling/drilling
head

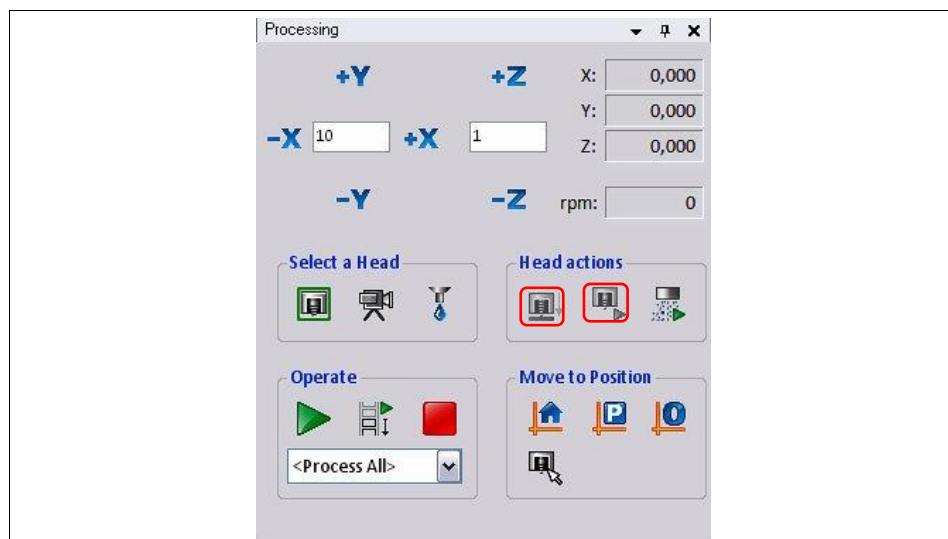

5. Click on [motor on/off].
 - ➔ The drilling spindle rotates and the dust extraction is activated.
6. Click on [Lift head up/down].
 - ➔ The mill/drill head is lowered and the corresponding drilling hole is created.
After this process the mill/drill head returns to the rest position.
7. Click on [Motor on/off].
 - ➔ The drilling spindle stops and the dust extraction is deactivated.
8. Repeat steps 3 to 6 if you wish to create further drilling holes.
 - ◆ The drilling hole is created.

6.7 Manual milling



Note

Every individual tool for the PCB production must be clamped into the mill/drill head manually, if a circuit board plotter **without** automatic tool change function is used.

For the process “manual milling“ the milling tool has to be inserted into the collet chucks of the mill/drill head. The mill/drill head will be moved to start position and then the motor is to be started. Afterwards the mill/drill head is lift down and the milling track will be accessed. The milling depth is adjusted automatically.

The production result depends directly on the depth of penetration of the used milling tool. An insufficient material removal between the PCB tracks may cause malfunctions of the printed circuit board. For the conical milling tools like UniversalCutter and MicroCutter the milling depth is determinate by the depth of penetration of the milling tool.

Always mill a test track on the PCB material and check the milling depth using a measuring microscope. Change the milling depth setting if required and repeat the milling process until you have the correct result.



Note

By using the milling depth limiter the depth of penetration can be adjusted in **2 µm** steps until the exact result has been reached.



ATTENTION

Health hazard caused by fine particles and gases!

During machining process of work pieces harmful fine particles and gases may occur which can be inhaled!

Make sure that the dust extraction is activated during machining of the work piece. Be sure to use fine particle filters exclusively.



ATTENTION

Risk of injury by burning!

During the machining process the used tools and the collet chuck heat up, direct contact may cause burnings.

Wear protective gloves and tweezers for manual change of tools during operation.



ATTENTION

Risk of injury by sharp edges!

The used tools are sharp-edged and cause cut or stab wounds when used improperly.

Store the tools always in the toolbox and secure the toolbox against unauthorised utilisation.

■ Manual setting of milling depth



Note

Only for circuit board plotters with manual setting of the milling depth the milling depth has to be adjusted using a micrometer screw.

1. Preparative activities are described in detail on page 67.

➔ The PCB material is fixed on the working table.

Fig. 50: Mill/drill head

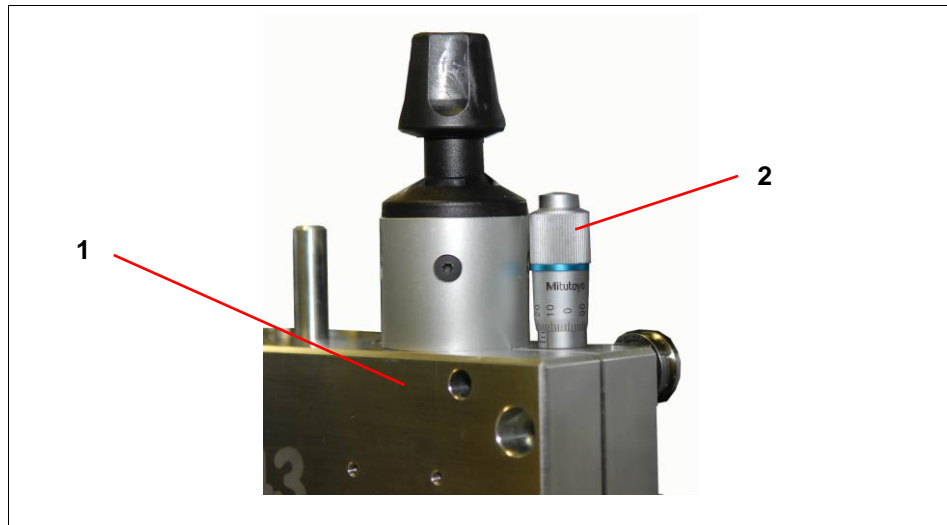

/1/ Drill/Mill head *ProtoMat S43*

/2/ Micrometer screw

2. Adjust the milling depth with the micrometer screw /2/.
3. Produce a test track.
4. Check the result using a measuring microscope.

Fig. 51: Optimal milling depth

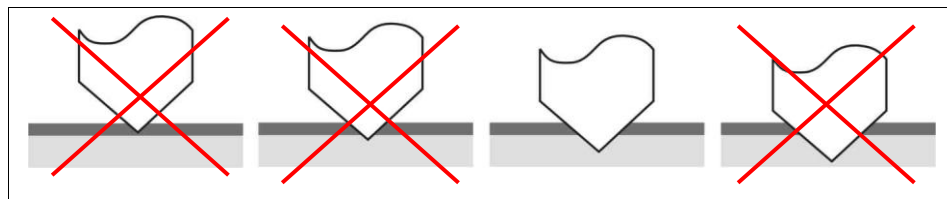

5. Repeat the process in necessary until a sufficient amount of material has been removed.

◆ The milling depth is now adjusted.

■ Produce a milling track

1. Preparative activities are described in detail on page 67.

➔ The PCB material is fixed on the working table.

Fig. 52:
Machining view
select tool

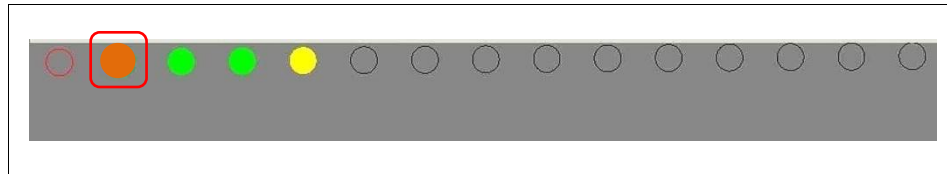

2. Select a milling tool.

ProtoMat S43: Open the collet chuck and place a milling tool into the tool holder.

3. Move the mill/drill head to start position:

Fig. 53: Set
position

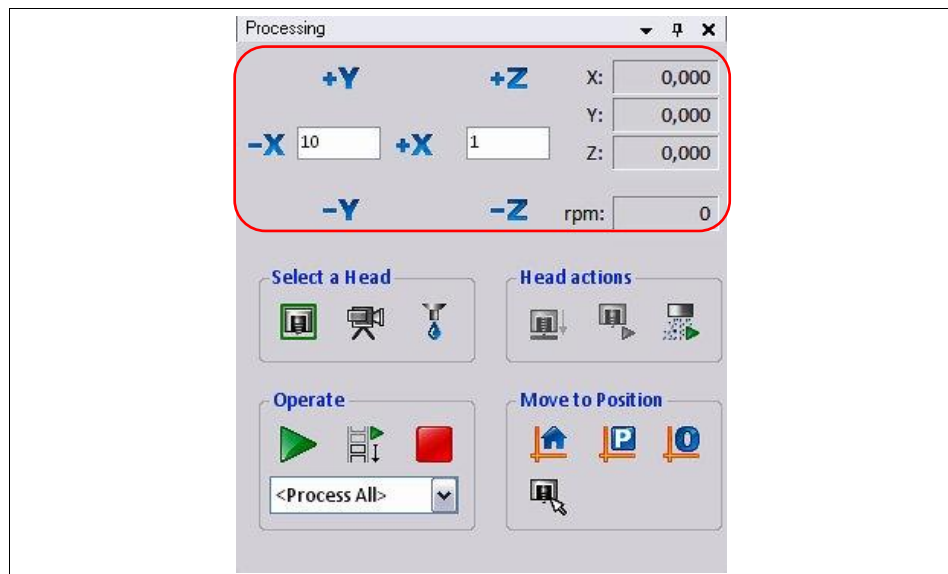

4. Click [+X], [-X], [+Y] or [-Y] until the start position is reached.

The exact position is displayed in the output field \X:\ and \Y:\.

Fig. 54:
Milling/drilling
head control

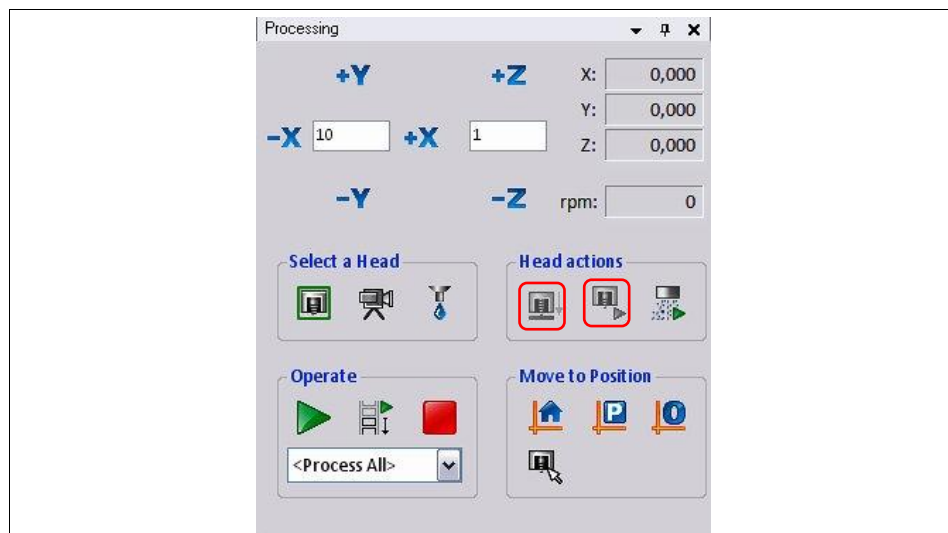

5. Click on [Motor on/off].
 - ➔ The drilling spindle rotates and the dust extraction is activated.
6. Click on [Lift head up/down].
 - ➔ The mill/drill head is lowered according to the milling depth setting.
7. Click [+X], [-X], [+Y] or [-Y] until the final position is reached.
 - ➔ Now the milling track is produced.
8. Click on [Lift up/down head].
 - ➔ The mill/drill head will be lift up.
9. Click on [Motor on/off].
 - ➔ The drilling spindle stops and the dust extraction will be deactivated.
10. For further milling tracks you have to repeat the steps 3 to 8.
 - ◆ Now the milling path is produced.

6.8 Automatic mode



Note

Every individual tool for the PCB production must be clamped into the mill/drill head manually, if a circuit board plotter **without** automatic tool change function is used.

During automatic operation single or multilayer PCBs are produced semi-automatically. According to the prepared CBF file the tools are selected and the drill holes and milling paths are produced.



ATTENTION

Health hazard caused by fine particles and gases!

During machining of work pieces harmful fine particles and gases may occur which can be inhaled!

Make sure that the dust extraction is activated during machining of the work piece. Be sure to use fine particle filters exclusively.



ATTENTION

Risk of injury by burning!

During the machining process the used tools and the collet chuck heat up, direct contact may cause burnings.

Wear protective gloves and tweezers for manual change of tools during operation.



ATTENTION

Risk of injury by sharp edges!

The used tools are sharp-edged and cause cut or stab wounds when used improperly.

Store the tools always in the toolbox and secure the toolbox against unauthorised utilisation.

6.8.1 Specify production type

Production data is assembled using the “Process planning wizard”.

■ Generate production data

Fig. 55: Start wizard

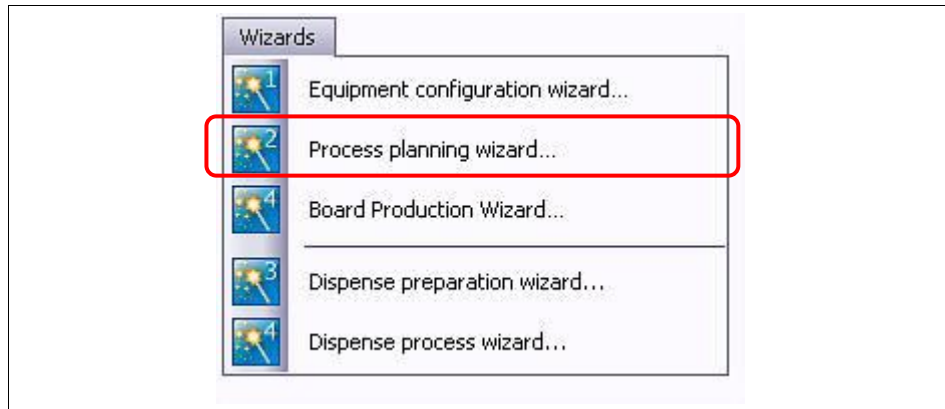

1. Click Wizards>Process planning wizard....

➔ The following window is shown:

Fig. 56: Process planning wizard

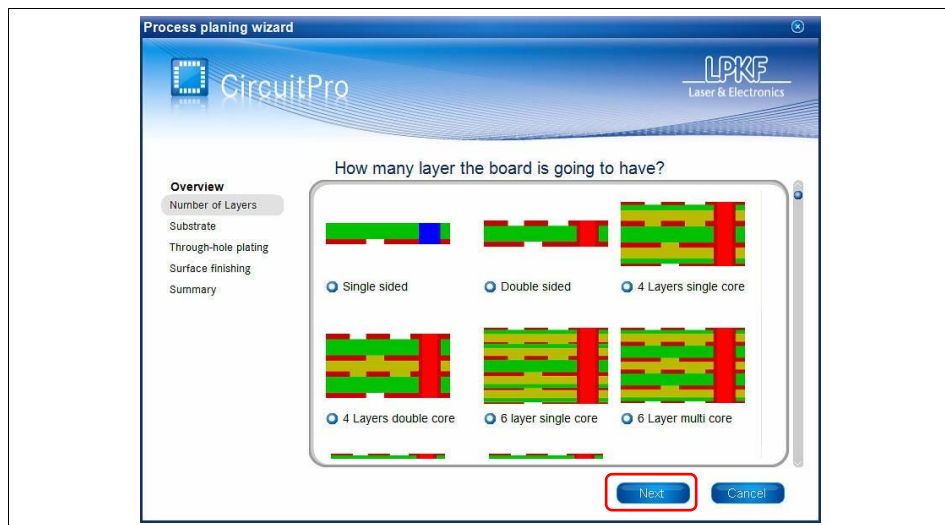

2. Edit the required setting for the production process and click [Next].

3. Follow the instructions of the assistant.

➔ If all settings have been made the following window is shown:

Fig. 57: Summary

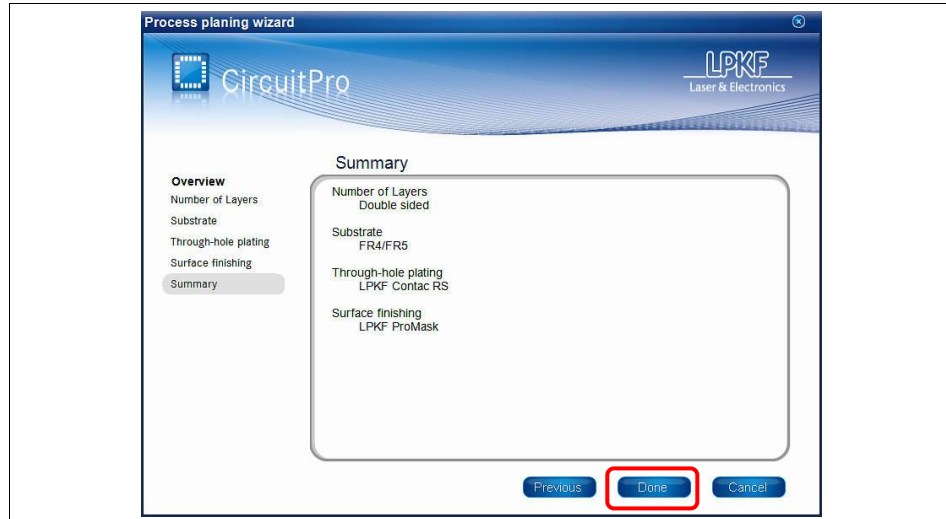

4. Click [Done] and the window will be closed.

◆ Now the production process is configured.

6.8.2 Loading the CBF file

A CBF file contains all data required for the production of printed circuit boards. You can either open an existing CBF file to rework it or create a new file.



CircuitPro processes always one CBF file. Whenever you open a additional file, all data is overwritten.

Note

■ Open a CBF file

1. Click File>Open.

➔ The window “Open” is shown:

Fig. 58: Window Open

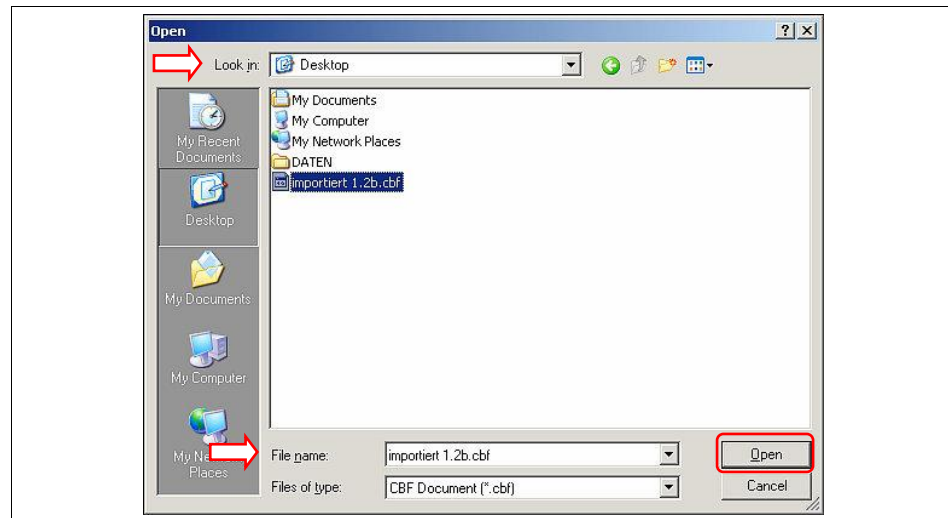

2. Click the selection field \Search in:\ and select a destination folder.

3. Click on the CBF file.

➔ The file name appears in the selection field \File name\.

4. Click [Open].

➔ The CBF file is loaded and the projects contained are placed on the working area.

Fig. 59: Working area

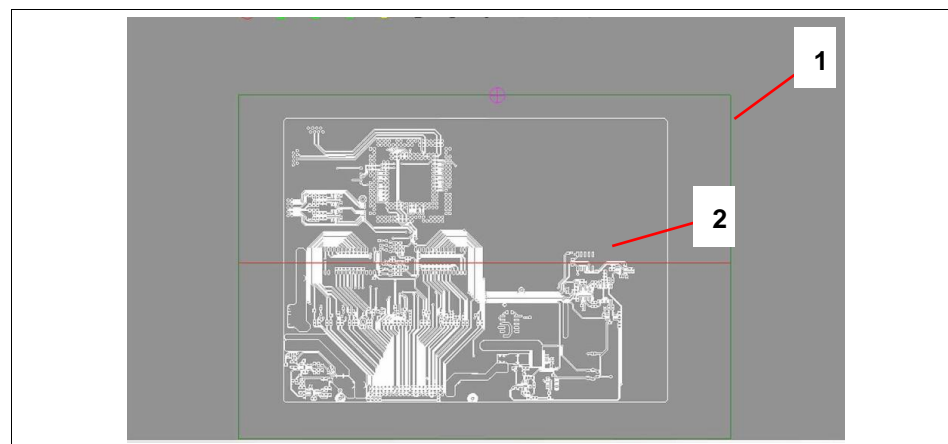

/1/ Working area

/2/ Printed circuit board

◆ Now the CBF file is loaded.

6.8.2.1 Production of the printed circuit board

The production process can start when all settings for the PCB production have been entered completely.

■ Production process

Fig. 60: Start wizard

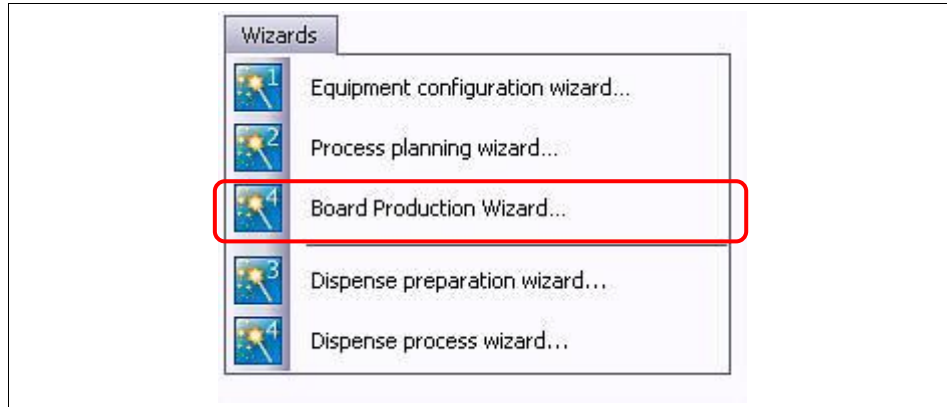

1. Click Wizard>Board Production Wizard.

➔ The following window is shown:

Fig. 61: Process planning wizard



2. Follow the instructions and click [Start].

➔ The next production step is shown.

3. Follow the instructions and click [Next].

➔ The PCB production is finished, when all productions steps a run through and the following window is shown:

Fig. 62: Process planning wizard

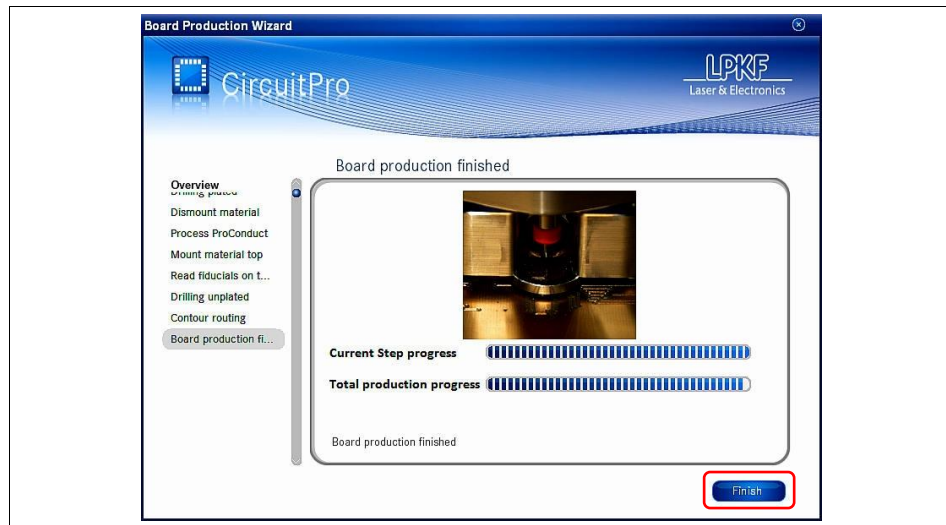

4. Click [Finish] to stop the board production process.
 5. Demount the board.
 6. Clean the board and make a visual check.
- ◆ The board production is finished.

6.9 Dispense

The dispense device is used to apply solder paste on the printed circuit board before the placement of SMD parts starts. With compressed air the solder paste will be applied point by point with precision and in small quantity. Also applying SMD glue or other materials which can be filled into cartridges is called dispensing.



Note

The dispensing device is included in the delivery for all mill/drill plotters with automatic tool change function.

The dispense set consists of:

Fig. 63: Complete dispense set

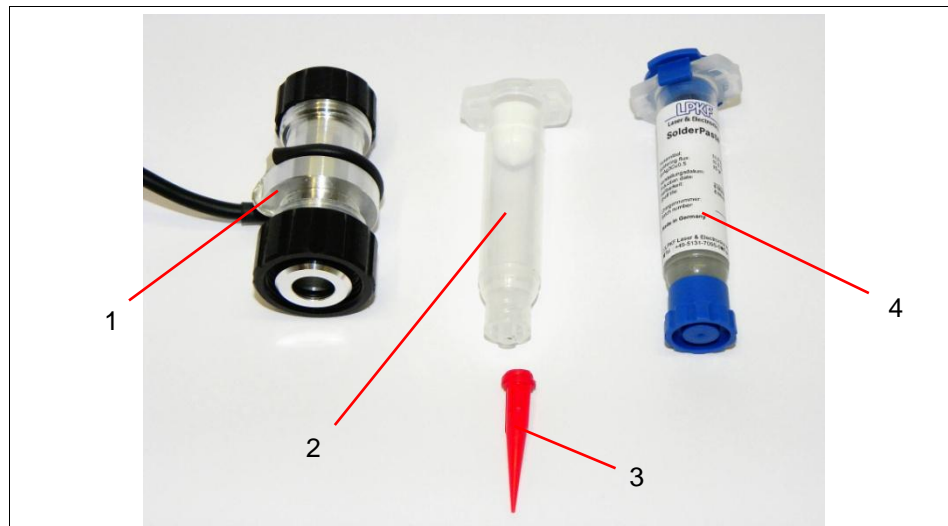

/1/ Dispense adapter

/2/ Empty cartridge

/3/ Dispensing tip

/4/ **Solder Paste** cartridge



Note

The solder paste is not included in the scope of delivery and must be ordered separately.

6.9.1 Mount dispense set



Note

Keep the solder paste stored in a cool place until consumption. Before starting the dispense process the solder paste must be warmed up to room temperature.



Note

The installation of the dispense set will be guided by an intuitive wizard. Start the installation of the dispense set when requested by the wizard.

■ Assembling the dispense set

Fig. 64: Dispense adapter



1. Take the dispense adapter and loosen the upper fastening nut $\frac{1}{3}$. Pull out the empty cartridge.
2. Take the empty cartridge and unscrew the dispensing tip.
3. Take the solder paste cartridge and unscrew the lower end cap. Screw the dispensing tip on the outlet opening of the solder paste cartridge.
4. Insert the solder paste cartridge into the dispense adapter and tighten the upper fastening nut carefully.

Fig. 65: Installed dispense set

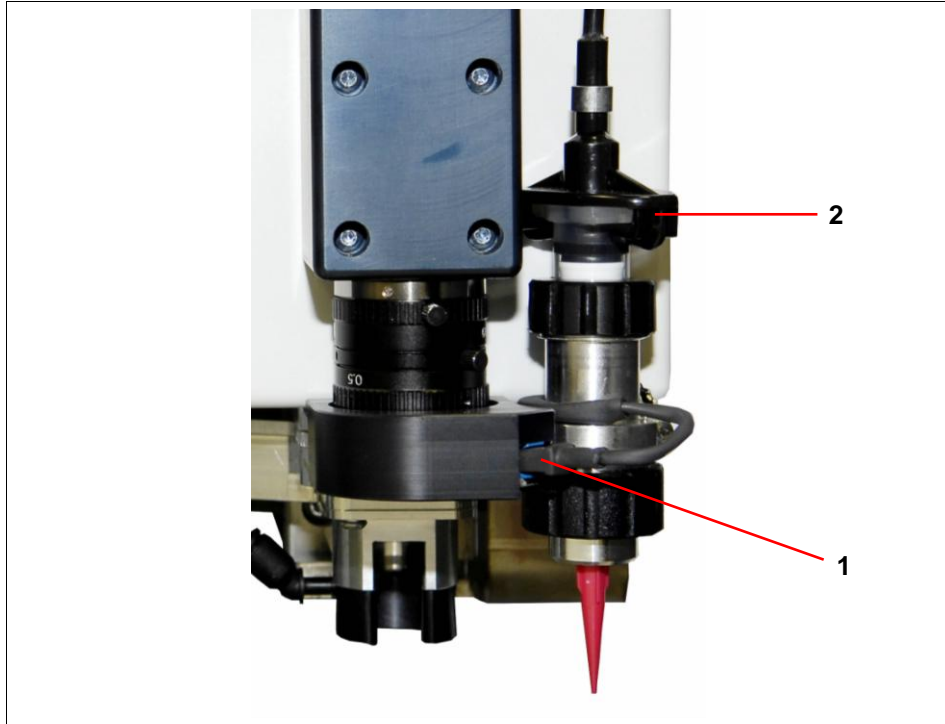

5. Remove the upper closure cap of the solder paste cartridge and plug in the coupling of the plastic hose /2/. Turn the coupling to fix it on the solder paste cartridge.
6. Loosen the lower fastening nut and plug the dispense adapter into the fixing device on the right side of the mill/drill head.
7. Plug the dispense adapter connection cable into the jack on the camera lighting system /1/.

◆ The dispense device is ready to operate.

6.9.2 Dispense process



Note

A production file with the prepared solder paste layer must be created before the dispense process can start.

■ Dispense process

1. Click on File>Open to open the project file.
 - ➔ The project file will be loaded and the project data is displayed in the window “CAM view”.
2. Click on Toolpath>Dispense.
 - ➔ The following window is shown:

Fig. 66: Window Dispense

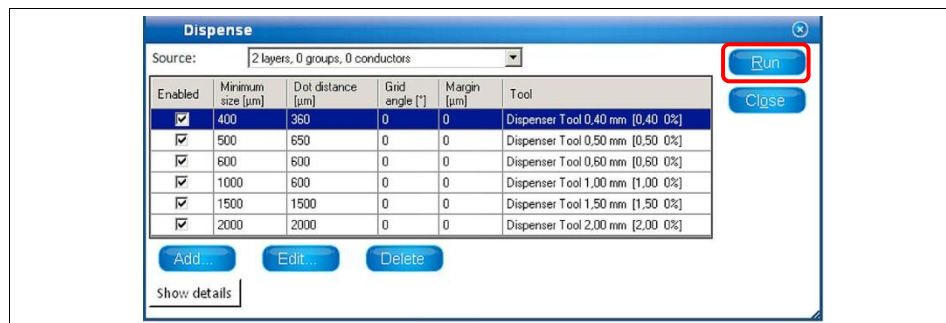

3. Use the default values or enter new dispense parameters for the current project.
4. Click [Run].
 - ➔ The program is assigning the solder paste points.
5. Click on Wizards>Dispense preparation wizard.
 - ➔ The wizard is starting and the following window is shown:

Fig. 67: Start Dispense preparation wizard

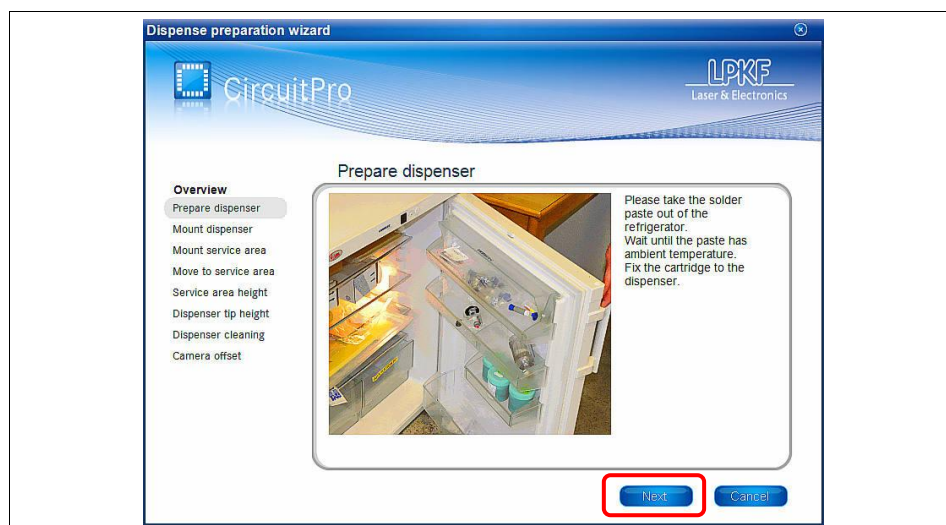

6. Follow the instructions and click [Next].

➔ After all processing steps have been carried out the following window is shown:

Fig. 68: Dispense preparation wizard finished

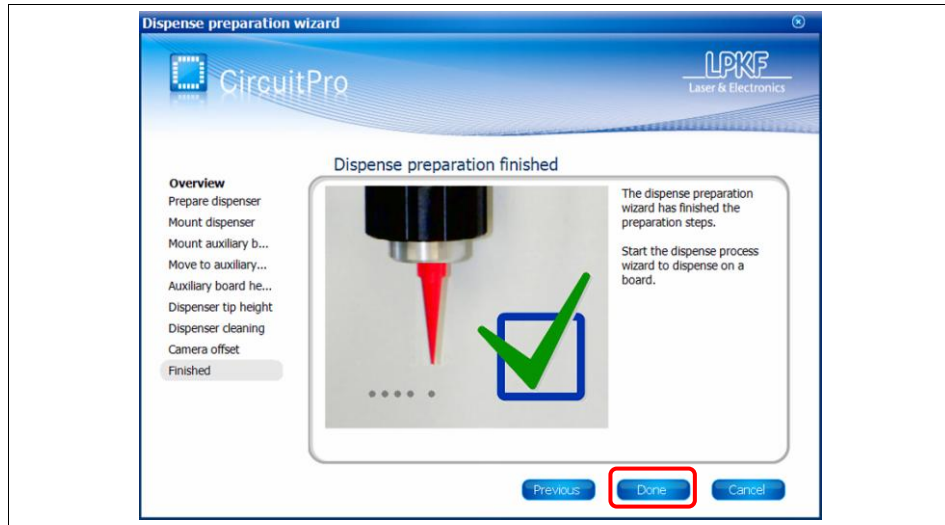

7. Click [Done].

➔ The dispense preparation is finished.

8. Click on Wizards>Dispensing wizard.

➔ The wizard is starting and the following window is shown:

Fig. 69: Start Dispensing wizard

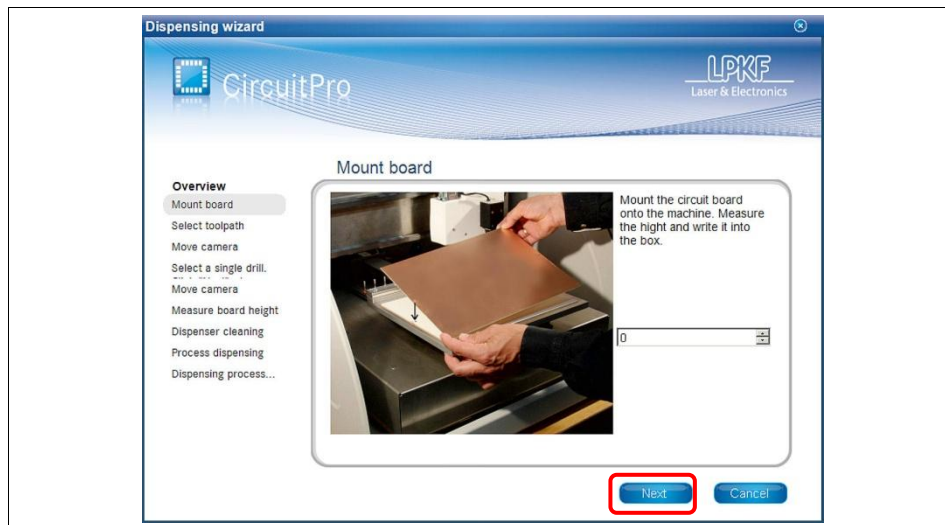

9. Follow the instructions and click [Next].

➔ After all processing steps have been carried out the following window is shown:

Fig. 70:
Dispensing wizard
finished

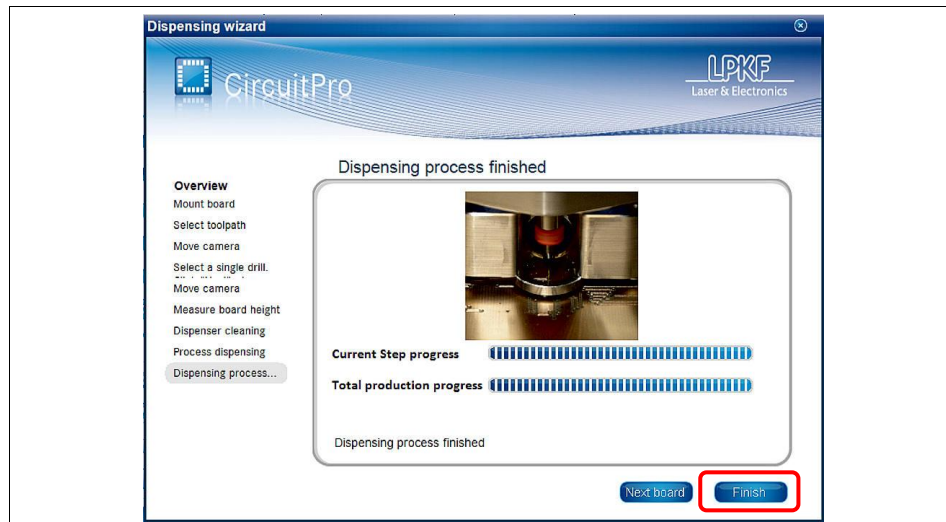

10. Click [Finish].

◆ The dispensing process is finished.

6.10 Shutdown the System

Always proceed in the same sequence when shutdown the system:

- I Save the current CBF file
- II Exit **CircuitPro**
- III Switch off the circuit board plotter
- IV Shutdown and switch off the PC
- V Switch off the dust extraction

6.10.1 Saving the CBF file



Always save the current production data.

Note

It is possible to save the current production data under the same file name or under a new file name as well.

■ Saving the CBF file



All existing data will be overwritten!

Note

1. Click File>Save.

◆ The production data was saved by using the current file name.

■ Saving a new CBF file

1. Click File>Save as....

➔ The window "Save as..." is shown:

Fig. 71: Save as...

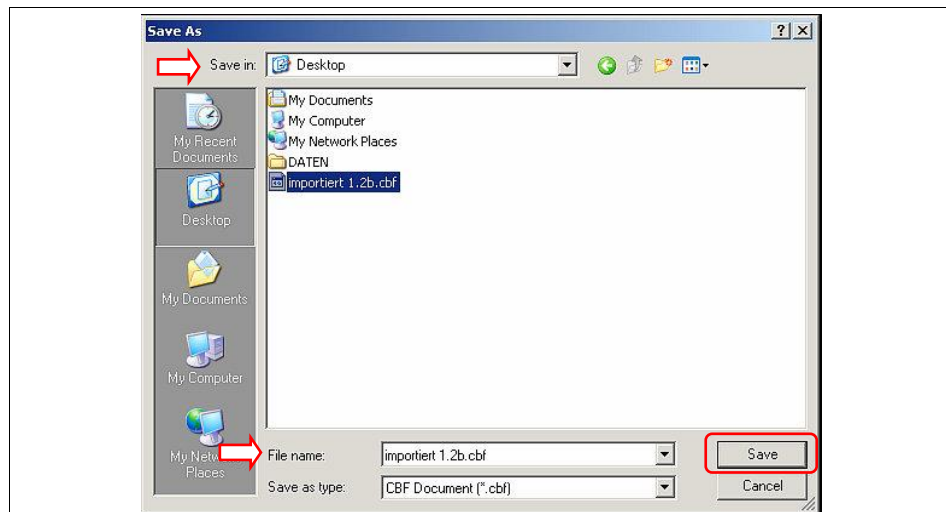

2. Click the input field \Save in\ and select the destination folder.
3. Click the input field \File name\ and edit the new file name.
4. Click [Save].

◆ The production data is saved in a new file.

6.10.2 Exit CircuitPro

When exit **CircuitPro** the mill/drill head and the working table are moving to the zero position.

■ Exit **CircuitPro**

1. Click File>Exit.

◆ **CircuitPro** is terminated.

6.10.3 Switch off the circuit board plotter



Note

Always wait until the mill/drill head and the working table have reached their reference position.

■ Switch off the circuit board plotter

1. Open the soundproof hood.
2. Set the main switch of the circuit board plotter to position **0 (OFF)**.
3. Close the soundproof hood.

◆ The circuit board plotter is switched off.

6.10.3.1 Shutdown and switch off the PC



Note

Of course the PC can be left in action whenever the PC is used for other applications.

■ Shutdown the PC

1. Click Start>Shut down.
2. Wait until the PC is completely shut down and set the main switch of the PC in position **OFF (0)**.

◆ The PC is switched off.

6.10.4 Switch off the dust extraction



Note

The dust extraction has only to be switched off if the system operates in continuous running mode.

In automatic mode the dust extraction is switched on/off via the circuit board plotter.

■ Switch off the dust extraction

1. Turn the main switch of the dust extraction to position **OFF (0)**.

◆ The dust extraction is switched off.

7 Trouble shooting

This chapter gives some information concerning correction of small faults that may occur during operation of the circuit board plotter.



Note

Please contact the LPKF service if the measures described in this chapter do not provide the desired success. LPKF is **not** liable for improper repairs!

Tab. 14: Trouble shooting

Fault	Cause	Remedy
No connection	No power supply	Check the mains cable and insert the mains plug into the socket if necessary. Click Machining>Connect and the window "Connect the machine" opens. Click [Connect].
	Main switch of the circuit board plotter is in position OFF	Set the switch to position ON . Click Machining>Connect and the window "Connect the machine" opens. Click [Connect].
	No data transmission	Check the USB cable between plotter and PC. Fix the connector plug or exchange the USB cable. Click Machining>Connect and the window "Connect the machine" opens. Click [Connect].
		Check the USB settings of the operating system. Click Machining>Connect and the window "Connect the machine" opens. Click [Connect].
No dust extraction	No power supply	Check the mains cable and insert the mains plug into the socket if necessary.
	Main switch of the dust extraction is in position OFF	Set the operation mode switch to either ON or AUTOMATIK .
	Fuse triggered	Press the Reset Button of the dust extraction.
	No data transmission	Check the USB cable between circuit board plotter and dust extraction. Fix the connector plug or exchange the cable.
Tool uptight	Position of the tool holder is incorrect	Import the tool holder position again.
	Tool was not correctly inserted into the tool holder	Insert the tool with its top down into the tool holder until it stops.
	Tool holder soiled	Clean the tool holder.
	Collet chuck soiled	Clean the collet chuck.

8 Maintenance/servicing

This chapter lists the most important maintenance and servicing activities.

8.1 Regular maintenance

Regular maintenance of the circuit board plotter includes a visual inspection before any start of operation and regular careful cleaning.

■ Visual inspection

1. Check the mains cable of the circuit board plotter, the USB cable to the PC, the connection cable and the tube to the dust extraction.
- ➔ Replace damaged cables or tubes at once.
2. Check the soundproof hood for visible damages.
3. Open the hood and check the mill/drill head and the working table for visible damages.
- ➔ Contact the LPKF service immediately whenever you find a damaged part and make sure that the circuit board plotter is not used until the damaged part is removed.

◆ The visual inspection is successfully terminated and the circuit board plotter can be set to operation.

■ Cleaning the circuit board plotter



Clean the circuit board plotter with a dry and antistatic cloth and a paintbrush. To remove heavy soiling use a slightly damp cloth.

Note

1. Disconnect the circuit board plotter from the mains power supply.
2. Clean the soundproof hood using a dry and antistatic cloth.
3. Open the hood and clean the working table with a paintbrush and slightly damp cloth.
4. Close the hood after cleaning.
5. Connect the circuit board plotter to the mains power supply.

◆ Now the circuit board plotter is cleaned.

8.2 Maintenance

For proper function of the circuit board plotter maintenance activities have to be carried out in certain intervals.



ATTENTION

Risk of injury by unintended operations!

Any accidental starting of the motor and moving of the mill/drill head during repairs or maintenance may cause severe injuries.

Make sure that only one person operates the machine. Secure the machine during servicing and repair activities appropriate.



ATTENTION

Risk of injury by sudden cover closing!

The opened soundproof cover may close accidentally and jam finger or the complete hand.

Always lift the soundproof cover up to the latching position and secure the machine against any shocks.

Tab. 15:
Maintenance and
service plan

Component	Interval/Control	Maintenance activity
Milling depth limiter	After 100 operating hours	cleaning
Chucks	After 100 operating hours	cleaning
Tool position	Tool is not correctly inserted	Configure tool position
Dust extraction	Extraction power decreases perceptible	Exchange fine particle filter

9 Storage

This chapter describes the storage of the circuit board plotter.

9.1 Shutdown

Before the machine can be stored set the circuit board plotter out of operation.

■ Disassembly of the circuit board plotter

1. Switch off the circuit board plotter and the dust extraction.
2. Unplug the mains cable from the electrical safety socket.
3. Remove the tube from the dust extraction.
4. Remove the connection cable from the dust extraction.
5. Remove the USB cable from the PC.
6. Open the hood and remove the mains cable.
7. Install the transport locks.
8. Place all the connection cables on the working table and close the hood.

◆ Now the circuit board plotter is disassembled.



Note

The PC and the dust extraction have to be disassembled accordingly. The systems can be used for other machines or they can be stored as well. The appropriate information concerning disassembly and storage can be found in the respective operation manuals.

9.2 Storage



Note

The circuit board plotter has to be stored in the covering box in a cool and dry location.



ATTENTION

Risk of injury due to heavy load!

The machine is heavy and bulky and cannot be transported or lifted by one person!

Lift and transport the machine always with two persons.

■ Packaging the circuit board plotter

1. Place the covering box besides the work desk.
2. Open the box cover and take the unpacking instruction.
3. Follow the unpacking instruction step by step in reverse direction.

◆ Now the circuit board plotter is packed.

■ Storing the circuit board plotter

1. Select an adequate location (cool and dry) for storage.
2. Place the covering box on an euro pallet.
3. Transport the euro pallet with a lift truck to the storage location.
4. Protect the covering box with a foil or a suitable tarpaulin.

◆ Now the circuit board plotter is stored.

9.2.1 Disposal



Note

Legal regulations and directives concerning disposal of electric devices and machines have to be observed.

Dispose of the circuit board plotter must be done according to legal directives.

10 Appendix

10.1 Tools and consumables

10.1.1 Tools

Any tool for the circuit board plotter can be ordered individually:

Tab. 16: Tools

Tool specification	Length (mm)	Ø (mm)	Order code
End Mill RF, special tool, cylindrical, 1/8"	36	0,15	115 832
End Mill RF, special tool, cylindrical, 1/8"	36	0,25	115 833
End Mill RF, special tool, cylindrical, 1/8"	36	0,40	115 834
Universal Cutter, conical, 1/8"	36	0,2/0,5	115 835
Micro Cutter, Fine Line, conical, 1/8"	36	0,1/0,15	115 836
End Mill long, cylindrical, PCB/aluminium 1/8"	38	1,00	115 837
End Mill long, cylindrical, PCB/aluminium 1/8"	38	2,00	129 102
End Mill, cylindrical, PCB/aluminium, 1/8"	36	0,80	115 839
End Mill, cylindrical, PCB/aluminium, 1/8"	36	1,00	115 840
End Mill, cylindrical, PCB/aluminium, 1/8"	36	2,00	129 100
End Mill, cylindrical, PCB/aluminium, 1/8"	36	3,00	129 101
Contour Router, special tool, cylindrical, 1/8"	38	1,00	115 844
Contour Router, special tool, cylindrical, 1/8"	38	2,00	129 099
Spiral Drill, cylindrical, 1/8"	38	0,20	115 846
Spiral Drill, cylindrical, 1/8"	38	0,30	115 847
Spiral Drill, cylindrical, 1/8"	38	0,40	115 848
Spiral Drill, cylindrical, 1/8"	38	0,50	115 849
Spiral Drill, cylindrical, 1/8"	38	0,60	115 850
Spiral Drill, cylindrical, 1/8"	38	0,70	115 851
Spiral Drill, cylindrical, 1/8"	38	0,80	115 852
Spiral Drill, cylindrical, 1/8"	38	0,85	115 853
Spiral Drill, cylindrical, 1/8"	38	0,90	115 854
Spiral Drill, cylindrical, 1/8"	38	1,00	115 855
Spiral Drill, cylindrical, 1/8"	38	1,10	115 856
Spiral Drill, cylindrical, 1/8"	38	1,20	115 857
Spiral Drill, cylindrical h, 1/8"	38	1,30	115 858
Spiral Drill, cylindrical, 1/8"	38	1,40	115 859

Tab. 16: Tools

Tool specification	Length (mm)	Ø (mm)	Order code
Spiral Drill, cylindrical, 1/8"	38	1,50	115 860
Spiral Drill, cylindrical, 1/8"	38	1,60	115 861
Spiral Drill, cylindrical, 1/8"	38	1,70	115 862
Spiral Drill, cylindrical, 1/8"	38	1,80	115 863
Spiral Drill, cylindrical, 1/8"	38	1,90	115 864
Spiral Drill, cylindrical, 1/8"	38	2,00	115 865
Spiral Drill, cylindrical, 1/8"	38	2,10	115 866
Spiral Drill, cylindrical, 1/8"	38	2,20	115 867
Spiral Drill, cylindrical, 1/8"	38	2,30	115 868
Spiral Drill, cylindrical, 1/8"	38	2,40	115 869
Spiral Drill, cylindrical, 1/8"	38	2,95	115 870
Spiral Drill, cylindrical, 1/8"	38	3,00	115 871

Furthermore LPKF offers tool sets.

10.1.1.1 Tool set 1/8"

Order code: 129 103

Tab. 17: Tool set 1/8"

Tool specification	Length (mm)	Ø (mm)	Quantity
End Mill, cylindrical, PCB/Aluminium, 1/8"	36	1,00	2
End Mill, cylindrical, PCB/Aluminium, 1/8"	36	2,00	1
Contour Router, special tool, cylindrical, 1/8"	38	1,00	1
Contour Router, special tool, cylindrical, 1/8"	38	2,00	1
Spiral Drill, cylindrical, 1/8"	38	0,60	5
Spiral Drill, cylindrical, 1/8"	38	0,70	5
Spiral Drill, cylindrical, 1/8"	38	0,80	5
Spiral Drill, cylindrical, 1/8"	38	1,00	5
Spiral Drill, cylindrical, 1/8"	38	1,10	2
Spiral Drill, cylindrical, 1/8"	38	1,20	2
Spiral Drill, cylindrical, 1/8"	38	1,50	2
Spiral Drill, cylindrical, 1/8"	38	3,00	2

10.1.1.2 HF and micro wave tool set 1/8"

Order code: 116 394

Tab. 18: HF-Tool set 1/8"

Tool specification	Length (mm)	Ø (mm)	Quantity
End Mill RF, special tool, cylindrical, 1/8"	36	0,15	3
End Mill RF, special tool, cylindrical, 1/8"	36	0,25	5
End Mill RF, special tool, cylindrical, 1/8"	36	0,40	3
End Mill long, cylindrical, PCB/aluminium 1/8"	38	2,00	2
End Mill, cylindrical, PCB/aluminium, 1/8"	36	1,00	5
End Mill, cylindrical, PCB/aluminium, 1/8"	36	2,00	2

10.1.2 Consumables

10.1.2.1 Base material

Tab. 19: Base material

Material	Dimensions (mm)	Copper (µm)	Quantity	Order code
Base material FR4	420 x 297 x 1,5	18/18	10	106 398
Base material FR4	420 x 297 x 1,5	-/35	10	106 400
Base material FR4	420 x 297 x 1,5	35/35	10	106 401
Base material FR4 with protective foil	420 x 297 x 1,5	5/5	10	112 059
Base material FR4 reference holes 3 mm	229 x 305 x 1,5	18/18	10	115 967
Base material FR4 reference holes 3 mm	229 x 305 x 1,5	-/18	10	115 968
Base material FR4 reference holes 3 mm	229 x 305 x 1,5	-/35	10	115 969
Base material FR4 reference holes 3 mm	229 x 305 x 1,5	35/35	10	115 970
Base material FR4 reference holes 3 mm and protective foil	229 x 305 x 1,5	5/5	10	115 971

10.1.2.2 Multilayer material

Tab. 20:
Multilayer
material

Material	Dimensions (mm)	Copper (µm)	Quantity	Order code
Thin laminate 104 ML with protective foil for galvanic	229 x 305 x 0,2	-/5	1	119 571
Prepeg Type 2125	275 x 200 x 0,1	/	2	119 572
Base material FR4	229 x 305 x 1,0	18/18	1	119 574
Base material 104 ML	229 x 305 x 0,36	18/18	1	119 575
Thin laminate 104 ML without protective foil for ProConduct	229 x 305 x 0,2	-/18	1	119 818
Pressing plate with reference holes	229 x 205 x 1,6	/	1	120 345
Press cushion with reference holes	229 x 305 x 1,7	/	1	120 999

10.1.2.3 Dispense material

Tab. 21: Dispense
material

Material	Quantity	Order code
Dispense needle	1	129 130
SolderPaste with cartridge	1	129 096

10.2 Glossary

B	Base copper	Copper foil single or double sided fixed on the insulating substrates for PCB.
	Base material	The isolated material applied with the copper circuit structures (conductor tracks and annular rings). The base material can be either inflexible or flexible (bendable).
D	Dielectric	A dielectric is an electrically nonconductive, insulating material.
	Dispense	A dispenser applies tiny amounts of the solder paste kept in a cartridge on a printed circuit board.. The application of SMD adhesive and other materials, which can be filled into cartridges is called dispensing, too.
F	Fiducial	Optical labelling on the surface of the printed circuit board for correct arrangement. It is designates as OS as well.
L	Lamination	A cathode-quality electrolytic copper deposition as a thin, continuous sheet on rotating drums direct from refinery electrolytes. Used as a conductor for printed circuits, copper foil readily bonds to insulating substrates, accepts the printed resists, and etches out to make printed circuits.
M	Multilayer	A product consisting of alternate layers of conductive patterns and insulating materials bonded together, with conductive patterns in mote than two layers, and with the conductive patterns interconnected as required.
P	Prepreg	Prepregs are epoxy impregnated and pre-polymerised glass cloth laminates for the construction of multilayer PCB. Due to the good flow behaviour all clearances are filled up free from air thus producing a perfect interpass fusion and adhesion of the prepreg layers as well as the copper foils.
R	Resist	Coating material used to mask or to protect selected areas of a pattern from the action of an etchant solder, or plating
	Rubout area	Defined copper-free areas on the multilayer PCB will be labelled as rubout area. Only the conductor tracks and the annular rings are included.
S	Soldering stop mask	Coatings which mask off and surface insulate those areas of a circuit where soldering is not desired.
T	Throughplating	An electrical connection between conductive patterns on opposite sides of an insulating base, e.g. plated-through hole or clinched jumper wire.

10.3 List of figures

Fig. 1: ProtoMat S Series.....	9
Fig. 2: Position type label.....	10
Fig. 3: Typen label information	10
Fig. 4: Front view	27
Fig. 5: Rear view.....	28
Fig. 6: Interfaces	28
Fig. 7: Right side.....	29
Fig. 8: Left side	29
Fig. 9: Worktable ProtoMat S43	30
Fig. 10: Worktable ProtoMat S43	31
Fig. 11: Worktable ProtoMat S43	32
Fig. 12: Tool magazine	32
Fig. 13: Mill/drill head PotoMat S43.....	33
Fig. 14: Tool holder ProtoMat S43.....	33
Fig. 15: Mill/drill head ProtoMat S63/S103	34
Fig. 16: Tool holder unit.....	35
Fig. 17: Camera	35
Fig. 18: Required space.....	45
Fig. 19: Transport lock	47
Fig. 20: Connections.....	48
Fig. 21: Start-up Logo	50
Fig. 22: Dummy tool.....	51
Fig. 23: Startup image	54
Fig. 24: Check active tool	55
Fig. 25: User interface	56
Fig. 26: Menu bar.....	57
Fig. 27: Function bar.....	58
Fig. 28: Window Processing	59
Fig. 29: Control of mill/drill head	60
Fig. 30: Select head.....	61
Fig. 31: Operate.....	62
Fig. 32: Move to Position	63
Fig. 33: Head movement	64
Fig. 34: Select circuit board plotter	65
Fig. 35: Connect	65
Fig. 36: Connection.....	66
Fig. 37: User interface	66
Fig. 38: Control	67
Fig. 39: Control	68
Fig. 40: Tool change	69
Fig. 41: Tool settings	69
Fig. 42: Machining view	70
Fig. 43: Insert tool.....	70
Fig. 44: Tool exchange	71

Fig. 45: Tool setup	71
Fig. 46: Tool holder	72
Fig. 47: Machining view select tool	74
Fig. 48: Adjust position	74
Fig. 49: Control milling/drilling head	74
Fig. 50: Mill/drill head	78
Fig. 51: Optimal milling depth	78
Fig. 52: Machining view select tool	79
Fig. 53: Set position	79
Fig. 54: Milling/drilling head control	79
Fig. 55: Start wizard	82
Fig. 56: Process planning wizard	82
Fig. 57: Summary	83
Fig. 58: Window Open	84
Fig. 59: Working area	84
Fig. 60: Start wizard	85
Fig. 61: Process planning wizard	85
Fig. 62: Process planning wizard	86
Fig. 63: Complete dispense set	87
Fig. 64: Dispense adapter	88
Fig. 65: Installed dispense set	89
Fig. 66: Window Dispense	90
Fig. 67: Start Dispense preparation wizard	90
Fig. 68: Dispense preparation wizard finished	91
Fig. 69: Start Dispensing wizard	91
Fig. 70: Dispensing wizard finished	92
Fig. 71: Save as...	93

10.4 List of tables

Tab. 1: Scope of delivery	11
Tab. 2: Accessories	11
Tab. 3: PC data.....	12
Tab. 2: Data of dust extraction	12
Tab. 4: Machining materials	26
Tab. 5: LED signalling ProtoMat S43	33
Tab. 2: LED signalling ProtoMat S63/ S103.....	34
Tab. 6: Technical data ProtoMat S43	38
Tab. 7: Technical data ProtoMat S63	39
Tab. 8: Technical data ProtoMat S103.....	40
Tab. 9: User interface	56
Tab. 10: Menus.....	57
Tab. 11: Function bars.....	58
Tab. 12: Tool colour coding	72
Tab. 13: Tool position display code	72
Tab. 14: Trouble shooting.....	95
Tab. 15: Maintenance and service plan.....	98
Tab. 16: Tools.....	101
Tab. 17: Tool set 1/8".....	102
Tab. 18: HF-Tool set 1/8".....	103
Tab. 19: Base material.....	103
Tab. 20: Multilayer material	104
Tab. 21: Dispense material.....	104

10.5 Index

- ABS copolymere 36
- AC power socket 48
- accessorie 11
- accessories** 23
- accident prevention** 23
- aluminium 36
- automatical mode 54
- automatical operation 53
- Base copper 105
- base material 25, 26, 36, 57
- Base material 26, 105
- Base material 104 ML 104
- Base material FR4 11, 103, 104
- Betriebsspannung 10
- brass 36
- camera 9
- Camera 34, 35
- cartridge 87
- CBF file 81, 84, 93
- circuit board 26, 36, 41
- circuit board plotter 9, 25, 26, 27, 33, 34, 36, 37, 38, 39, 40, 41, 43, 45, 46, 48, 49, 50, 53, 55, 56, 59, 65, 66, 69, 70, 73, 76, 78, 81, 93, 94, 95, 97, 98, 99, 100
- circuit board plotters 43
- CircuitPro 9, 11, 21, 36, 46, 50, 53, 54, 84, 93, 94
- cleaning 97
- Cleaning pad 26
- Collection efficiency 12
- collet chuck 22, 33, 73, 76, 81, 95
- Collet chuck 95
- connection cable 97, 99
- Connector 32
- consumable 26
- Control PC 62
- cover 50
- Cover knob 27
- covering box 43, 46, 100
- CPU 12
- depth of penetration 76
- Dielectric 105
- Dispense 105
- dispense adapter 88, 89
- Dispense adapter 87
- dispense device 87, 89
- dispense parameter 90
- dispense preparation 91
- dispense process 90, 92
- Dispense process 90
- dispense set 87, 88
- dispenser 35
- dispensing tip 88
- Dispensing tip 87
- Dispose 100
- distance ring 72
- down time 43
- Drill underlay 11
- drilling spindle 80
- dust extraction 11, 21, 36, 41, 45, 46, 47, 48, 49, 50, 53, 54, 80, 81, 93, 94, 95, 98, 99
- ear protection 41
- Ear protection 41
- environmental protection representative 41
- Exhaust power 12
- exhaust unit 64
- export work file 57
- extraction power 50
- Fiducial 105
- fiducials 9, 11
- fine particle 21, 41, 73, 81
- fine particle filter 21, 36, 41, 73, 76, 81, 98
- fine particles 76
- Fixing tape 11
- foam mat 43
- Fräsbohrplotter 53
- function bar 56
- fuse 21
- Fuse 11
- fuse protection 21
- gas 21
- Hard disk 12
- head illumination 9
- HF tool set 11
- home-position 63
- humidity 43
- import work file 57
- installation 37, 45, 46

- interface 48
- labour protection regulation** 23
- labour protection regulations** 23
- Lamination 105
- lift truck 46, 100
- LPKF port 28
- LPKF service** 23, 36, 37, 97
- LPKF-Service 95
- machine 21, 23, 45
- machine Interfaces 28
- machining phase 62
- machining process 56, 62
- machining remains** 23
- main switch 54
- mains cable 47, 48, 97, 99
- mains power supply** 23, 37
- maintenance 37
- maintenance set 11
- manual drilling 53
- manual milling 53
- manufacturer 14, 16, 18
- Manufacturer 13
- maschine 43, 46, 100
- material dust 41
- measuring microscope 76, 78
- Measuring microscope 11
- menu bar 56
- mill/drill head 21, 30, 31, 32, 43, 59, 60, 63, 64, 67, 68, 73, 74, 75, 76, 80, 94, 97, 98
- milling depth 76
- Milling depth adjustment 33
- Milling depth limiter 98
- milling tool 76
- milling track 11, 76
- Monitor 12
- motor 73
- Motor 64
- motor speed 9
- moving speed 9
- Multi layer 81
- multilayer 25, 26, 36
- Multilayer 26, 105
- noise level 41
- Objective 35
- operating hours 98
- operation 37
- operation mode switch 50
- pause position 63, 67, 68
- PC 45, 46, 47, 48, 50, 93, 94
- PCB 81
- PCB material 74, 79
- permanent acoustic noise level 41
- polyoxymethylen 36
- Power cable 11
- power supply 95
- Prepreg 105
- printed circuit board 25
- processing material 41
- production data 82
- production material 67, 68
- production phase 53
- production process 83
- Produktionsjahr 10
- project 84
- project file 90
- protective clothing** 23, 41
- protective glove 73, 81
- protective gloves 76
- ProtoMat S 11
- RAM 12
- reference hole 67, 68
- reference hole drill 11
- reference hole pivot 11, 67, 68
- reference hole pivots 11
- reference hole stripe 11
- reference position 63
- repair** 23
- Resist 105
- resolution 9
- Respirator mask 41
- rest material 41
- ring light 35
- RS232 cable 48
- Rubout area 105
- safety glasses 41
- safety gloves 22, 41
- safety zone 45
- scope of delivery 11
- Screen resolution 12
- Seriennummer 10
- Service 13
- Sinter plate 26
- SMD 87
- socket 21

- solder paste 87, 88, 105
- solder paste cartridge 88, 89
- solder paste layer 90
- solder paste point 90
- solder resist mask 25, 36
- soldering paste stencil 25
- soldering paste stencils 36
- Soldering stop mask 105
- sound proof housing 11
- soundproof cover 22, 27
- soundproof hood 41, 48, 54, 67, 68, 94, 97
- soundproof housing 54
- Soundproof housing 27
- start of operation 46, 97
- start up procedure 45
- start up the machine** 23
- Status LED 33, 34
- status light 9
- StatusLight 11
- Staubabsaugung 94
- Steuerungsrechner 53
- tape 67
- Technical data ProtoMat S103 40
- Technical data ProtoMat S43 38
- Technical data ProtoMat S63 39
- technical information 37
- technical modifications 37
- Throughplating 105
- tool 22, 23, 35, 71, 72, 73, 76, 81
- tool change 73, 76, 81
- tool exchange 9
- tool exchange appliance 69
- tool holder 35, 95
- Tool holder 33, 34, 95
- tool magazine 70
- tool path 57
- tool position 72
- tool position display 72
- tool set 11
- toolbox 73, 77, 81
- transport lock 47, 99
- transport protection band 43
- tube 48, 49, 97, 99
- tube coupler 49
- Typ 10
- underlay 26, 67, 68
- unpacking instruction 46
- USB cable 11, 48, 95, 97, 99
- USB port 28, 29
- user interface 66
- vacuum table 9, 11, 26
- vibration values 41
- visual check** 23
- waste of material 41
- window Machining 56
- Wizard 90, 91
- work area 57
- work clothes** 23
- work desk 46, 100
- work file 57
- work piece 21, 45
- work protection measure 41
- work space** 23
- working area 56, 57, 84
- working desk 43
- working table 26, 67, 68, 74, 78, 79, 94, 97, 99
- Working table 30, 31, 32
- zero position 94

